

**OPERATING,  
MAINTENANCE  
& PARTS  
MANUAL**

---

**ELECTRIC  
CHAIN HOIST**

For more information contact:  
American Crane & Equipment Corp.  
Authorized Distributor  
Tel: 877-503-2972  
Fax: 484-945-0430  
sales@americancrane.com  
www.americancrane.com



# **XL ELECTRIC CHAIN HOIST**

Before installing hoist, fill in the information below. Refer to the hoist identification plate.

Model No. \_\_\_\_\_

Serial No. \_\_\_\_\_

Purchase Date \_\_\_\_\_

Voltage \_\_\_\_\_

Rated Capacity \_\_\_\_\_

Rated capacities 2 through 7½ tons/  
2000 through 7500 kg

**Follow all instructions and warnings for inspecting, maintaining and operating this hoist.**

The use of any hoist presents some risk of personal injury or property damage. That risk is greatly increased if proper instructions and warnings are not followed. Before using this hoist, each operator should become thoroughly familiar with all warnings, instructions and recommendations in this manual.

**Retain this manual for future reference and use.**

Forward this manual to operator.  
Failure to operate equipment as directed in manual may cause injury.

## XL HOIST PARTS AND SERVICES ARE AVAILABLE IN THE UNITED STATES AND IN CANADA

As a XL Hoist user, you are assured of reliable repair and parts services through a network of Master Parts Depots and Service Centers that are strategically located in the United States and Canada. These facilities have been selected on the basis of their demonstrated ability to handle all parts and repair requirements promptly and efficiently.

Below is a list of the Master Parts Depots in the United States and Canada. To quickly obtain the name of the U.S. Service Center located nearest you, call (800) 888-0985. Fax: (716) 689-5644. In the following list, the Canadian Service Centers are indicated.

UNITED STATES MASTER PARTS DEPOT	CANADIAN SERVICE CENTERS
<b>ARKANSAS</b> YALE HOISTS P.O. Box 1000 3105 North Washington Forest City Ar 72335 800/999-6318 Fax 800/766-0223	<b>ALBERTA</b> **COLUMBUS McKINNON, LTD. 10311-174th Street Edmonton, Alberta T8H 1N3
<b>CALIFORNIA</b> OTTO SYSTEMS, INC. 12010 Bloomfield Ave. Santa Fe Springs, CA 90670 562/462-1612 or 800/596-7392 Fax 562/462-1617 or 2439 Verna Court San Leandro, CA 94577 510/667-3730 or 800/508-6886 Fax 510/667-3726	NOVA SCOTIA *W & A MOIR 95 Ilsley Ave. Dartmouth, Nova Scotia B3B 1L5 902/468-7720 Fax 902/468-3777
<b>COLORADO</b> MATERIALS HANDLING EQUIPMENT CO. 1740 W. 13th Ave. Denver, CO 80204 303/573-5333 or 800/873-5333 Fax 303/893-3854	<b>ONTARIO</b> *R & W HOIST REPAIR, LTD. 790 Redwood Square Units 5, 6, & 7 Oakville, Ontario L6L 6N3 905/825-5500 Fax 905/825-5315
<b>GEORGIA</b> ACE INDUSTRIES, INC. 6295 McDonough Drive Norcross, GA 30093 770/441-0898 or 800/733-2231 Fax 770/441-0326	*TORONTO ELECTRIC HOIST SALES & SERVICE 72 Crockford Blvd. Scarborough, Ontario M1R 3C4 416/755-7716 Fax 800/461-0290
<b>ILLINOIS</b> CM CHICAGO PARTS & SERVICE 7747 West Van Buren Street Forest Park, IL 60130 877/511-3170 Fax 708/771-7326	*MASLACK SUPPLY, LTD. 488 Falconbridge Road Sudbury, Ontario P3A 4S4 705/566-1270 Fax 705/566-4208
<b>INDIANA</b> HORNER ELECTRIC COMPANY, INC. 1521 East Washington Street Indianapolis, IN 46201 317/639-4261 Fax 317/639-4344	*COLUMBUS McKINNON, LTD. P.O. Box 1106 10 Brook Road, North Cobourg, Ontario K9A 4W5 905/372-0153 Fax 905/372-3078
<b>IOWA</b> Tec-Industrial 1958 West River Drive Davenport, IA 52808 319/323-3233 Fax 319/336-5161	<b>QUEBEC</b> *HERCULES SLING & CABLE 2525 Louis A. Amos Lachine, Quebec H8T 1C3 514/631-5511 Fax 514/636-1084
<b>LOUISIANA</b> BEERMAN PRECISION, INC. 4206 Howard Ave. New Orleans, LA 70125 504/486-9391 Fax 504/486-7482	*LEGER HOIST EQUIPMENT CO. 7995-17th Ave. Montreal, Quebec H1Z 3R2 514/376-3050 Fax 514/376-0657
<b>MASSACHUSETTS</b> ABEL DISTRIBUTORS, INC. 50 Parker Street, Unit 2 Newburyport, MA 01950 978/463-0700 Fax 978/463-5200	*ARE ALSO MASTER PARTS DEPOTS **MASTER PARTS DEPOT ONLY
<b>MICHIGAN</b> GAYLORD HOIST SALES & SERVICE 34471 Industrial Road Livonia, MI 48150 734/261-1910 Fax 734/261-1788	<b>MICHIGAN</b> LIFT-TECH INTERNATIONAL P.O. Box 769 414 West Broadway Avenue Muskegon, MI 49443-0769 800/742-9269 or 800/742-9270
<b>MISSOURI</b> INDEPENDENT ELECTRIC MACHINERY 4425 Oliver Street Kansas City, MO 66106 913/362-1155 Fax 913/904-3330	<b>NEW YORK</b> VOLLAND ELECTRIC EQUIPMENT CO. 75 Innsbruck Drive Buffalo, NY 14227 716/656-9900 Fax 716/656-8898/8899
<b>NORTH CAROLINA</b> SOUTHERN ELECTRIC SERVICE CO., INC. 2225 Freedom Drive Charlotte, NC 28208 704/372-4832 or 800/487-3726 Fax 704/342-2604	<b>OHIO</b> MAZZELLA LIFTING TECHNOLOGIES 21000 Aerospace Parkway Cleveland, OH 44142 440/239-5700 or 800/362-4601 Fax 440/239-5707
<b>PENNSYLVANIA</b> AMICK ASSOCIATES, INC. 11 Sycamore Street Carnegie, PA 15106-0529 412/429-1212 or 800/445-9456 Fax 412/429-0191	<b>TEXAS</b> ABEL EQUIPMENT CO., INC. 3710 Cavalier Drive Garland, TX 75042 972/272-7706 Fax 972/272-6955
<b>RAM MOTORS &amp; CONTROLS, INC.</b> 5460-B Pottsville Pike Leesport, PA 19533 610/916-8000 or 877/916-8018 Fax 610/916-7957	<b>HYDRAULIC EQUIPMENT SERVICES, INC.</b> 1021 North San Jacinto Street Houston, TX 77002 713/228-9601 Fax 713/228-0931
<b>TEXAS</b> ABEL EQUIPMENT CO., INC. 3710 Cavalier Drive Garland, TX 75042 972/272-7706 Fax 972/272-6955	<b>WISCONSIN</b> TRESTER HOIST & EQUIPMENT, INC. W136 N4863 Campbell Drive Menomonee Falls, WI 53051 262/790-0700 or 800/234-6098 Fax 262/790-1009

# SAFETY PRECAUTIONS

Each XL Electric Hoist is built in accordance with the specifications contained herein and at the time of manufacture complied with our interpretation of applicable sections of the \*American Society of Mechanical Engineers Standard B30.16 "Overhead Hoists," the National Electrical Code (ANSI/NFPA 70) and the Occupational Safety and Health Act. Since OSHA states the National Electrical Code applies to all electric hoists, installers are required to provide current overload protection and grounding on the branch circuit section in keeping with the code. Check each installation for compliance with the application, operation and maintenance sections of these articles.

The safety laws for elevators, lifting of people and for dumbwaiters specify construction details that are not incorporated in XL hoists. For such applications, refer to the requirements of applicable state and local codes, and the American National Safety Code for elevators, dumbwaiters, escalators and moving walks (ASME A17.1). Columbus McKinnon Corporation cannot be responsible for applications other than those for which CM equipment is intended.

\* Copies of this Standard can be obtained from ASME Order Department, 22 Law Drive, Box 2300, Fairfield, NJ 07007-2300, U.S.A.

<div style="text-align: center; font-weight: bold; margin: 5px 0;"> <p><b>THIS SYMBOL POINTS OUT IMPORTANT SAFETY INSTRUCTIONS WHICH IF NOT FOLLOWED COULD ENDANGER THE PERSONAL SAFETY AND/OR PROPERTY OF YOURSELF AND OTHERS. READ AND FOLLOW ALL INSTRUCTIONS IN THIS MANUAL AND ANY PROVIDED WITH THE EQUIPMENT BEFORE ATTEMPTING TO OPERATE YOUR XL HOIST.</b></p> </div>
--

<div style="text-align: center; font-weight: bold; margin: 5px 0;"> <p><b>WARNING</b></p> </div>
<p>Usage of hoists that do not involve lifting of the load on the lower hook or using hoists in the inverted position without special precaution may cause an accident resulting in injury and/or property damage.</p>
<p><b>TO AVOID INJURY:</b></p>
<p>Consult Factory for information concerning using hoists in these applications.</p>

<div style="text-align: center; font-weight: bold; margin: 5px 0;"> <p><b>WARNING</b></p> </div>
<p>Improper operation of a hoist can create a potentially hazardous situation which, if not avoided, could result in <u>death</u> or <u>serious injury</u>. To avoid such a potentially hazardous situation, the operator shall:</p>

1. **Not** operate a damaged, malfunctioning or unusually performing hoist.
2. **Not** operate the hoist until you have thoroughly read and understood this Operating, Maintenance and Parts Manual.
3. **Not** operate a hoist which has been modified.
4. **Not** lift more than the rated load for the hoist.
5. **Not** use hoist with twisted, kinked, damaged or worn load chain.
6. **Not** use the hoist to lift, support, or transport people.
7. **Not** lift loads over people.
8. **Not** operate a hoist unless all persons are and remain clear of the supported load.
9. **Not** operate unless load is centered under hoist.
10. **Not** attempt to lengthen the load chain or repair damaged load chain.
11. Protect the hoist's load chain from weld splatter or other damaging contaminants.
12. **Not** operate hoist when it is restricted from forming a straight line from hook to hook in the direction of loading.
13. **Not** use load chain as a sling, or wrap load or chain around load.
14. **Not** apply the load to the tip of the hook or to the hook latch.
15. **Not** apply load unless load chain is properly seated in the chain wheel(s) or sprocket(s).
16. **Not** apply load if bearing prevents equal loading on all load chains.
17. **Not** operate beyond the limits of the load chain travel.
18. **Not** leave load supported by the hoist unattended unless specific precautions have been taken.

19. **Not** allow the load chain or hook to be used as an electrical or welding ground.
20. **Not** allow the load chain or hook to be touched by a live welding electrode.
21. **Not** remove or obscure the warnings on the hoist.
22. **Not** operate a hoist on which the safety placards or decals are missing or illegible.
23. **Not** operate a hoist unless it has been securely attached to a suitable support.
24. **Not** operate a hoist unless load slings or other approved single attachments are properly sized and seated in the hook saddle.
25. Take up slack carefully - make sure load is balanced and load holding action is secure before continuing.
26. Shut down a hoist that malfunctions or performs unusually and report such malfunction.
27. Make sure hoist limit switches function properly.
28. Warn personnel of an approaching load.

<div style="text-align: center; font-weight: bold; margin: 5px 0;"> <p><b>CAUTION</b></p> </div>
<p>Improper operation of a hoist can create a potentially hazardous situation which, if not avoided, could result in <u>minor</u> or <u>moderate</u> injury. To avoid such a potentially hazardous situation, the operator shall:</p>

1. Maintain a firm footing or be otherwise secured when operating the hoist.
2. Check brake function by tensioning the hoist prior to each lift operation.
3. Use hook latches. Latches are to retain slings, chains, etc. under slack conditions only.
4. Make sure the hook latches are closed and not supporting any parts of the load.
5. Make sure the load is free to move and will clear all obstructions.
6. Avoid swinging the load or hook.
7. Make sure hook travel is in the same direction as shown on the controls.
8. Inspect the hoist regularly, replace damaged or worn parts, and keep appropriate records of maintenance.
9. Use the hoist manufacturer's recommended parts when repairing the unit.
10. Lubricate load chain per instructions in this manual.
11. **Not** use the hoist load limiting or warning device to measure load.
12. **Not** use limit switches as routine operating stops unless allowed by manufacturer. They are emergency devices only.
13. **Not** allow your attention to be diverted when operating hoist.
14. **Not** allow the hoist to be subjected to sharp contact with other hoists, structures, or objects through misuse.
15. **Not** adjust or repair the hoist unless qualified to perform such adjustments or repairs.

# Hoist safety is up to you...

**WARNING** — DO NOT LIFT MORE THAN RATED LOAD.

## 1 CHOOSE THE RIGHT HOIST FOR THE JOB ...

Choose a hoist with the capacity for the job. Know the capacities of your hoists and the weight of your loads. Then match them.

The application, the size and type of load, the attachments to be used and the period of use must also be taken into consideration in selecting the right hoist for the job.



Remember the hoist was designed to ease our burden and carelessness not only endangers the operator, but in many cases, a valuable load.

**WARNING** — DO NOT OPERATE DAMAGED OR MALFUNCTIONING HOIST  
— DO NOT OPERATE WITH TWISTED, KINKED OR DAMAGED CHAIN.

## 2 INSPECT

All hoists should be visually inspected before use, in addition to regular, periodic maintenance inspections.

Inspect hoists for operations warning notices and legibility.

Deficiencies should be noted and brought to the attention of supervisors. Be sure defective hoists are tagged and taken out of service until repairs are made.



Under no circumstances should you operate a malfunctioning hoist.

Check chain for gouged, twisted, distorted links and foreign material. Do not operate hoists with twisted, kinked or damaged links.

Load chain should be properly lubricated.

Hooks that are bent, worn or whose openings are enlarged beyond normal throat opening should not be used. If latch does not engage throat opening of hook, hoist should be taken out of service.

Check for misphasing—hook travel should correspond to control direction.

Carefully check limit switches without a load. Care should be taken not to damage the hoist.



**WARNING** — DO NOT PULL AT AN ANGLE. BE SURE HOIST AND LOAD ARE IN A STRAIGHT LINE.  
— DO NOT USE LOAD CHAIN AS A SLING.

## 3 USE HOIST PROPERLY



Be sure hoist is solidly held in the uppermost part of the support hook arc.



Be sure hoist and load are in a straight line. Do not pull at an angle.



Be sure load is hooked securely. Do not tip load the hook. Do not load hook latch. Hook latch is to prevent detachment of load under slack chain conditions only.



Do not use load chain as a sling. Such usage damages the chain and makes the limit switch setting ineffective.



Do not operate with hoist head resting against any object. Lift the load gently. Do not jerk it.

**WARNING** — DO NOT LIFT PEOPLE OR LOADS OVER PEOPLE.

## 4

Do not lift co-workers with a hoist.

Make sure everyone is clear of the load when you lift.

Do not remove or obscure operational warning notices.



## 5

### CLEANING

Hoists should be kept clean and free of dust, dirt, moisture, etc., which will in any way affect the operation or safety of the equipment.

### LUBRICATION

Chain should be properly lubricated.

### AFTER REPAIRS

Carefully operate the hoist before returning it to full service.



**VIOLATION OF ANY OF THE WARNINGS LISTED MAY RESULT IN SERIOUS PERSONAL INJURY TO THE OPERATOR OR NEARBY PERSONNEL BY RELEASED LOAD OR BROKEN HOIST COMPONENTS.**

# FOREWORD

This manual contains important information to help you properly install, operate and maintain your hoist for maximum performance, economy and safety.

Please study its contents thoroughly before putting your hoist into operation. By practicing correct operating procedures and by carrying out the recommended preventative maintenance suggestions, you will experience long, dependable and safe service. After you have completely familiarized yourself with the contents of this manual, we recommend that you carefully file it for future reference.

The information herein is directed to the proper use, care and maintenance of the hoist and does not comprise a handbook on the broad subject of rigging. Rigging can be defined as the process of lifting or moving heavy loads using hoist and other mechanical equipment. Skill acquired through specialized experience and study is essential to safe rigging operations. For rigging information, we recommend consulting a standard textbook on the subject.

## TABLE OF CONTENTS

ITEM	PAGE NO.	ITEM	PAGE NO.
<b>MASTER PARTS DEPOTS AND SERVICE CENTERS</b> . . . . .	i	<b>MAINTENANCE</b>	
<b>SAFETY PRECAUTIONS</b> . . . . .	ii	<b>INSPECTIONS</b> . . . . .	12
<b>HOIST SAFETY IS UP TO YOU</b> . . . . .	iii	FREQUENT INSPECTIONS . . . . .	12
<b>GENERAL INFORMATION</b>		PERIODIC INSPECTIONS . . . . .	12
<b>SPECIFICATIONS</b> . . . . .	2	HOOK INSPECTION . . . . .	12
<b>REPAIR/REPLACEMENT POLICY</b> . . . . .	3	LOAD CHAIN . . . . .	13
<b>ACCESSORIES</b> . . . . .	3	PROTECTOR . . . . .	13
<b>INSTALLATION</b>		<b>LUBRICATION</b>	
<b>UNPACKING</b> . . . . .	4	HOIST . . . . .	15
<b>INSTALLING THE SUSPENSION</b>		TROLLEY . . . . .	15
HOOK SUSPENSIONS . . . . .	4	<b>ADJUSTMENTS</b>	
LUG SUSPENSIONS . . . . .	6	HOIST BRAKE . . . . .	15
<b>MOUNTING TROLLEY ON HOIST</b> . . . . .	6	LIMIT SWITCHES . . . . .	16
<b>INSTALLING TROLLEY SUSPENDED</b>		TROLLEY BRAKE . . . . .	17
<b>HOIST ON BEAM</b> . . . . .	7	<b>RECOMMENDED SPARE PARTS</b> . . . . .	18
<b>INSTALLING BREATHER</b> . . . . .	8	<b>PREVENTIVE MAINTENANCE</b> . . . . .	18
<b>POWER SUPPLY SYSTEM</b> . . . . .	8	<b>TROUBLE SHOOTING</b>	
<b>ELECTRICAL CONNECTIONS</b>		ALL HOISTS . . . . .	19
SINGLE SPEED DUAL VOLTAGE		TWO SPEED HOISTS . . . . .	22
HOISTS (AND MOTOR DRIVEN TROLLEYS) . . . . .	9	MOTOR DRIVEN TROLLEY . . . . .	23
ALL HOISTS . . . . .	9	<b>ELECTRICAL DATA</b> . . . . .	24, 25
CHECKING FOR TWIST IN LOAD CHAIN . . . . .	10	<b>WIRING DIAGRAMS</b> . . . . .	26, 28
CHECKING FOR ADEQUATE VOLTAGE . . . . .	10	<b>DISASSEMBLY</b> . . . . .	29
<b>CHECKING LIMIT SWITCH OPERATION</b> . . . . .	10	<b>REASSEMBLY</b> . . . . .	29
<b>CHAIN CONTAINER</b> . . . . .	10	<b>REMOVAL AND REPLACEMENT OF LOAD CHAIN</b> . . . . .	29
<b>CONTROL CORD</b> . . . . .	10	<b>REEVING LOAD CHAIN</b>	
<b>OPERATING INSTRUCTIONS</b>		3,4 AND 5 TON DOUBLE REEVED UNITS . . . . .	30
<b>GENERAL</b> . . . . .	11	5,6 AND 7 1/2 TON TRIPLE REEVED UNITS . . . . .	31
<b>ALL HOISTS</b> . . . . .	11	<b>CUTTING CHAINS</b> . . . . .	31
<b>HOIST WITH PLAIN TROLLEY</b> . . . . .	11	<b>TESTING</b> . . . . .	32
<b>HOIST WITH GEARED TROLLEY</b> . . . . .	11	<b>REPAIR PARTS</b>	
<b>HOIST WITH MOTOR DRIVEN TROLLEY</b> . . . . .	11	<b>ORDERING INSTRUCTIONS</b> . . . . .	32
<b>SAFETY PROCEDURES</b> . . . . .	11	<b>EXPLODED VIEWS AND PARTS LISTS</b> . . . . .	33-47

# GENERAL INFORMATION

## SPECIFICATIONS

The XL Electric Chain Hoist is a highly versatile material handling device that can be used to lift loads that are within its rated load capacity. Single and Two speed units with rated loads up to 7½ tons (7500 kg.) are available. The hoist can be supplied with a single hook suspension up to 6 ton (6000 kg.) capacity or suspended from a plain, geared or motor driven trolley. The standard lift is 10 feet and longer lifts can be provided on a per order basis.

The standard features of the XL Electric Chain Hoist include:

- Hardened, alloy steel, oblique lay liftwheel provides constant chain speed and reduces chain wear.
- Hoistaloy® load chain for long and dependable service.
- Lightweight cast aluminum frame and covers.
- Surface hardened, alloy steel, helical gears running in an oil bath provide smooth and quiet operation.
- Protector that prevents lifting an excessive overload.
- Single or two speed hoist duty motor equipped with thermal protection.
- Low voltage control circuit. 115 volt is standard. 24 or 48 volt control circuits are also available.
- Hardened, forged steel hooks equipped with latch.

- Oversize reversing and speed selecting contactors for long, trouble free service.
- Hoist duty, A.C. motor brake plus regenerative braking.
- Weatherproof, CM snap action 2 or 4 direction control station.
- Shielded, lifetime lubricated ball bearings at all rotating points. Open bearings are used in gear case.
- Voltage conversion board on single speed, dual voltage units.
- Three stage gear reduction.
- Upper and lower screw type limit switches.



**XL Hoist with Motor Driven Trolley**

**TABLE 1—SPECIFICATIONS  
LODESTAR XL ELECTRIC CHAIN HOISTS**

RATED LOAD	TONS Kg.	2 2000			3 3000	4 4000	5 5000	5 5000	6 6000			7½ 7500		
		*LIFTING SPEEDS AVAILABLE: SINGLE SPEEDS	FPM	18	24	30	9	12	15.2	6	8	6	8	10
	MPM	5.5	7.3	9.1	2.7	3.6	4.6	1.8	2.4	1.8	2.4	3.0	1.8	3.0
TWO SPEEDS	FPM	6 / 18	8 / 24	N/A	3/9	4/12	N/A	2/6	2.7/8	2/6	2.7/8	N/A	2/6	N/A
	MPM	1.8 / 5.5	2.4 / 7.3	N/A	.9/2.7	1.2 / 3.6	N/A	.6/1.8	.8/2.4	.6/1.8	.8/2.4	N/A	.6/1.8	N/A
MAXIMUM LIFT	FEET	127	139	71	60	65	106	42	46	42	46	71	42	71
	METERS	39	42	22	19	21	32	13	14	13	14	22	13	22
REEVING OF LOAD CHAIN		SINGLE			DOUBLE			TRIPLE						
MINIMUM HEADROOM HOOK SUSPENDED—IN. (mm)		25 (635)			35.31 (897)			36.18 (919)						N/A
TROLLEY SUSPENDED—IN. (mm)		28.69 (729)			33 (841)	33.38 (848)	34.25 (870)	34.25 (870)						
RANGE OF TROLLEY ADJUSTABILITY "S" BEAMS		6 X 12.5' TO 15 X 42.9'			8 X 18.4' TO 20 X 66.0'									
FLANGE WIDTH	IN.	3.33 TO 5.50			4.00 TO 6.250									
	mm	84.5 TO 139.7			101.6 TO 158.8									
STANDARD MOTOR DRIVEN TROLLEY TRAVEL SPEED—FPM (MPM)		65 (19.8) OR 100 (30.4)			50 (15.2)									
**APPROX. NET WEIGHT—LBS. (Kg.)														
HOOK SUSPENDED		368 (167)			442 (200)		442 (200)	474 (215)						
WITH PLAIN TROLLEY		428 (194)			497 (225)		597 (271)	629 (285)						
WITH GEARED TROLLEY		473 (215)			512 (232)		607 (275)	639 (290)						
WITH MOTOR DRIVEN TROLLEY		483 (219)			582 (264)		632 (287)	664 (301)						

\*Lifting speeds are based on 60 Hertz power supply. When operating on 50 Hertz, lifting speeds will be 5/6 of those listed.  
\*\*Weights are for single speed hoist with 10 ft. (3 M) lift. For two speed hoists, add 10 pounds (4.5 Kg.).

## REPAIR/REPLACEMENT POLICY

All XL Electric Chain Hoists are thoroughly inspected and performance tested prior to shipment. If any properly maintained hoist develops a performance problem due to a material or workmanship defect, as verified by factory, repair or replacement of the unit will be made to the original purchaser without charge. This repair/replacement policy applies only to XL Hoists installed, maintained and operated as outlined in this manual, and specifically excludes parts subject to normal wear, abuse, improper installation, improper or inadequate maintenance, hostile environmental effects and unauthorized repairs/modifications.

We reserve the right to change materials or design if, in our opinion, such changes will improve our product. Abuse, repair by an unauthorized person, or use of non-factory replacement parts voids the guarantee and could lead to dangerous operation. For full Terms of Sale, see Sales Order Acknowledgement. Also, refer to the back cover for Limitations of Warranties, Remedies and Damages, and Indemnification and Safe Operation.

## ACCESSORIES

### HOOK SUSPENSIONS

Hook suspensions are available for suspending 2 through 6 ton hoist from a trolley with a single load bar or for suspending the hoist from a fixed structure.



**HOOK SUSPENSION**

### LUG SUSPENSIONS

Lug suspensions are required to suspend the XL Electric Hoist from plain, geared or motor driven trolleys described below. When the hoist is to be suspended from a plain, geared or motor driven trolley, the lug suspension is attached to the hoist prior to shipment.



**LUG SUSPENSION**

## PLAIN TROLLEYS

These are manual push type trolleys designed for use with the XL Electric Hoist. The trolley is adjustable to operate on a range of American Standard 'S' beams and flat flanged beams. The plain trolley is mounted on hoist prior to shipment.



**PLAIN TROLLEY**

## GEARED TROLLEYS

The geared trolley is similar to the plain trolley except it is moved by the means of a hand chain. The hand chain rotates a pinion that drives gears attached to trolley wheels and moves trolley along the beam. The geared trolley is mounted on the hoist prior to shipment.



**GEARED TROLLEY**

## MOTOR DRIVEN TROLLEYS

The motor driven trolley is similar to geared trolley except the hand chain wheel is replaced with a gear reducer and an electric motor. The motor is energized by a reversing contactor mounted inside the hoist and it is controlled by push buttons located in the pendant control station. A variety of single and two speed trolley travel speeds are available and the motor driven trolley is mounted on hoist prior to shipment.

# INSTALLATION



**MOTOR DRIVEN TROLLEY**

## CHAIN CONTAINER

This accessory is used to hold the slack chain and it is supplied complete with mounting hardware and instructions. The chain container is recommended for those applications where the slack chain will interfere with the load or drag on the floor as may be the case with double and triple reeved units. Chain containers are shipped separately and can be furnished for units already in use.



## LATCHLOK® HOOKS

Latchlok hooks are available to replace the standard upper or lower latch type hooks (2-6 ton only). The unique design of the Latchlok hook assures that it will stay locked until the operator releases it by depressing the release button. It will not open accidentally—even if the load chain goes slack. Once opened, it can be shut with one hand or the weight of the load when it is lifted. Latchlok hooks can be supplied with the hoist or it can be provided in kit form for hoists already in service.

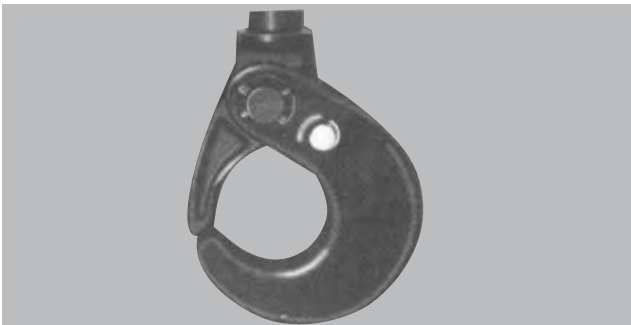

**LATCHLOK® HOOK**

## UNPACKING

After opening the carton, carefully inspect the hoist, suspension, trolley and chain container for damage that may have occurred during shipment. If there is damage, refer to the packing slip envelope.

## INSPECT FOR SHIPPING DAMAGE

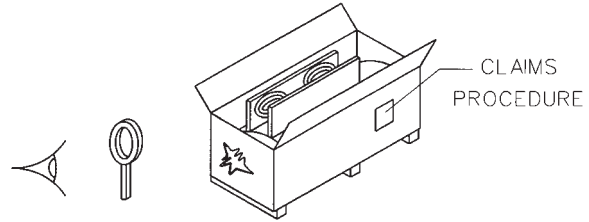

## ⚠ WARNING

Operating a unit with obvious external damage may cause load to drop and that may result in personal injury and/or property damage.

## TO AVOID INJURY:

Carefully check unit for external damage prior to installation.

Make sure that the power supply to which the hoist is to be connected is the same as that shown on the identification plate located on the bottom of the hoist. For single speed, dual voltage hoists, refer to instructions on page 8.

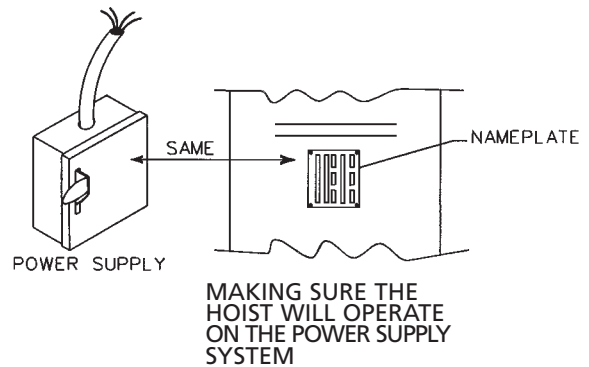

## INSTALLING SUSPENSION

### A. HOOK SUSPENSIONS

For hook suspended 2 through 6 ton units, the suspension is shipped separately and it must be attached to the hoist as follows:

1. 2 THROUGH 6 TON. Supplied with the hook suspension is a counterweight that must be attached to the motor cover using the two long screws provided. Remove and discard corresponding motor cover screws. Place counterweight on motor cover and secure it using the two longer screws. Tighten these screws to a seating torque of 16 pound feet (22 NM).



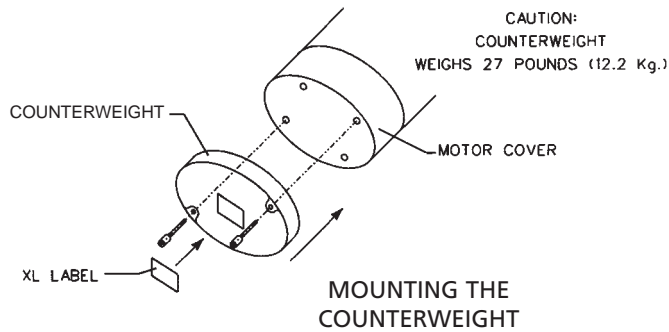

Attach the "XL" label, from the kit, to counterweight in the recess provided for same.

**2. 2 Ton Single Reeved Units.** As shipped from the factory, the hook is rigid with the plane of the hook parallel to the long axis of the hoist. The hook can be changed to swivel type or the plane of the hook can be changed to perpendicular to the long axis of the hoist as follows:

- If a swivel type hook is required, use a 1/4 inch (6.4 mm) drift, and working through the hole in the side of the suspension adapter, drive the hook nut pin into the nut so that it is flush with the side of the nut. Discard the loose pin packed with the suspension.

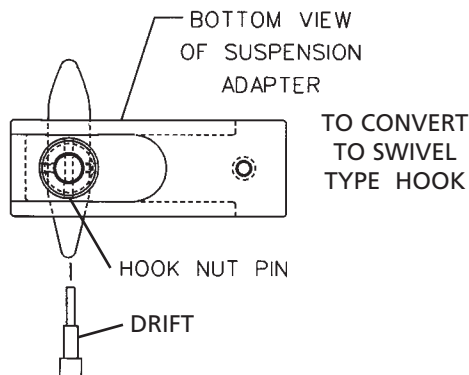

- If it is necessary to position the hook so that the plane of the hook is perpendicular to the long axis of hoist, first convert to a swivel type hook as described above. Rotate the hook 90 degrees and slide the loose pin (packed with the suspension) through the hole in the side of the suspension adapter and engage the hole in the hook nut.

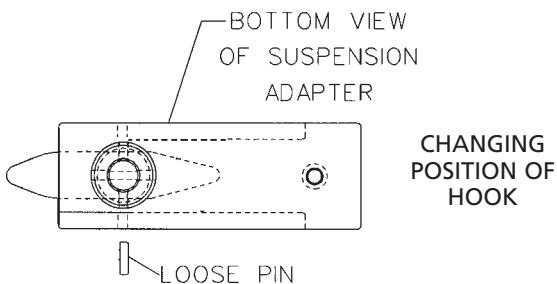

- After the hook is in the desired position, slide the suspension adapter into cavity on top of hoist and secure it using the suspension adapter screw from the kit. Tighten screw to a seating torque of 16 pound feet (22 NM).

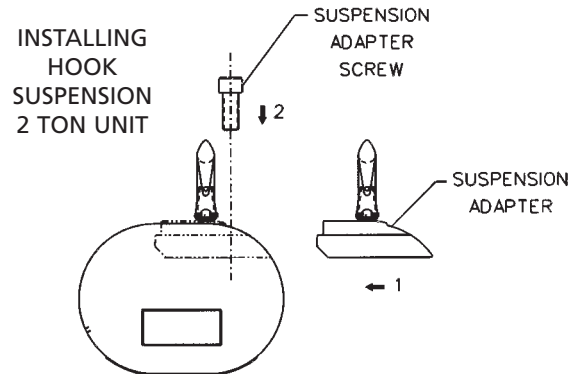

**NOTE: INSTALL BREATHER IN MAIN HOUSING AFTER HOOK SUSPENSION IS ASSEMBLED TO HOIST. SEE PAGE 8.**

**3. 3, 4 and 5 Ton Double Reeved and 5 and 6 Ton Triple Reeved Units.** As shipped from the factory, the hook is rigid with the plane of the hook parallel to long axis of hoist. The hook can be changed to swivel type or the plane of the hook can be changed to perpendicular to the long axis of the hoist as follows:

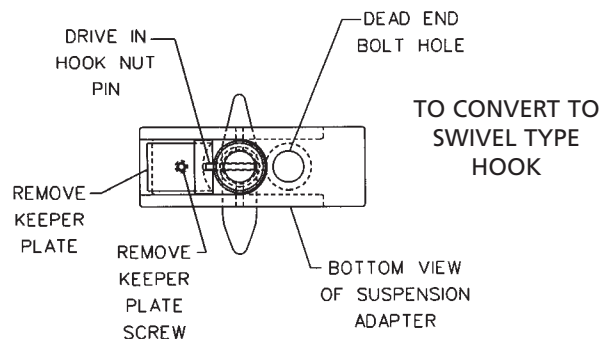

- If a swivel type hook is required, remove and discard keeper plate screw and keeper plate. Then using a hammer, drive the hook nut pin into nut so that the end of the pin is flush with side of the nut.
- If it is necessary to position the hook so that the plane of the hook is perpendicular to long axis of hoist, first convert to a swivel type hook as described above but do not discard the keeper plate and screw. Turn hook 90 degrees and insert loose pin (packed with the suspension) into a hole in the hook nut. Loosely reassemble keeper plate to suspension adapter so that the hook is free to swivel approximately 45 degrees in either direction. The hook will be made rigid after suspension is attached to the hoist.

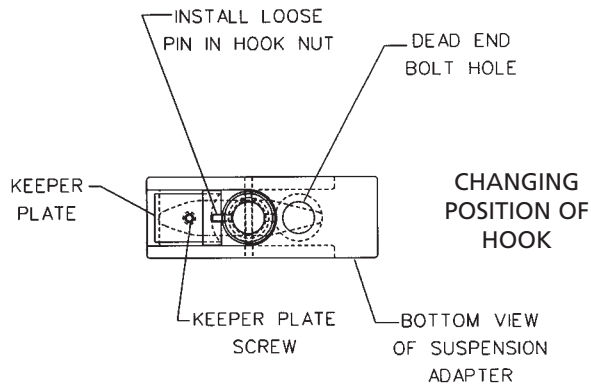

c. Slide the suspension adapter into cavity on top of hoist. Install dead end bolt and thread it by hand to engage the dead end block (3, 4 and 5 ton double reeved units) or idler sheave hanger (5 and 6 ton units). Then tighten dead end bolt to a seating torque of 120 pound feet (160NM).

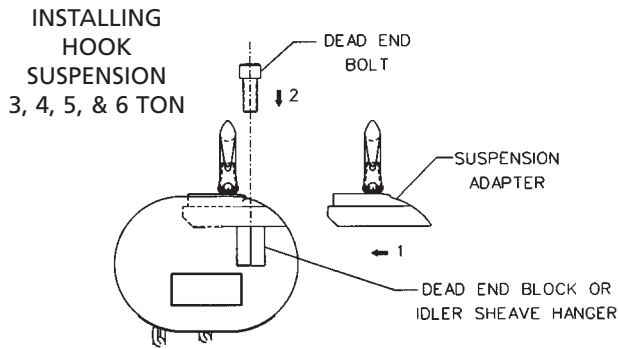

If the hook is to be perpendicular to long axis of hoist per step b above, rotate the hook to that position and firmly tighten the keeper plate screw while making sure the loose pin engages the slot in keeper plate.

**NOTE: INSTALL BREATHER IN MAIN HOUSING AFTER HOOK SUSPENSION IS ASSEMBLED TO HOIST. SEE PAGE 8.**

**B. LUG SUSPENSIONS**

The following instructions are provided to cover installing the lug suspension after the hoist has been reassembled following inspection and/or repair. On hoists shipped from factory, the lug suspension is installed prior to mounting the trolley.

1. **2 Ton Single Reeved Units.** Slide the suspension adapter into the cavity on top of hoist and secure it using the suspension adapter screw. Tighten the screw to a seating torque of 16 pound feet (22 NM).

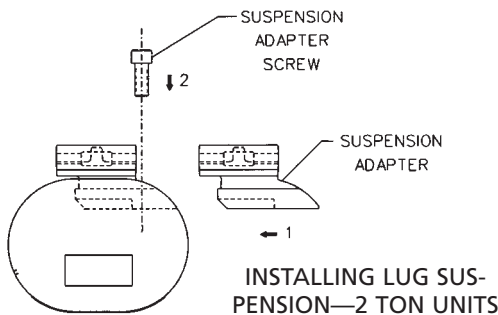

2. **3, 4 And 5 Ton Double Reeved And 5, 6 And 7½ Ton Triple Reeved Units.** Slide the suspension adapter into cavity on top of hoist. Install dead end bolt and thread it by hand to engage the dead end block (3, 4 and 5 ton double reeved units) or idler sheave hanger (5, 6 and 7 1/2 ton triple reeved units). Then tighten the dead end bolt to a seating torque of 120 pound feet (160 NM).

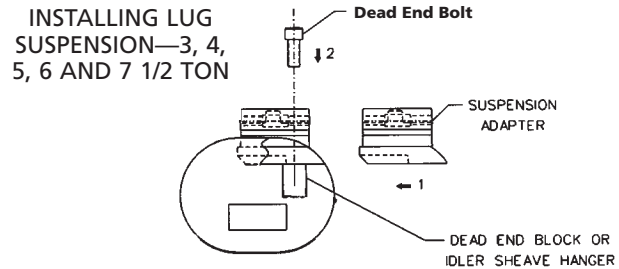

**⚠ WARNING**

Using other than factory supplied suspension adapter screw or dead end bolt to attach suspension adapter to hoist may cause the screw or bolt to break and allow the hoist and load to fall.

**TO AVOID INJURY:**

Use only the factory supplied suspension adapter screw or dead end bolt and tighten these to the seating torque specified above.

**MOUNTING TROLLEY ON HOIST**

The following instructions are provided to cover mounting plain, geared and motor driven trolleys after the hoist has been reassembled following inspection and/or repair. On units shipped from factory, these trolleys are mounted on the hoists.

1. Measure actual width of the beam flange on which the trolley is to operate. To determine proper trolley side frame spacing to assure that adequate wheel clearance is provided, the distance between the beam flange and the inside face of the trackwheel flange (approximately 1/8 to 3/16 inch on straight runway beams, 3/16 to 1/4 inch on curved beams for 2 ton units. See Figure 2) and (1/4 inch for straight runway beams, 3/8 inch on curved beams for 3-7 1/2 ton units. See Figure 1).
2. Use Table 2 to determine proper spacing for 2 ton units. On 3-7 1/2 ton capacity units, proper spacing is obtained by varying the number of spacer washers (furnished with trolley) that are installed on the suspension pins.

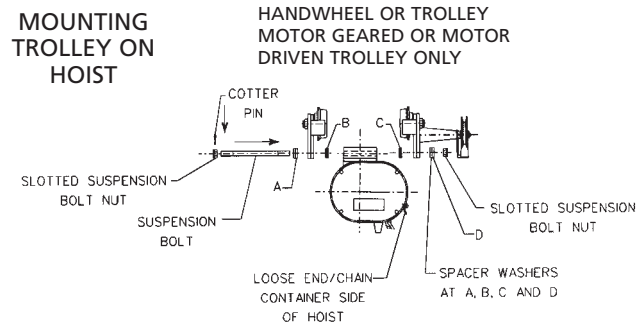

- For 2 ton units, assemble a slotted nut to one end of each suspension bolt and secure it using a cotter pin. Spread legs of cotter pin to keep it in place. Using Table 2 as a reference for washer spacing, assemble side frames and bolts and washers together as shown below. Do not install remaining cotter pins at this time. These are to be installed after the trolley is mounted on the beam.

For 3-7½ ton units, temporarily assemble trolley to hoist using 3 or 4 washers at each end of suspension pins, between side plates and suspension lug. Tighten pin nuts for accurate check of spacing. Measure the distance between the inside faces of the trackwheel flanges and compare to the dimension required. Remove trolley side plates and add or remove an equal number of inside spacer washers as required to obtain proper distance between wheels. When spacing is correct, install all remaining spacer washers on the outside ends of each suspension pin and secure the pins with lockwashers and hex nut (See Note Below). The nuts should not be completely tightened until after hoist and trolley are mounted onto beam.

**NOTE: It is very important that all spacer washers that come with the trolley be used. Install remaining spacer washers equally on outside ends of each suspension pin.**

- On geared and motor driven trolleys, make sure the handwheel or motor is on side opposite the loose end/chain container side of the hoist.

### INSTALLING TROLLEY SUSPENDED HOIST ON BEAM

 <b>WARNING</b>
Operating the trolley on a beam that has no rail stops may allow the trolley to fall off the end of the beam.
<b>TO AVOID INJURY:</b>
Install rail stops at each end of the beam on which the trolley is to operate.

Stops must be positioned to contact the trolley side frames and not exert impact force on the hoist.

Trolleys are mounted on the hoist prior to shipment and side frames are positioned for the nominal beam flange specified on the order. However, due to variations in beam flange widths, actual beam flange width should be measured to determine the exact distribution of the spacer washers. See Mounting Trolley On Hoist Section.

 <b>WARNING</b>
If washer spacing recommendations are not followed, trolley may fall from beam.
<b>TO AVOID INJURY:</b>
Measure the actual beam flange on which the trolley is to operate and use Table 2 to determine the arrangement of the spacer washers for that flange width.

**NOTE: USE OF OTHER THAN SUPPLIED SPACER WASHERS MAY CAUSE IMPROPER TRACKWHEEL SPACING.**

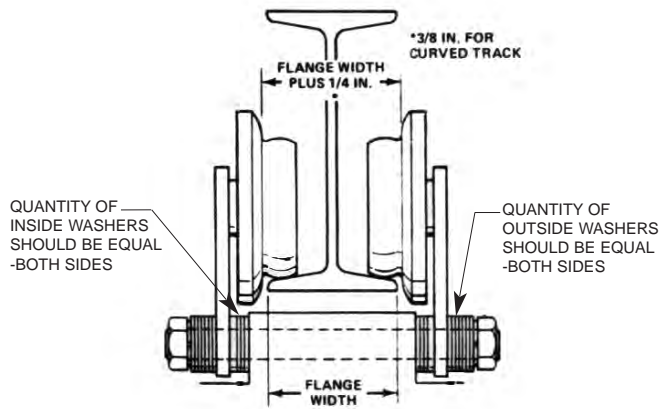

Figure 1.

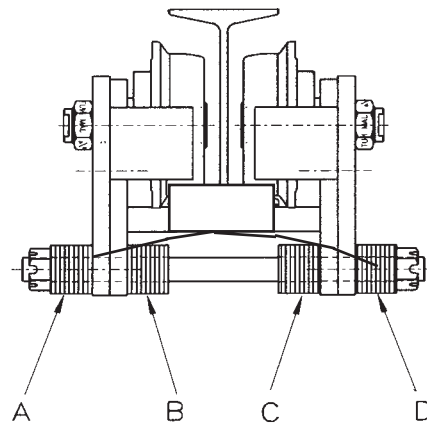

Figure 2.

Table 2. Trolley Spacer Washer Arrangement

	Flange Width in.(mm)	2 Ton			
		No. of Washers			
		A	B	C	D
Standard Trolleys	3-3/8 (85.7)	13	0	0	13
	3-5/8 (92.0)	11	2	2	11
	3-7/8 (98.4)	10	3	4	9
	4 (101.6)	9	4	4	9
	4-1/8 (104.7)	8	5	5	8
	4-5/8 (117.4)	5	8	8	5
	5 (127.0)	3	10	10	3
	5-1/8 (130.1)	3	10	11	2
Special Trolleys	5-1/4 (133.3)	2	11	12	1
	5-1/2 (139.7)	0	13	13	0
	5-5/8 (142.9)	12	1	1	12
	6 (152.4)	10	3	3	10
	6-1/4 (158.7)	9	4	5	8
	6-3/8 (161.9)	8	5	6	7
	7 (177.8)	4	9	9	4
	7-1/8 (181.0)	3	10	10	3
	7-1/4 (184.1)	3	10	11	2
	7-3/8 (187.3)	2	11	12	1
7-1/2 (190.5)	1	12	12	1	
7-5/8 (193.7)	0	13	13	0	
* Minimum Beam Radius ft.(M)		4'-0" (1.22)			

\*Dimension applies to minimum S-beam and will vary with larger S-beams

Before installing geared or motor driven trolleys (2 ton only) on the beam, lubricate the trackwheel gears and pinion with Texaco Novatex #2 or equivalent heavy cup grease.

On open end beams, remove rail stops, lift hoist/trolley into position and slide the hoist/trolley assembly onto beam flange. Reinstall the rail stops.

On closed end beams, loosen the suspension bolt nuts on one side of trolley and slide one side frame out far enough to clear the beam flange. Lift hoist/trolley assembly up so that trackwheels are riding on beam flange. Draw side frames together by tightening the suspension bolt nuts snugly.

Be sure to install cotter pins through slotted nuts and hole in suspension bolts and spread legs of cotter pins to secure on 2 ton units. For 3-7 1/2 ton units, be sure lock-washers are positioned properly on the suspension pins and completely tightened.

On geared trolleys, the bottom of the hand chain loop is normally located two feet (0.6M) above the floor. If it is desired to change this, find the unwelded link and open it by spreading with a chisel or twist one end with a wrench while holding the other end in a vise or another wrench. Remove an even number of links (2,4,6, etc.) as necessary to shorten the chain or add an even number of links to lengthen the chain (when lengthening the chain, another open link will be required and this can be made from a welded link by cutting through weld with a hacksaw). Make certain that the chain is not twisted—then re-install and close open links.

**NOTE: AFTER THE UNIT IS CONNECTED TO THE POWER SUPPLY SYSTEM (SEE BELOW), SUSPEND A CAPACITY LOAD FROM THE HOIST AND OPERATE THE TROLLEY OVER THE ENTIRE LENGTH OF THE RUNWAY OR MONORAIL SYSTEM TO BE SURE THAT THE ADJUSTMENTS AND OPERATION IS SATISFACTORY. ON SYSTEMS WITH CURVES, THE EDGES OF THE RAIL AT THE CURVED SECTIONS SHOULD BE KEPT LIGHTLY LUBRICATED WITH GREASE.**

<b>⚠ WARNING</b>
An excessively worn beam flange may fail and allow the trolley to fall from the beam.
<b>TO AVOID INJURY:</b>
Periodically inspect the beam flange for wear. Replace beam if flange is worn.

### INSTALLING BREATHER

After the hook suspension is assembled to the hoist or after the hoist and trolley are mounted on the beam, remove the upper plug from the main housing (652-110) and install the breather (from small envelope attached to the power cord). Failure to install the breather could damage oil seals and thus cause oil leaks.

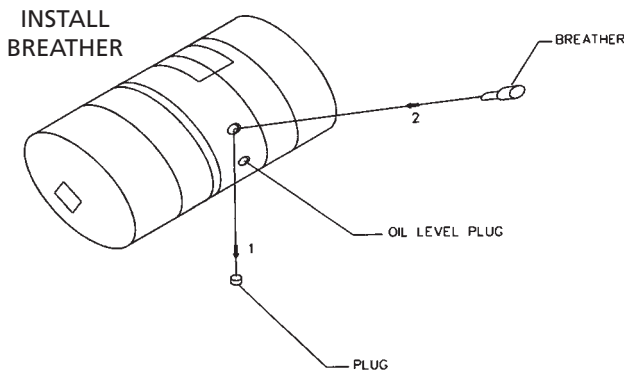

### POWER SUPPLY SYSTEM

To insure proper operation, to avoid damage to hoist and electrical system and to reduce the risk of electric shock or fire, the branch circuit supplying power to the hoist must:

1. Have ample capacity to prevent excess voltage drop during starting and operation (refer to "Checking for Adequate Voltage at Hoist" See Pg. 10). When determining the size of branch circuit components and conductors, special consideration should be given to the starting current-amps (approximately three times that shown on the hoist identification plate) and the length of the conductors. As a minimum, the system should be rated for 20 amps and it should have #12AWG, or larger, wiring.
2. Be in accordance with the National Electrical Code (ANSI/NFPA-70) and applicable National, State and Local Codes.
3. Effectively ground the hoist in accordance with National Electrical Code and other applicable codes. Proper grounding provides a path of least resistance for electric current to reduce the risk of electric shock. The power cord of the hoist includes a green wire for grounding the hoist to the external power supply system. If grounding is to be through the trolley trackwheels, each section of the runway must be grounded to the building ground system using metal to metal connections.
4. Include slow blow type fuses or inverse trip time circuit breakers to permit the hoist to start and accelerate load.
5. Include a disconnecting means capable of being locked in the "open" position.

<b>⚠ WARNING</b>
Failure to properly ground the hoist presents the danger of electric shock.
<b>TO AVOID INJURY:</b>
Permanently ground the hoist as instructed in this manual.

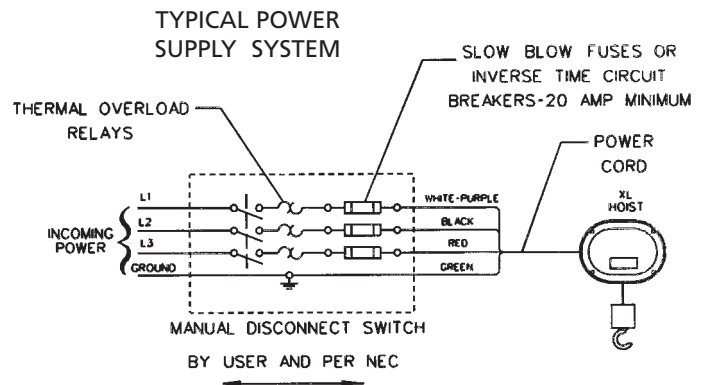

**⚠ WARNING**

Failure to provide a proper power supply system for the hoist may cause hoist damage and offers the potential for a fire.

**TO AVOID INJURY:**

Provide the hoist with a 20 amp, minimum, overcurrent protected power supply system per the National Electrical Code (ANSI/NFPA 70) and applicable local codes as instructed in this manual.

**NOTE: IN THIS MANUAL, NOMINAL VOLTAGES ARE USED WHEN REFERRING TO POWER SUPPLY SYSTEMS. HOWEVER, WITH NO MODIFICATION, THE XL HOIST WILL OPERATE ON A RANGE OF VOLTAGES AS INDICATED BELOW:**

NOMINAL VOLTAGE	VOLTAGE RANGE	HERTZ
230	208-240	60
460	440-480	60
220	200-240	50
380	365-395	50
415	400-430	50
575	550-575	60

**ELECTRICAL CONNECTIONS  
SINGLE SPEED, DUAL VOLTAGE HOISTS (AND  
MOTOR DRIVEN TROLLEYS)**

Unless ordered on a special basis, single speed dual voltage (230/460-3-60, 220/380-3-50 and 220/415-3-50) hoists are factory wired to operate on 460-3-60 (or 380-3-50 or 415-3-50). However, a conversion terminal board is provided to easily and quickly change from 460 to 230 (or 380 to 220 or 415 to 220) volt operation. The conversion terminal board is located adjacent to the reversing contactor at motor end of hoist. If necessary, change voltage connections before connecting hoist to power supply system as follows:

1. Remove the motor cover (652-182). On units with hook suspension, it will be necessary to remove the counterweight (652-219) before removing motor cover.
2. Shift all eight wires from row of terminals marked "460" (or 380 or 415) to row of terminals marked "230" (or 220).

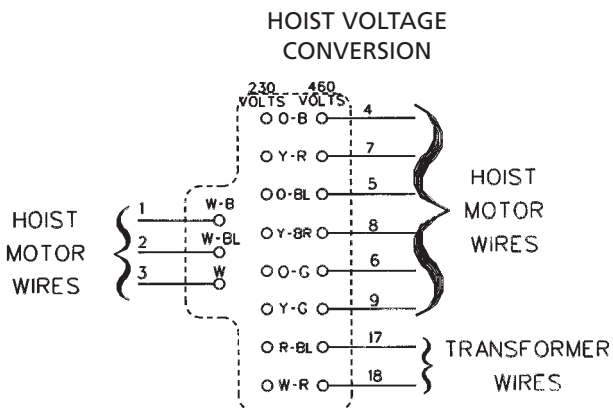

3. Reassemble motor cover (and counterweight if so equipped) to hoist frame.
4. Mark the tag attached to power cord to indicate that the hoist has been converted to operate on 230 (or 220) volts and restamp hoist identification plate accordingly.

If the hoist is suspended from a single speed motor driven trolley, it will also be necessary to change the trolley motor connections. To do this, remove the cover from the terminal box mounted on the side of the trolley motor and reconnect the trolley motor wires attached to the terminal board as shown below:

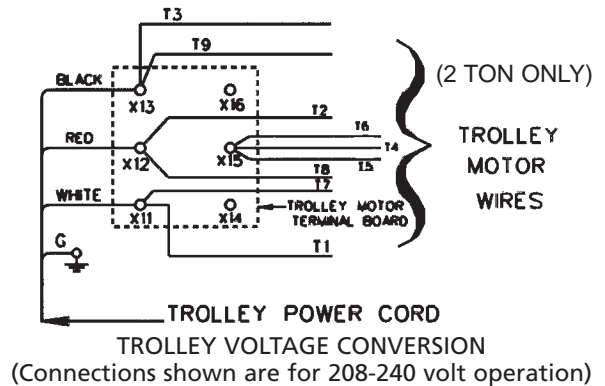

**ALL HOISTS**

After making sure that the hoist (and motor driven trolley) are wired to operate on the power supply system, you are now ready to connect hoist power cord to the power supply. Since these are three phase units, the hoist motor can rotate in either direction depending on how it is connected to the power supply. Therefore, direction of hook movement must be checked during the original installation and each time the hoist is moved to a new location.

Always disconnect the hoist from the power supply system or de-energize the power supply system and follow proper Lockout/Tagout procedures when working (connecting or disconnecting) with the hoist electrical connections.

**⚠ WARNING**

FAILURE TO FOLLOW PROPER LOCKOUT/TAGOUT PROCEDURES MAY PRESENT THE DANGER OF ELECTRICAL SHOCK.

**TO AVOID INJURY:**

DISCONNECT POWER AND LOCKOUT/TAGOUT DISCONNECTING MEANS BEFORE REMOVING COVER OR SERVICING THIS EQUIPMENT.

Serious damage will result if the hook is run to upper or lower limit of lift with hook moving in a direction opposite to that indicated by the control station. Connect hoist power cord to the power supply and check hook movement as follows:

1. Move the manual disconnect switch handle to the "OFF" position.
2. Connect the WHITE-PURPLE, RED AND BLACK wires of hoist power cord to load side of disconnect switch. Connect the GREEN wire of hoist power cord to power supply ground.

3. Move the manual disconnect switch handle to the "ON" position.
4. Depress the  (up) control. If the hook moves in the up direction, the hoist is ready for operation. If the hook lowers, move the disconnect switch handle to the "OFF" position and interchange the BLACK and RED leads at the disconnect switch. Move the disconnect switch handle to the "ON" position and the hoist is now ready for operation.

 <b>WARNING</b>
Allowing the hook block to run into the bottom of the hoist when raising a load or allowing the chain to become taut between the loose end screw and the frame when lowering a load may break the chain and allow the load to drop.
<b>TO AVOID INJURY:</b>
Do not allow the hook block to contact the bottom of the hoist or the loose end chain to become taut.

**NOTE: DO NOT CHANGE INTERNAL WIRING OF HOIST OR CONTROL STATION TO REVERSE HOOK DIRECTION. THE HOIST AND CONTROL STATION WIRING WAS INSPECTED AND TESTED FOR PROPER OPERATION AT THE FACTORY. CHANGING THIS WIRING WILL CAUSE IMPROPER OPERATION AND SERIOUS DAMAGE.**

Also, do not force the Protector to compensate for improperly adjusted limit switches or reverse voltage phasing.

### CHECKING FOR TWIST IN LOAD CHAIN

#### 3, 4 And 5 Ton Double Reeved Units

The best way to check for this condition is to run the lower hook, without a load, up to within about 2 feet (0.6M) of hoist. If the dead end of chain has been properly installed, a twist can occur only if the lower hook block has been capsized between the strands of chain. Reverse capsize to remove twist.

#### 5,6 And 7 1/2 Ton Triple Reeved Units

On these models, the load chain is dead ended on top of the lower hook block. If chain has been properly installed, the only way a twist can occur is if the lower hook block has been capsized between the strands of chain. If this has occurred, two strands of chain will be wrapped around each other and to remove twist, reverse the capsize.

### CHECKING FOR ADEQUATE VOLTAGE AT HOIST

The hoist must be supplied with adequate electrical power for proper operation and to reduce problems that may result from insufficient power (low voltage). These include:

- Noisy hoist operation due to brake and/or contactor chatter.
- Heating of the hoist motor and other internal components as well as heating of wires and connectors in the circuit feeding the hoist.
- Failure of the hoist to lift the load due to motor stalling.
- Blowing fuses or tripping circuit breakers.



For proper operation and to avoid these low voltage problems, voltage (measured at the end of the 2.5 foot (.9 M) power cord while lifting rated load) should be as follows:

NOMINAL POWER SUPPLY	MINIMUM OPERATING VOLTAGE	* MIN. VOLTAGE AT INSTANT OF START
208-3-60	187	172
220-3-50	198	182
230-3-60	207	190
380-3-50	365	336
415-3-50	399	367
460-3-60	414	380

\* The drop in voltage upon energizing the hoist should not be below the value listed.

Remember, operation with low voltage can void the Repair/Replacement policy. When in doubt about any of the electrical requirements for the power supply system, consult a qualified electrician.

### CHECKING LIMIT SWITCH OPERATION

1. Press the  (Up) control and raise the lower hook until the top of the hook block is about one foot (0.3M) below hoist.
2. Cautiously continue raising the hook until upper limit switch stops upward motion. At this point, the top of the hook block should be 3 inches (76 mm) below bottom of the hoist.
3. If adjustment is necessary, see page 16.
4. Press  (Down) control and cautiously lower hook until lower limit switch stops the downward motion. From 10 to 12 chain links should be between the loose end link and the opening for the chain in bottom of hoist. If adjustment is necessary, see page 16.

 <b>WARNING</b>
Allowing the hook block to run into the bottom of hoist when raising a load or allowing the chain to become taut between the loose end screw and the frame when lowering a load may break the chain and allow the load to drop.
<b>TO AVOID INJURY:</b>
Do not allow the hook block to contact the bottom of hoist or the loose end chain to become taut.

### CHAIN CONTAINER

If a chain container is to be used, attach it to the hoist frame and place chain in container per instructions provided with the chain container kit. After the chain container is installed, follow the instructions on page 16 to reset upper limit switch so uppermost point of hook travel is just below the bottom of the chain container.

**UNDER NO CIRCUMSTANCES SHOULD THE HOOK BLOCK OR LOAD BE PERMITTED TO COME IN CONTACT WITH THE CHAIN CONTAINER. IF CONTACT IS MADE, THE FUNCTION OF THE CHAIN CONTAINER CAN BE INTERFERED WITH, THE CONTAINER MAY BE DAMAGED AND IT COULD FALL OFF OF THE HOIST.**

### CONTROL CORD

Unless ordered on a special basis, the hoist is supplied with a control cord that will position the control station approximately 4 feet (1.2M) above the lower hook when it is at the lower limit of lift. If this places the control station too close to the floor, a "control cord alteration kit" (Key No. 627-474, Part Number 28642) can be obtained from factory for shortening the length of the control cord.

## **WARNING**

Tying knots or loops to shorten the drop of the control station will make the strain relief ineffective and the internal conductors of the cord may break.

### **TO AVOID INJURY:**

Shorten the control cord using the control cord alteration kit and the instructions provided with the kit.

## **OPERATING INSTRUCTIONS**

### **GENERAL**

1. The Protector is designed to allow the first reduction gear to slip on an excessive overload. An overload is indicated when the hoist will not raise the load. Also, some clutching noise may be heard if the hoist is loaded beyond rated capacity. Should this occur, immediately release the  (Up) control to stop operation of the hoist. At this point, the load should be reduced to the rated hoist capacity or the hoist should be replaced with one of the proper capacity. When the excessive load is removed, normal hoist operation is automatically restored.

**CAUTION: THE PROTECTOR IS SUSCEPTIBLE TO OVER HEATING AND WEAR WHEN SLIPPED FOR EXTENDED PERIODS. UNDER NO CIRCUMSTANCE SHOULD THE PROTECTOR BE ALLOWED TO SLIP FOR MORE THAN A FEW SECONDS.**

Due to the above, a hoist equipped with a Protector is not recommended for use in any application where there is a possibility of adding to an already suspended load to the point of overload. This includes \*dumbwaiter installations, containers that are loaded in mid-air, etc.

\*Refer to limitations on Page ii concerning dumbwaiter applications.

Also, if a XL Hoist with a Protector is used at unusual extremes of ambient temperatures, above 150°F (65°C) or below 15° F (-9°C) changes in lubricant properties may permit the hoist to raise larger loads than under normal operating conditions and presents possibility of damage or injury.

2. All hoists are equipped with an adjustable screw limit switch, which automatically stops the hook at any predetermined point when either hoisting or lowering.
3. The control station used on two speed hoists is similar to single speed unit, except that either of two definite speeds may be selected by the operator in both hoisting and lowering. Each control when partially depressed provides SLOW speed and when fully depressed gives FAST speed. Partial release of control returns hoist to slow speed, while complete release allows hoist to stop. Rated lifting speeds are shown on hoist identification plate. SLOW speed is intended as a means of carefully controlling or "spotting" the load, although the hoist may be operated solely at this speed if desired. It is not necessary to operate in the SLOW speed position as the hoist will pick up a capacity load at FAST speed from a standing start. In other words, it is not necessary to hesitate at the slow position when moving control from STOP and FAST position or vice versa.

4. If material being handled must be immersed in water, pickling baths, any liquid, dusty or loose solids, use a sling chain of ample length so that the hook is always above the surface. Bearings in the hook block are shielded only against ordinary atmospheric conditions.
5. Read operation section of American National Standard ASME B30.16.

### **ALL HOISTS**

1. Before picking up a load, check to see that the hoist is directly overhead.
2. WHEN APPLYING A LOAD, IT SHOULD BE DIRECTLY UNDER HOIST OR TROLLEY. AVOID OFF-CENTER LOADING OF ANY KIND.
3. Take up a slack load chain carefully and start load easily to avoid shock and jerking of hoist load chain. If there is any evidence of overloading, immediately lower the load and remove the excess load.
4. Do not allow the load to swing or twist while hoisting.
5. Do not allow the load to bear against the hook latch.

### **HOIST WITH PLAIN TROLLEY**

This unit should be moved by pushing on the suspended load or by pulling the empty hook. However, the unit can also be moved by pulling on the control station since an internal steel cable extends the length of the control cord and is anchored to the hoist and to the control station.

### **HOIST WITH GEARED TROLLEY**

This unit should be moved by means of the pendant hand chain. Pull on the chain farthest from end toward which the unit is to travel.

### **HOIST WITH MOTOR DRIVEN TROLLEY**

This unit should be moved by operating the controls marked < FORWARD and > REVERSE in control station. Anticipate the stopping point and allow trolley to coast to a smooth stop. Reversing or "plugging" to stop trolley causes overheating of motor and swaying of load.

### **SAFETY PROCEDURES**

For safety precautions and a list of Do's and Do Not's for safe operation of hoists, refer to page ii.

1. When preparing to lift a load, be sure that attachments to hook are firmly seated in hook saddle. Avoid off center loading of any kind, especially loading on the point of hook.
2. When lifting, raise load only enough to clear the floor or support and check to be sure that the attachments to the hook and load are firmly seated. Continue lift only after you are assured the load is free of all obstructions.
3. Do not load hoist beyond the rated load shown on hoist identification plate and capacity labels. Overload can cause immediate failure of some load-carrying part or create a defect causing subsequent failure at less than rated load. When in doubt, use the next larger capacity of XL Hoist.

4. Do not use this or any other overhead materials handling equipment for lifting persons.
5. Stand clear of all loads and avoid moving a load over the heads of other personnel. Warn personnel of your intention to move a load in their area.
6. Do not leave load suspended in air unattended.
7. Permit only qualified personnel to operate unit.
8. Do not wrap the load chain around the load and hook onto itself as a choker chain.  
Doing this will result in:
  - a. The loss of the swivel effect of the hook which could mean twisted chain and a jammed lift wheel.
  - b. The upper limit switch is by-passed and the load could hit the hoist.
  - c. The chain could be damaged at the hook.
9. On double and triple reeved hoists, check for twists in the load chain. A twist can occur if the lower hook block has been capsized between the strands of chain. Reverse the capsize to remove the twist.
10. Do not allow the load to bear against the hook latch. The latch is to help maintain the hook in position while the chain is slack before taking up slack chain.

**⚠ WARNING**

Allowing the load to bear against the hook latch and/or hook tip can result in loss of load.

**TO AVOID INJURY:**

Do not allow the load to bear against the hook latch and/or hook tip. Apply load to hook bowl or saddle

11. Take up a slack load chain carefully and start load easily to avoid shock and jerking of hoist load chain. If there is any evidence of overloading, immediately lower the load and remove the excess load.
12. Do not allow the load to swing or twist while hoisting.
13. Never operate the hoist when flammable materials or vapors are present. Electrical devices produce arcs or sparks that can cause a fire or explosion.
14. STAY ALERT! Watch what you are doing and use common sense. Do not use the hoist when you are tired, distracted or under the influence of drugs, alcohol or medication causing diminished control.

## MAINTENANCE

### INSPECTION

To maintain continuous and satisfactory operation, a regular inspection procedure must be initiated to replace worn or damaged parts before they become unsafe. Inspection intervals must be determined by the individual application and are based on the type of service to which the hoist will be subjected and degree of exposure to wear, deterioration or malfunction of the critical components.

The type of service to which the hoist is subjected can be classified as "Normal," "Heavy," or "Severe."

**Normal Service:** Involves operation with randomly distributed loads within rated load limit, or uniform loads less than 65 percent of rated load for not more than 25 percent of the time.

**Heavy Service:** Involves operating the hoist within rated load limit which exceeds normal service.

**Severe Service:** Normal or heavy service with abnormal operating conditions.

Two classes of inspection—**Frequent and Periodic**—must be performed.

**FREQUENT INSPECTIONS:** These inspections are visual examinations by the operator or other designated personnel. Records of such inspections are not required. The frequent inspections are to be performed monthly for normal service, weekly to monthly for heavy service, and daily to weekly for severe service, and they should include those items listed in Table 3.

**PERIODIC INSPECTIONS:** These inspections are visual inspections of external conditions by an appointed person. Records of periodic inspections are to be kept for continuing evaluation of the condition of the hoist. Periodic inspections are to be performed yearly for normal service, semi-annually for heavy service and quarterly for severe service, and they are to include those items listed in Table 4.

**CAUTION: ANY DEFICIENCIES ARE TO BE CORRECTED BEFORE THE HOIST IS RETURNED TO SERVICE. ALSO, THE EXTERNAL CONDITIONS MAY SHOW THE NEED FOR DISASSEMBLY TO PERMIT A MORE DETAILED INSPECTION, WHICH, IN TURN, MAY REQUIRE THE USE OF NONDESTRUCTIVE TYPE TESTING.**

### HOOK INSPECTION

Hooks damaged from chemicals, deformations or cracks, or that have more than a 10° twist from the hook's unbent plane, excessive opening or seat wear must be replaced. Also, hooks that are opened and allow the latch to not engage the tip must be replaced. Any hook that is twisted or has excessive throat opening indicates abuse or overloading of the unit. Inspect other load sustaining parts for damage.

On latch type hooks, check to make sure that the latch is not damaged or bent and that it operates properly with sufficient spring pressure to keep the latch tightly against the tip of the hook and allow latch to spring back to tip when released. If latch does not operate properly, it should be replaced. See below to determine when the hook must be replaced.



LATCH TYPE HOOK  
(Upper and Lower)  
TO MEASURE OPENING,  
DEPRESS LATCH AGAINST  
HOOK BODY AS SHOWN.

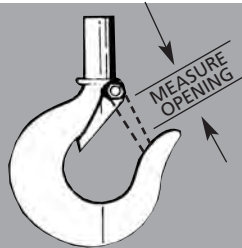

\*UPPER HOOK NOT AVAIL ABLE  
FOR 7 1/2 TON

CAPACITY (TONS)	Replace Hook When Opening Is Greater Than
2	1 1/2 IN. 38.1 mm
3,4,5,6 AND 7 1/2	2 3/8 IN. 60.3 mm

LATCHLOCK® TYPE HOOK  
(UPPER AND LOWER)

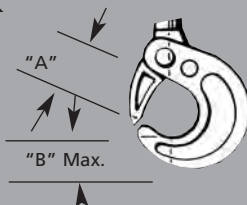

CAPACITY (TONS)	Replace Hook When Opening Or Seat are:	
	"A" Max.	"B" Mn.
2	2 1/2 IN. 63.5 mm	1 1/8 IN. 28.5mm
3,4,5, and 6	2 15/16 IN. 74.6 mm	1 13/32 IN. 35.7mm

### Hook Inspection

## LOAD CHAIN

### Cleaning and Inspection

First clean load chain with a non-acid or non-caustic type solvent. Then slack the chain and make a link-by-link inspection for nicks, gouges, twisted links and excessive wear or stretching. Chain exhibiting wear should be checked throughout its entire length and replaced if worn beyond serviceable limits.

### Checking For Load Chain Wear

Slack the portion of the chain that normally passes over the liftwheel. Examine the interlink area for the point of maximum wear (polishing). Measure and record the stock diameter at this point of the link. Then measure stock diameter in the same area on a link that does not pass over the liftwheel (use the link adjacent to the loose end link for this purpose). Compare these two measurements. If the stock diameter of the worn link is 0.010 inches (0.254mm), or greater, less than the stock diameter of the unworn link, the chain must be replaced.

Note that worn chain can be an indication of worn hoist components. For this reason, the hoist's chain guides, hook blocks and liftwheel should be examined for wear and replaced as necessary when replacing worn chain.

Also, these chains are specially heat treated and hardened and should never be repaired.

### **! WARNING**

Using other than factory supplied load chain may cause the chain to jam in the hoist and/or allow the chain to break and the load to drop.

### **TO AVOID INJURY:**

Due to size requirements and physical properties, use only Hoistaloy® load chain in the XL Hoists.

### **IMPORTANT:**

**DO NOT USE REPLACED CHAIN FOR OTHER PURPOSES SUCH AS LIFTING OR PULLING. LOAD CHAIN MAY BREAK SUDDENLY WITHOUT VISUAL DEFORMATION. FOR THIS REASON, CUT REPLACED CHAIN INTO SHORT LENGTHS TO PREVENT USE AFTER DISPOSAL.**

### **PROTECTOR™**

The Protector should operate for the normal life of hoist without service. The device has been calibrated at the factory for a specific capacity/gear ratio of XL Hoist. It is not adjustable and it is not interchangeable with other capacities/gear ratios.



XL Hoist with  
Motor Driven  
Trolley

Table 3. Minimum Frequent Inspections

TYPE OF SERVICE			ITEM
Normal	Heavy	Severe	
↑ Monthly ↓	↑ Weekly to Monthly ↓	↑ Daily to Weekly ↓	a) Brake for evidence of slippage. b) Control functions for proper operation. c) Hooks for damage, cracks, twists, excessive throat opening. latch engagement and latch operation—see page 13. d) Load chain for adequate lubrication, as well as for signs of wear, damaged links or foreign matter—see page 15. e) Load chain for proper reeving and twists.

Table 4. Minimum Periodic Inspections

TYPE OF SERVICE			ITEM
Normal	Heavy	Severe	
↑ Yearly ↓	↑ Every 6 Months ↓	↑ Every 3 Months ↓	a) All items listed in Table 3 for frequent inspections. b) External evidence of loose screws, bolts or nuts. c) External evidence of worn, corroded, cracked or distorted hook block, gears, bearings, dead end block, dead end pin, dead end bolt and suspension components. d) External evidence of damage to hook retaining nut and pin. Also check the upper suspension adapter making sure it is fully seated in the hoist frame and that suspension adapter screw or dead end bolt is tight. e) External evidence of damage or excessive wear of the liftwheel and hook block sheave chain pockets. Widening and deepening of the pockets may cause the chain to lift-up in the pocket and result in binding between liftwheel and chain guide or between the sheave and hook block. Also, check the chain guide for wear or burring where the chain enters the hoist. Severely worn or damaged parts should be replaced. f) External evidence of excessive wear of brake parts, and brake adjustment—see page 15. g) External evidence of pitting or any deterioration of contactor contacts. Check the operation of the control station making sure the buttons operate freely and do not stick in either position. h) Inspect the electrical cords and cables and control station enclosure for damaged insulation. i) Inspect trolley trackwheels for external wear on tread and flange and for wear on internal bearing surfaces as evidenced by a looseness on the stud. Suspension components for damage, cracks, wear and operation. Also check suspension adapter screw or dead end bolt for proper tightness—(see pages 4, 5, and 6). j) Inspect the loose end link, loose end screw, dead end block on double reeved units and dead end plate on triple reeved units. Replace worn or distorted parts. k) Inspect the hook for excess free play or rotation. Replace worn parts as evidenced by excess free play or rotation. l) Inspect for oil leaks at the gasket on either side of intermediate plate. Tighten the screws used to attach the main housing and brake housing to intermediate plate. If leak persists, disassemble hoist (see page 27) and replace gaskets. m) Inspect inside of motor and brake housings for presence of oil. Oil in motor housing may be excess chain lubricant or a leaking seal. Wipe out oil and monitor. If leak persists, replace seal (652-122 or 652-132). Oil in brake housing is due to leaking seal. Replace seal (652-122 or 652-134). n) Check motor bolts for damage and replace if bent, cracked or damaged. o) Inspect all splines for signs of wear and deterioration. Replace splined parts if worn or damaged.

## LUBRICATION

### **! WARNING**

The lubricants used in and recommended for the XL Hoist may contain hazardous materials that mandate specific handling and disposal procedures.

#### **TO AVOID CONTACT AND CONTAMINATION:**

Handle and dispose of lubricants only as directed in applicable material safety data sheets and in accordance with applicable local, state and federal regulations.

**NOTE: TO ASSURE EXTRA LONG LIFE AND TOP PERFORMANCE, BE SURE TO LUBRICATE THE VARIOUS PARTS OF THE XL HOIST USING THE LUBRICANTS SPECIFIED BELOW. IF DESIRED, THESE LUBRICANTS MAY BE PURCHASED FROM THE FACTORY.**

### HOIST LUBRICATION

**Gears.** Check oil level in gear housing at least once a month, maintaining it at the bottom of oil level hole in main housing (652-110).

Drain housing every 2-3 years and refill with one gallon (3.86 liters) of gear oil Amoco 85W-140.

**CAUTION: THE PROTECTOR IS TO OPERATE IN THE ABOVE MENTIONED OIL. DO NOT USE ANY OTHER TYPE OF LUBRICANT OR THE PROTECTOR WILL NOT OPERATE PROPERLY AND PARTS COULD BE DAMAGED.**

The limit switch gears are of molded nylon and require no lubrication. Apply a light film of machine oil to the limit switch shaft threads at least once a year.

#### **Chain Guides, Liftwheel & Sheave Wheels.**

When the hoist is disassembled for inspection and/or repair, the chain guides, sheave wheels (on multi-reeved units) and liftwheel must be lubricated with Lubriplate Bar and Chain Oil 10-R (Fiske Bros. Refining Co.) prior to reassembly. Apply sufficient lubricant to obtain natural runoff and full coverage.

**Load Chain.** Keep chain lubricated with a small amount of lubricant. This will greatly increase the life of load chain. Do not allow the chain to run dry.

Keep it clean and lubricate at regular intervals with Lubriplate Bar and Chain Oil 10-R (Fiske Bros. Refining Co.) or equal lubricant. Normally, weekly lubrication and cleaning is satisfactory, but under hot and dirty conditions, it may be necessary to clean the chain at least once a day and lubricate it several times between cleanings. When lubricating the chain, apply sufficient lubricant to obtain natural runoff and full coverage.

### **! WARNING**

Used motor oils contain known carcinogenic materials.

#### **TO AVOID HEALTH PROBLEMS:**

Never use used motor oils as a chain lubricant. Only use Lubriplate Bar and Chain Oil 10-R as a lubricant for the load chain.

**Bearings.** All bearings except the lower hook thrust bearings are pre-lubricated or are in an oil bath and need no lubrication. The lower hook thrust bearing should be lubricated at least once a month with heavy duty machine oil.

**Miscellaneous.** If unit is disassembled, splines inside coupling (652-103) should be coated with an EP type grease (such as Evans Products Co. Anti-Scoring Extreme Pressure Lub. No. 3) before reassembly.

### TROLLEY LUBRICATION

Trackwheel bearings are pre-lubricated and require no lubrication.

**Geared Trolley.** Once a month lubricate trackwheel gears with Texaco Novatex No. 2 or an equivalent heavy cup grease or graphite grease.

Every six months lubricate handwheel shaft bearings in 3-in-1 machine oil.

**Motor Driven Trolley.** Once a month lubricate trackwheel gears with Texaco Novatex No. 2 or an equivalent heavy cup grease or graphite grease.

For 2 ton trolleys, the motor bearings and reduction gears require no additional lubrication. However, if gears are disassembled, upon reassembly use Texaco Novatex No. 1 or an equivalent medium cup grease.

For 3-7 1/2 ton trolleys, the right angle worm gear reducer oil should be changed after the first 100 hours of operation, then after every 2500 hours of normal service. When replacing oil due to repairs or service, use Mobil SHC-626 or equal, for each oil change.

## ADJUSTMENTS

### HOIST BRAKE

The correct air gap between armature and field when brake is not energized, is 0.025 inch (.63 mm) and need not be adjusted until the gap reaches 0.045 inch (1.14 mm).

To adjust the brake, proceed as follows:

1. Disconnect hoist from power supply.
2. Remove brake end cover.
3. Before adjusting the gap, back off the brake nuts and examine friction linings and friction surfaces for wear, scoring or warpage (min.thk. .188). Also check shading coils to be sure they are in place and not broken. A missing or broken shading coil will cause the brake to be noisy when hoist is operated. Any of these symptoms indicate the need for replacement of parts.
4. Turn brake nuts clockwise gaging the air gap on each side and at both ends of the armature.
5. Replace cover, reconnect the power and check operation.

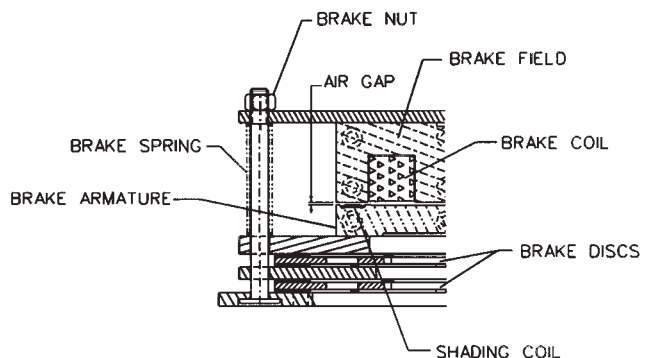

HOIST BRAKE  
ADJUSTMENT

## LIMIT SWITCHES

If limit switch operation has been checked as described on page 10 and is not operating correctly or is not automatically stopping the hook at a desired position, proceed as follows:

1. Disconnect hoist from power supply.
2. Remove brake end cover.
3. The positions of upper and lower limit switches are indicated on the fiber insulator.
4. Loosen the screws to permit guide plate to be moved out of engagement with the traveling nuts.
5. Reconnect hoist to power supply
6. Run hook to the desired upper or lower position, cautiously operating the hoist without load.
7. Disconnect hoist from power supply.
8. Moving one travel nut toward the other increases hook travel and away from the other decreases the travel. To adjust the upper limit, turn the nut nearest the switch indicated as "Upper Limit Switch". To adjust the lower limit, turn the nut nearest the switch marked "Lower Limit Switch". Turn the desired nut until it just breaks the limit switch contacts. An audible click will be heard as the switch opens. Continue to rotate the nut toward the switch an additional two full teeth.
9. Reposition the guide plate in the next slot and securely tighten screws.
10. Reconnect hoist to power supply and check the stopping point of the hook by first moving the hook about 10 inches (254 mm) away from the desired stopping point. Then move the hook towards the desired stopping point by jogging cautiously until the limit switch stops the motion. If the stopping point is not the desired position, repeat the above instructions.
11. Double check the adjustment by moving the hook about 2 feet (610 mm) from the desired stopping point and then run the hook into the limit with the control held in the fully depressed position.
12. Fine adjustment of the screw limits setting may be obtained by inverting the guide plate. The offset on the plate gives adjustments equivalent to 1/2 notch (see Table below). When inverting the plate, it may be necessary to use the notch adjacent to the one used in the preliminary setting.

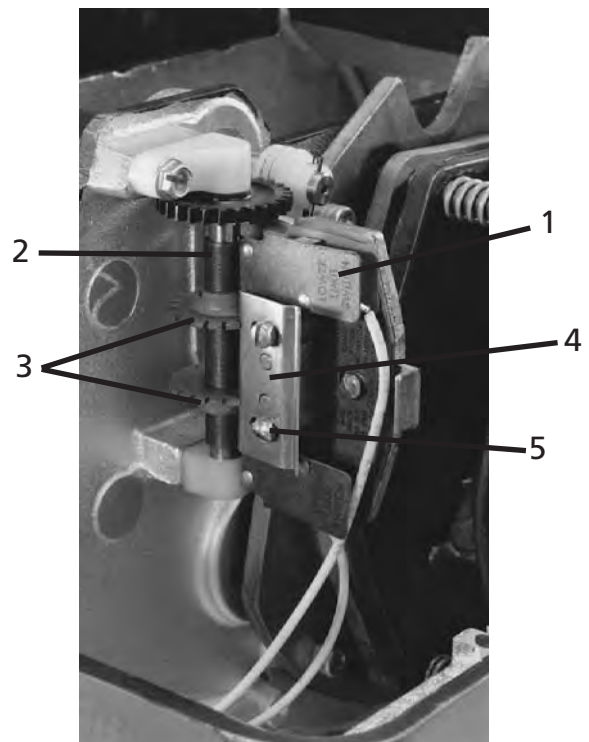

**LIMIT SWITCHES**

- |                          |                |
|--------------------------|----------------|
| 1. Limit switch sub-assy | 4. Guide Plate |
| 2. Limit switch shaft    | 5. Screws      |
| 3. Traveling nuts        |                |

## HOOK TRAVEL PER NOTCH OF LIMIT SWITCH NUT

RATED LOAD TONS (Kg.)	PARTS OF CHAIN (REEVING)	*LIFT SPEED FPM (MPM)	MAX. LIFT FT. (M)	HOOK TRAVEL PER NOTCH IN.(mm)
2 (2000)	1	18 (5.5)	127 (39)	1.10 (27.9)
2 (2000)		24 (7.3)	139 (42)	1.27 (32.3)
2 (2000)		30 (9.1)	71 (22)	0.63 (16.0)
3 (3000)	2	9 (2.7)	60 (18)	0.55 (14.0)
3 (3000)		12 (3.6)	65 (20)	0.64 (16.1)
3 (3000)		15.2 (4.6)	106 (32)	0.93 (23.6)
4 (4000)		9 (2.7)	60 (18)	0.55 (14.0)
4 (4000)		12 (3.6)	65 (20)	0.64 (16.1)
4 (4000)		15.2 (4.6)	106 (32)	0.93 (23.6)
5 (5000)		9 (2.7)	60 (18)	0.55 (14.0)
5 (5000)		12 (3.6)	65 (20)	0.64 (16.1)
5 (5000)		15.2 (4.6)	106 (32)	0.93 (23.6)
5 (5000)	3	6(1.8)	42 (13)	0.37 (9.3)
5 (5000)		8(2.4)	46 (14)	0.42 (10.8)
6 (6000)		6 (1.8)	42 (13)	0.37 (9.3)
6 (6000)		8 (2.4)	46 (14)	0.42 (10.8)
6 (6000)		10 (3.0)	71 (22)	0.63 (16.0)
7½ (7500)		6 (1.8)	42 (13)	0.37 (9.3)
7½ (7500)		10 (3.0)	71 (22)	0.63 (16.0)

\* At 60 Hertz. For 50 Hertz speeds are 5/6 of those listed. Fast speeds are listed for two speed units.

## TROLLEY BRAKE (2 TON UNIT) (Optional Accessory)

The stopping distance of the Motor Driven Trolley equipped with an electric brake can be increased or decreased by adjusting the brake pressure. To increase brake pressure, and thereby decrease stopping distance, move the brake spacer washers progressively from the nut side of the brake field plate to the spring side. To decrease the stopping distance, move the washers in an opposite manner. Both studs must have the same number of washers on the spring side of the brake field plate.

The correct air gap between armature and field, when the brake is not energized, is 0.025 inch (.63 mm) and need not be adjusted until the gap reaches 0.045 inch (1.14 mm).

To adjust the air gap or brake pressure, proceed as follows:

1. Disconnect hoist from power supply.
2. Remove brake cover.
3. Before adjusting air gap or brake pressure:
  - a. Back off the brake nuts and examine friction linings and friction surfaces for excessive wear, scoring or warpage.
  - b. Check shading coils to be sure they are in place and not broken. A missing or broken shading coil will cause the brake to be noisy when trolley is operated.

Any of these symptoms indicate the need for replacement of parts.

4. If brake pressure is to be adjusted, move brake spacer washers to the desired side of the brake field plate to increase or decrease pressure as indicated above.
5. After spacer washers are positioned, turn brake nuts clockwise gaging the air gap at both ends.
6. Replace brake cover, reconnect the power and check operation. If the stopping distance of the trolley is not as desired, repeat the above.

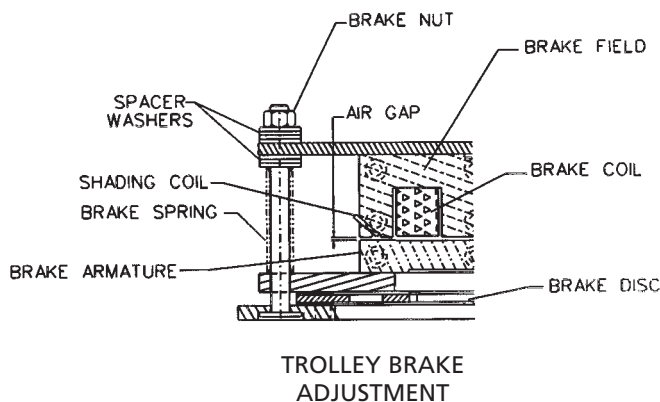

## TROLLEY BRAKE (3 THUR 7½ TON UNITS) (Optional Accessory)

The brake can be ordered with the trolley or it is available in kit form for installation on a unit in the field. To order a brake kit for an existing unit, order brake kit Key No. 29 and indicate the serial number of the trolley on which it is to be installed and the voltage on which the trolley operates.

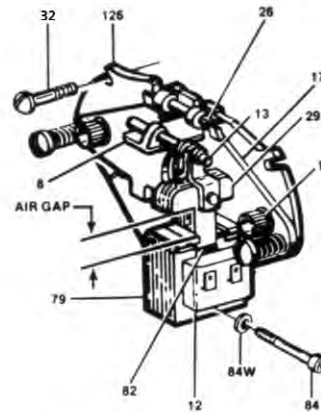

Figure 1. Motor Brake Adjustment

### ADJUSTMENT

The motor brake should be checked periodically for wear of the friction discs and/or proper adjustment of the solenoid air gap. Refer to Figure 1. Normal lining wear will cause the solenoid lever (8) to move away from the solenoid frame (79) and thus increase the air gap and trolley stopping time.

When the air gap reaches approximately 11/16" the brake should be adjusted. To adjust the air gap of the brake, proceed as follows:

1. De-energize the power supply to trolley.
2. Remove both access covers to expose brake.
3. Depress the plunger (13) towards the solenoid frame until spring pressure is felt.
4. Hold the plunger firmly in the position and measure the air gap between the mating (ground) surfaces of the solenoid (79) and the solenoid plunger (29).
5. To adjust, turn both wear adjustment screws (10) equal amounts clockwise until the air gap measures 13/32".

### Replacement of Friction Disc (Refer to Exploded View Drawing, Page 47)

1. De-energize the power supply to the trolley and remove the motor/brake assembly from the gear reducer. Remove housing (3) from the brake.
2. Remove the entire support plate assembly by unscrewing 3 screws (32). Remove the stationary disc (11) and worn friction disc (12). Install the new friction disc, making sure that the two stabilizing springs are at 90° in the recessed portion of the squared hole in the friction disc, with the prongs pointing into the brake. Place the stationary disc on the friction disc and re-assemble the entire support plate assembly engages the guide pins of the end plate.
3. Remove both access covers (5) from the housing (1) and slide the housing with its shaft assembly on to the mounting studs. Be sure the housing is assembled with access windows above the horizontal centerline. Rotate shaft to engage key into the hub keyway.
4. Re-assemble the motor/brake assembly to the gear reducer using the four nuts and lockwashers.
5. Adjust air gap per above instructions (ADJUSTMENTS).
6. Re-energize power supply and operate trolley a few times to make sure air gap is correct and then replace access covers (5).

**Replacement of Coil  
(Refer to Figure 1 on page 17 and Exploded  
View Drawing on page 47).**

1. De-energize the power supply to the trolley and remove the motor/brake assembly from the gear reducer.
2. Remove housing (3) from the brake and disconnect the coil wires from the cord.
3. Insert screw driver between support plate (126, Fig.1) and the top of lever arm (17, Fig.1). Wedge these apart and remove bearing pin (26, Fig.1) and solenoid lever (8, Fig.1) with link (13, Fig.1) and plunger (29, Fig.1).
4. Remove plunger guide screw (84, Fig.1) and both plunger guides (82, Fig.1). Slide old coil sideways out of the frame (79, Fig.1). If coil is difficult to move, tap lightly with a soft hammer.
5. Install new coil in the same relative position as the old coil and replace the plunger guides (82, Fig.1) and screw (84 and 84W, Fig.1).
6. Re-assemble following Step 3 in reverse order.
7. Re-connect the coil leads to the brake coil. Slide housing and shaft assembly onto mounting studs, rotating shaft to engage key into hub keyway. Be sure the access covers are above the horizontal centerline.
8. Re-assemble motor/brake assembly to gear reducer using the four nuts and lockwashers.
9. Adjust air gap per above instructions (ADJUSTMENT).
10. Re-energize power supply and operate trolley a few times to make sure air gap is correct and then replace access covers.

**RECOMMENDED SPARE PARTS**

To insure continued service of the XL Hoist, the following is a list of parts that are recommended to be kept on hand at all times to replace parts that have worn or failed. Parts applicable to your unit should be stocked.

Key No.	Part Name	Qty. for Each Hoist in Service
652-120	Limit Switch Assembly	1
652-130	Brake Coil	1
652-131	Brake Friction Disc	2
652-135	Transformer	1
627-563	Control Station Parts Kit (2 Direction Station)	1
627-565	Control Station Switch Kit (2 Direction Station)	1
635-155	Control Station Switch Kit (4 Direction Station)	1
652-136	Hoist Reversing Contactor	1
652-137	Speed Selecting Contactor (2 Speed Hoists Only)	1
652-138	Trolley Reversing Contactor	1
652-236	Trolley Speed Selector (2 Speed Trolley Only)	1

Refer to page 32 for ordering instructions and the parts list for part numbers.

**PREVENTIVE MAINTENANCE**

In addition to the inspection procedure on page 12, a preventive maintenance program should be established to prolong the useful life of the hoist and maintain its reliability and continued safe use. The program should include the periodic and frequent inspections with particular attention being paid to the lubrication of the various components using the recommended lubricants (see page 15).

# TROUBLE SHOOTING

TROUBLE	PROBABLE CAUSE	CHECK AND REMEDY
<b>ALL HOISTS</b>		
1. Hook does not respond to the control station.	<p>A) No voltage at hoist—mainline or branch circuit switch open; branch line fuse blown or circuit breaker tripped.</p> <p>B) Phase failure (single phasing)—open circuit, grounded or faulty connection in one line of supply system, hoist wiring, reversing contactor, motor leads or windings.</p> <p>C) Upper or lower limit switch has opened the motor circuit.</p> <p>D) Open control circuit—motor thermal switch open; shorted or open winding in transformer, reversing contactor coil or speed selecting contactor coil; loose connection or broken wire in circuit; mechanical binding in contactor; control station contacts not closing or opening.</p> <p>E) Wrong voltage or frequency.</p> <p>F) Low voltage.</p> <p>G) Brake not releasing—open or shorted coil winding; armature binding.</p> <p>H) Excessive load.</p>	<p>A) Close switch, replace fuse or reset breaker.</p> <p>B) Check for electrical continuity and repair or replace defective part.</p> <p>C) Press the “other” control and the hook should respond. Adjust limit switches as described on page 15.</p> <p>D) Check electrical continuity thru thermal switch. If it is open, allow motor to cool. Should this not correct the trouble, check electrical continuity of other parts and repair or replace defective part.</p> <p>E) Use the voltage and frequency indicated on hoist identification plate. For three phase dual voltage unit, make sure the connections at the conversion and trolley terminal boards are the proper voltage as described on page 8.</p> <p>F) Check for low voltage condition as described on page 10.</p> <p>G) Check electrical continuity and connections. Check that correct coil has been installed. The coil for dual voltage unit operates at 230 volts when the hoist is connected for either 230 volt or 460 volt operation. Check brake adjustment as described on page 15.</p> <p>H) Reduce loading to the capacity limit of hoist as indicated on the identification plate.</p>

<b>TROUBLE</b>	<b>PROBABLE CAUSE</b>	<b>CHECK AND REMEDY</b>
2. Hook moves in the wrong direction.	A) Wiring connections reversed at either the control station or terminal board.  B) Phase reversal.	A) Check connections with the wiring diagram.  B) Refer to installation instructions on page 9 (all hoists).
3. Hook lowers but will not raise.	A) Excessive load.  B) Open hoisting circuit—open or shorted winding in reversing contactor coil or speed selecting contactor coil; loose connection or broken wire in circuit; control station contacts not making; upper limit switch contacts open.  C) Phase failure.	A) See Item 1H.  B) See Item 1D. Also check operation of limit switch as described on page 10.  C) See Item 1B.
4. Hook raises but will not lower.	A) Open lowering circuit—open or shorted winding in reversing contactor coil or speed selecting contactor coil; loose connection or broken wire in circuit; control station contacts not making; lower limit switch contacts open.	A) Check electrical continuity and repair or replace defective part. Check operation of limit switch operation as described on page 10.
5. Hook lowers when hoisting control is operated.	A) Phase failure.	A) See Item 1B.
6. Hook does not stop promptly.	A) Brake slipping.  B) Excessive load.  C) Protector slipping.	A) Check brake adjustment as described on page 15.  B) See Item 1H.  C) If Protector is not functioning properly, it should be replaced.
7. Hoist operates sluggishly.	A) Excessive load.  B) Low voltage.  C) Phase failure or unbalanced current in phases.  D) Brake dragging.	A) See Item 1H.  B) Check for low voltage condition as described on page 10.  C) See Item 1B.  D) Check brake adjustment as described on page 15.



<b>TROUBLE</b>	<b>PROBABLE CAUSE</b>	<b>CHECK AND REMEDY</b>
8. Motor overheats.	<p>A) Excessive Load.</p> <p>B) Low Voltage.</p> <p>C) Extreme external heating.</p> <p>D) Frequent starting or reversing.</p> <p>E) Phase failure or unbalanced current in the phase.</p> <p>F) Brake dragging.</p>	<p>A) See Item 1H.</p> <p>B) Check for low voltage condition as described on page 10.</p> <p>C) Above an ambient temperature of 104°F. (40°C.), the frequency of hoist operation must be limited to avoid overheating of motor. Special provisions should be made to ventilate the space of shield the hoist from radiation.</p> <p>D) Avoid excessive inching, jogging or plugging. This type of operation drastically shortens the motor and contactor life and causes excessive brake wear.</p> <p>E) See Item 1B.</p> <p>F) Check brake adjustment as described on page 15.</p>
9. Hook fails to stop at either or both ends of travel.	<p>A) Limit switches not opening circuits.</p> <p>B) Shaft not rotating.</p> <p>C) Traveling nuts not moving along shaft—guide plate loose; shaft or nut threads damaged.</p>	<p>A) Check switch connections, electrical continuity and mechanical operation. Check the switch adjustment as described on page 10. Check for a pinched wire.</p> <p>B) Check for damaged gears.</p> <p>C) Tighten guide plate screws. Replace damaged part.</p>
10. Hook stopping point varies.	<p>A) Limit switch not holding adjustment.</p> <p>B) Brake not holding.</p>	<p>A) See Item 9.</p> <p>B) Check the brake adjustment as described on page 15.</p>

TROUBLE	PROBABLE CAUSE	CHECK AND REMEDY
<b>TWO SPEED HOISTS</b>		
11. Hoist will not operate at slow speed in either direction.	A) Open Circuit.	A) Open or shorted motor winding, loose or broken wire in circuit, speed selecting contactor stuck in opposite speed mode. Replace motor, repair wire and/or replace speed selecting contactor.
	B) Phase failure.	B) See Item 1B.
12. Hoist will not operate at fast speed in either direction.	A) Open circuit.	A) See Item 11A.
	B) Open speed selection circuit.	B) Open or shorted winding in speed selecting contactor coil. Loose connection or broken wire in circuit. Mechanical binding in contactor. Control station contacts not making or opening. Replace speed selecting contactor; repair connection, replace contactor or control station.
	C) Phase failure.	C) See Item 1B.
13. Hook will not raise at slow speed.	A) Excessive load.	A) See Item 1H.
	B) Phase failure.	B) See Item 1B.
	C) Open circuit.	C) See Item 11A.
	D) Brake not releasing.	D) See Item 1G.
14. Hook will not lower at slow speed.	A) Phase failure.	A) See Item 1B.
	B) Open circuit.	B) See Item 11A.
	C) Brake not releasing.	C) See Item 1G.
15. Hook will not raise at fast speed.	A) Excessive load.	A) See Item 1H.
	B) Phase failure.	B) See Item 1B.
	C) Brake not releasing.	C) See Item 1G.
16. Hook will not lower at fast speed.	A) Phase reversal.	A) See Item 1B.
	B) Brake not releasing.	B) See Item 1G.
17. Hook moves in proper direction at one speed—wrong direction at other speed.	A) Phase reversal.	A) Wiring reconnected improperly. Interchange two leads of motor winding that are out of phase at the speed selecting contactor.

TROUBLE	PROBABLE CAUSE	CHECK AND REMEDY
<b>MOTOR DRIVEN TROLLEY</b>		
18) Trolley does not operate in either direction.	<ul style="list-style-type: none"> <li>A) No voltage at motor.</li> <li>B) Phase failure.</li> <li>C) Open control circuit.</li> <li>D) Low voltage.</li> <li>E) Wrong voltage or frequency.</li> </ul>	<ul style="list-style-type: none"> <li>A) Open circuit, grounded or faulty connection in hoist wiring.</li> <li>B) See Item 1B.</li> <li>C) See Item 1D.</li> <li>D) See Item 1F.</li> <li>E) See Item 1E.</li> </ul>
19) Trolley operates in one direction only.	A) Open control circuit.	A) See Item 1D.
20) Trolley operates sluggishly.	<ul style="list-style-type: none"> <li>A) Excessive load.</li> <li>B) Low voltage.</li> <li>C) Unbalanced current in the phases.</li> <li>D) Brake dragging.</li> </ul>	<ul style="list-style-type: none"> <li>A) See Item 1H.</li> <li>B) See Item 1F.</li> <li>C) See Item 1B.</li> <li>D) Check electrical continuity and connections. Check that the correct coil has been installed. The coil for dual voltage units operate on 230 volts when the trolley is connected for either 230 or 460 volt operation. Check brake adjustment as described on page 17.</li> </ul>
21) Trolley motor overheats.		A) See Item 8.

## ELECTRICAL DATA

### TO DETECT OPEN AND SHORT CIRCUITS IN ELECTRICAL COMPONENTS

Open circuits in the coils of electrical components may be detected by isolating the coil and checking for continuity with an ohmmeter or with the unit in series with a light or bell circuit.

Shorted turns are indicated by a current draw substantially above normal (connect ammeter in series with suspected element and impose normal voltage) or D.C.

resistance substantially below normal. The current method is recommended for coils with very low D.C. resistance.

Motor current draw in the stator should be measured with the rotor in place and running. Brake, relay and contactor coil current should be measured with the core iron in operating position.

COILS	VOLTAGE	CURRENT DRAW (AMPS) AT 60 HERTZ	*D.C. RESISTANCE (OHMS)
HOIST REVERSING CONTACTOR COILS	115 48 24	0.09 0.46 0.49	88.4 3.6 3.7
HOIST SPEED SELECTING CONTACTOR COILS	115 48 24	0.11 0.25 N/A	86.8 14.4 N/A
TROLLEY REVERSING CONTACTOR COILS	115 48 24	0.17 0.30 1.00	117.3 18.2 4.7
HOIST BRAKE COILS	**220-240 380-480 575	1.39 0.86 0.39	2.4 9.3 14.9
TROLLEY BRAKE COILS	**220-240 380-480 575	0.27 0.16 0.09	22.8 89.4 143.3
	**220-240 380-480 (2 Ton) 575	0.20 0.08 0.06	-- -- --
TROLLEY SPEED SELECTOR	115 48 24	0.09 0.20 0.47	200.00 31.9 8.6

TRANSFORMERS (652-135)		*D.C. RESISTANCE (OHMS)-LEADS					
VOLTS		16-17	18-19	16-18	16-19	R-R	B-B
PRIMARY	SECONDARY						
208-240/380-480	110-120	43.3	48.1	--	--	7.8	--
208-240/380-480	24	41.2	46.1	--	--	0.4	--
220/380/440	48	21.9	--	58.4	71.9	1.4	--
550/575	110-120	--	--	--	--	7.6	145.5

<b>HOIST MOTORS (652-162)</b>		<b>CURRENT (AMPS)</b>		<b>*D.C. RESISTANCE (OHMS)-LEADS</b>		
VOLTS-PHASE -HERTZ	H.P. (KW)	STARTING	FULL LOAD	1-2	1-2	11-12
				1-3	1-3	11-13
				2-3	2-3	12-13
230/460-3-60	3.5 (2.7)	18.4/6.4	11.5/5.8	4.4	-	-
220/380-3-50	3.5 (2.7)	13.6/6.4	11.9/5.9	4.4	-	-
220/415-3-50	3.5 (2.7)	13.6/6.4	11.9/5.8	4.4	-	-
230/460-3-60	5.7 (4.3)	23.2/8.0	14.5/7.3	2.8	-	-
220/380-3-50	5.7 (4.3)	17.0/8.0	14.9/7.4	2.8	-	-
220/415-3-50	5.7 (4.3)	17.0/8.0	14.9/7.3	2.8	-	-
230-3-60	1.2/3.5 (.9/2.7)	49.2/40.8	12.3/10.2	-	3.0	1.9
220-3-50	1.2/3.5 (.9/2.7)	36.4/26.2	13.0/11.4	-	3.0	1.9
460-3-60	1.2/3.5 (.9/2.7)	25.6/20.4	6.4/5.1	-	10.8	6.3
380-3-50	1.2/3.5 (.9/2.7)	16.8/14.3	6.7/5.7	-	10.8	6.3
415-3-50	1.2/3.5 (.9/2.7)	16.8/14.3	6.7/5.7	-	10.8	6.3
575-3-60	3.5 (2.7)	9.5	3.8	6.9	-	-
575-3-60	1.2/3.5 (.9/2.7)	14.5/11.3	5.8/4.5	-	15.8	9.9

<b>TROLLEY MOTORS (670-407)</b>				<b>*D.C. RESISTANCE (OHMS)-LEADS</b>			
VOLTS (3 PHASE)	HP (KW)	RPM (SYN.) AT 60 HERTZ	FULL LOAD CURRENT (AMPS) AT 60 HERTZ	T1-T4	T7-T8	T1-T2	T11-T12
				T2-T5	T7-T9	T1-T3	T11-T13
				T3-T6	T8-T9	T2-T3	T12-T13
208-240/380-480	.5 (.38)	1200	1.95/.98	15.9	31.2	-	-
208-240/380-480	.5 (.38)	600	3.75/1.88	14	28	-	-
550-575	.5 (.38)	1200	0.70	-	-	101.2	-
550-575	.5 (.38)	600	1.80	-	-	86.3	-
208-240	.25/.50(.19/.38)	600/1200	3.00/2.60	-	-	25.0	27.1
380-480	.25/.50(.19/.38)	600/1200	1.30/1.10	-	-	105.9	106.9
208-240	.25/.50(.19/.38)	900/1800	4.5/8.1	--	--	17.3	30.6
380-480	.25/.50(.19/.38)	900/1800	.8/.7	-	-	67.3	123.4
550-575	.25/.50(.19/.38)	900/1800	.6/.7	-	-	123.0	187.5

<b>TROLLEY MOTORS (BET-3001)</b>				<b>D.C. RESISTANCE (OHMS)-LEADS</b>		
VOLTS (3 PHASE)	H.P. (KW)	RPM (SYN) AT 60 HERTZ	FULL CURRENT (AMPS) AT 60 HERTZ	230 VOLT	460 VOLT	575 VOLT
				CT1-CT2 CT2-CT3 CT1-CT3	CT1-CT2 CT2-CT3 CT1-CT3	CT1-CT2 CT2-CT3 CT1-CT3
208-240/380/480	.25 (.19)	1800	1.35/.65	19.7	78.9	--
208-240/380-480	.5 (.38)	1800	.37	10.3	41.2	--
550-575	.25 (.19)	1800	2.0/1.0	--	--	132.3
550-575	.5 (.38)	1800	.80	--	--	66.2

\*Resistance values are nominal and may vary from component to component.

\*\*On dual voltage units (230/460-3-60, 220/380-3-50 and 220/415-3-60), brake coil operates on 230 (220) volts.

# TYPICAL WIRING DIAGRAMS

Wiring diagrams shown are representative. Consult wiring diagram in hoist or furnished with unit.

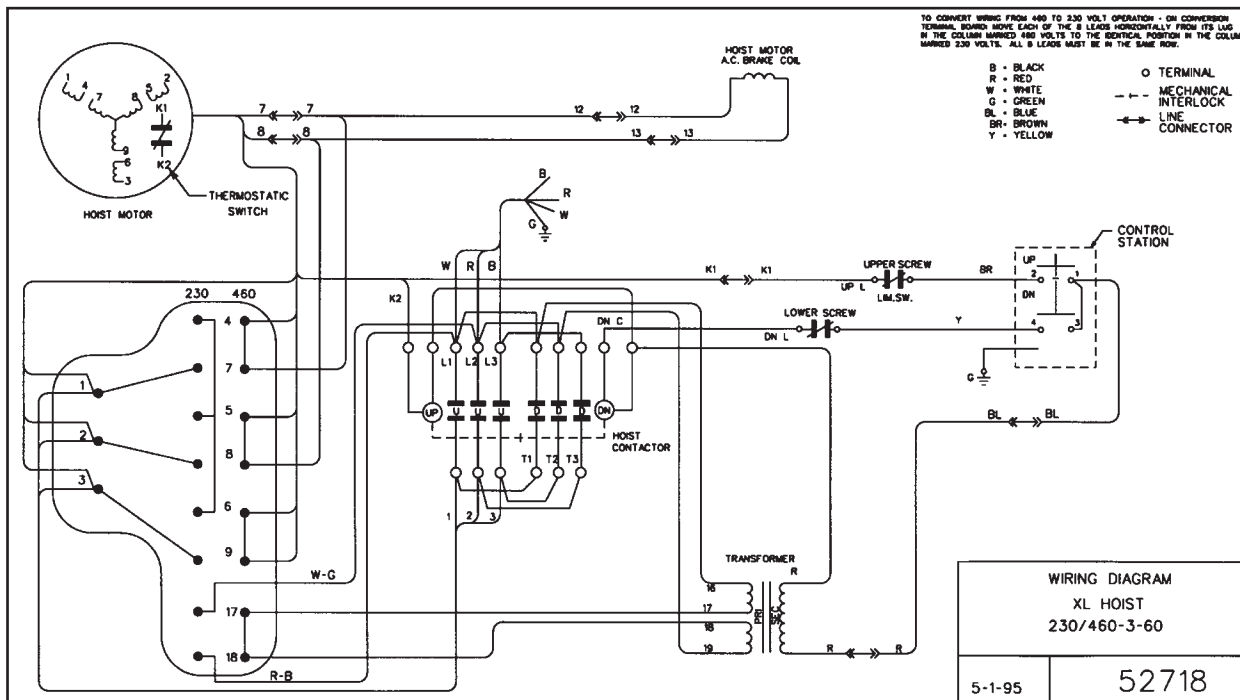

## SINGLE SPEED - HOIST ONLY

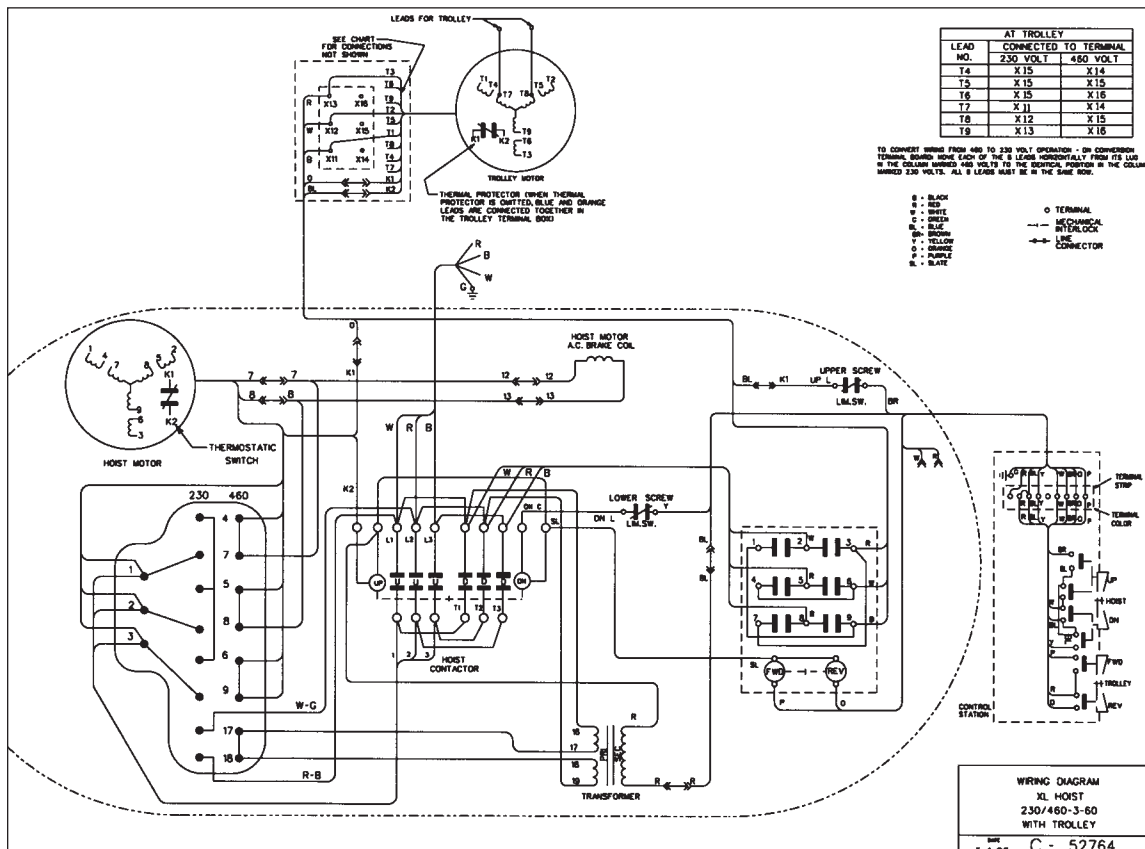

## 2 TON - SINGLE SPEED HOIST WITH TROLLEY



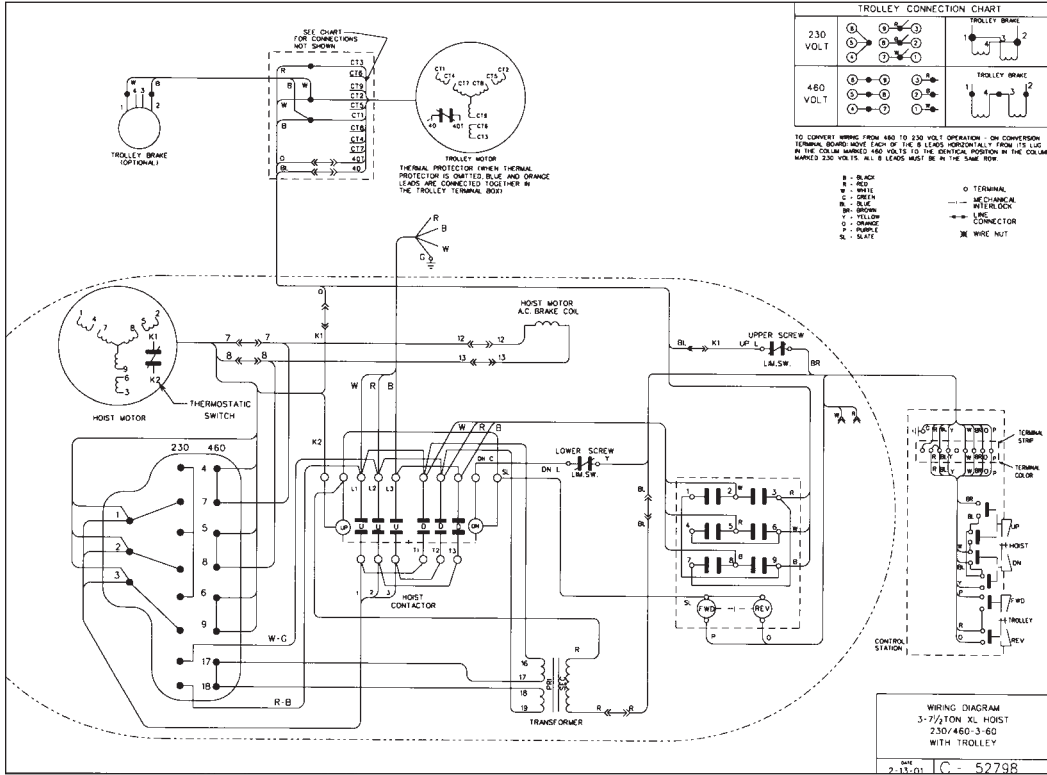

## 3-7½ TON - SINGLE SPEED HOIST WITH TROLLEY

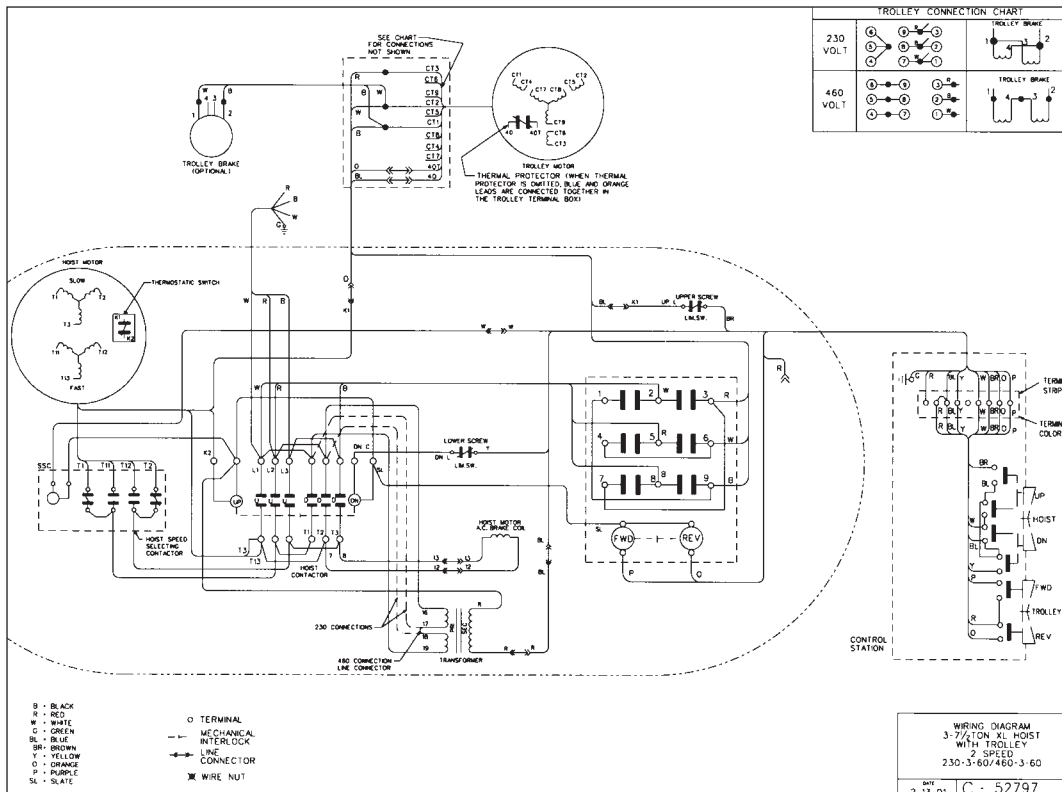

## 3-7½ TON 2 SPEED HOIST WITH SINGLE SPEED TROLLEY



## DISASSEMBLY

Refer to pages 30 through 40 for exploded view and parts list. The following are general guide lines for disassembling the XL Hoist. Prior to disassembly:

1. Operate the hoist in the "down" direction until the lower limit is reached. Remove the brake end cover (652-181) and disengage the limit switch guide plate from the traveling nuts (see page 15). Remove the chain container or remove the loose end screw (652-256) and washers (652-257 and 652-258).
2. Carefully run the chain out of the hoist. On 3 and 4 ton units, the chain will remain suspended from the dead end block (652-204).
3. Disconnect the hoist from the power supply system and Lockout/Tagout disconnecting means.

 <b>WARNING</b>
Working in or near exposed energized electrical equipment presents the danger of electrical shock.
<b>TO AVOID INJURY: DISCONNECT POWER AND LOCKOUT/TAGOUT DISCONNECTING MEANS BEFORE REMOVING COVER OR SERVICING THIS HOIST.</b>

4. Drain the oil from the hoist.
5. Remove the hoist from its support (hook suspended units) or remove the hoist and trolley from the beam. Remove the trolley from the hoist.

These guide lines cover the disassembly of the major mechanical components; not covered is the removal of obvious items such as hardware and seals. While disassembling the hoist, care should be taken so as to not damage the seals. Seals should be inspected for nicks or damage that could cause oil leaks. Damaged seals should be replaced prior to reassembly.

1. Remove brake end cover (652-181).
2. Remove the brake assembly (652-161) and brake hub (652-142).
3. Remove the entire limit switch assembly and the limit switch worm (652-146).
4. Remove the motor end cover (652-182) and the complete motor (652-162). Coupling (652-103) should remain on motor shaft.
5. On the 2, 3 and 4 ton units, remove chain plate (652-178). On the 5 and 6 ton units, remove the idler wheel housing (652-211) with idler wheel and bearings.
6. \*Remove the brake housing (652-108) and gasket (652-118).
7. Remove the drive shaft and pinion (652-112).
8. Remove the Protector (652-160).
9. \*Remove the intermediate plate (652-109) from the main housing (652-110) and remove gasket (652-118).
10. Remove the limit switch gear (652-149) from the limit switch input shaft (652-104) and remove the shaft from the intermediate plate.
11. Remove the second gear (652-159) from third reduction pinion and shaft (652-106) and remove the third reduction pinion and shaft from the main housing (652-110).
12. Remove the liftwheel gear (652-105) from the lift wheel (652-111).
13. Remove the motor housing (652-107) from the main housing (652-110).

14. Remove the chain stripper (652-114) and chain guide (652-113).
15. On the 3, 4, and 5 ton (Double Reeved) units, remove the dead end block (652-204) and chain.
16. Remove the liftwheel (652-111) from the main housing.

\*Slots are provided in intermediate plate (652-109) to aid in the removal of screws.

## REASSEMBLY

The reassembly of the hoist is, basically, the reverse of the above disassembly sequence. However, during reassembly:

1. If new seals are installed, make sure the lip of the seal is on the oil side.
2. Apply a light coat of gear oil to lips of all seals and surfaces of shafts that pass thru the seals.
3. Carefully slide the shafts through the seals.
4. The frame screws used to attach the motor and gear housings to the main frame should be tightened to a seating torque of 21 pound feet (28 NM).
5. Lubricate, especially the splines, as specified on page 14.
6. Make sure that "this side out" embossed on the liftwheel gear is visible when the gear is assembled to the liftwheel.
7. Place the load chain (with welds down and towards liftwheel. See illustration on page 27) over the liftwheel before attaching the motor housing to the main frame. After assembly reeve chain per page 27.
8. Follow instructions starting on page 4 when re-installing the unit.
9. After installation, test the unit as indicated on page 29.

## REMOVAL AND REPLACEMENT OF LOAD CHAIN

**USE ONLY STAR (H) GRADE LOAD CHAIN AND FACTORY REPLACEMENT PARTS. USE OF OTHER CHAIN AND PARTS MAY BE DANGEROUS AND VOIDS FACTORY WARRANTY.**

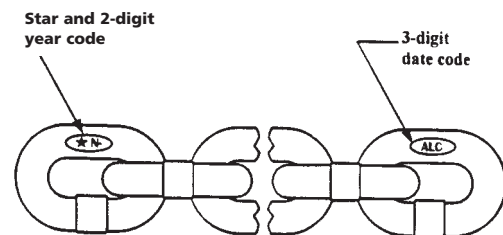

 <b>WARNING</b>
USE OF COMMERCIAL OR OTHER MANUFACTURERS' CHAIN AND PARTS TO REPAIR XL HOISTS MAY CAUSE LOAD LOSS.
<b>TO AVOID INJURY:</b>
Use only factory supplied replacement load chain and parts. Chain and parts may look alike, but factory chain and parts are made of specific material or processed to achieve specific properties.

Hoist load chain can be removed and installed using one of the following methods. Method 1 is recommended if only the load chain is replaced. Method 2 is recommended when the entire hoist is disassembled for repair and /or inspection.

#### METHOD 1

1. Disconnect the hoist from the power supply system.
2. Remove the motor end cover (652-182). On units with book suspension, remove the counterweight (652-219) prior to removing the motor cover.
3. Disengage the limit switch guide plate from the traveling nuts (see page 15).
4. Remove the chain container or remove the loose end of the chain from the hoist frame.
5. Using the procedures described on page 28 for cutting load chain, cut a portion out of the last loose end link to form a coupling link. The portion removed should be centered on the weld and be 1/2 inch (13mm) long. Remove burrs from cut edges.
6. Using the coupling link, attach the new chain to the old chain. Carefully check the welds on the new chain and make sure they are positioned the same as the old chain. The new chain must enter the hoist so that the welds are down and towards the lift wheel. See illustration below. Failure to properly position the chain will cause the chain to jam between the liftwheel and chain guide.
7. Re-energize power supply and carefully operate hoist in the "down" direction until approximately 6 feet (2 M) of the new chain is hanging free on the dead end side.
8. ON SINGLE REEVED UNITS, remove the hook block from the old chain, remove the coupling link, discard the old chain and attach the hook block to the new chain. ON DOUBLE REEVED UNITS, the hoist must be removed from the trolley before reeving the replacement load chain. For hook suspended units, the hook must be positioned so that the dead end bolt can be removed. If necessary, rotate hook approximately 45 degrees following the instructions on page 5. Now remove the chain plate and allow it and the dead end block spacer (652-253) to slide down the chain. Working through the cavity in the bottom of the hoist, hold the dead end block while loosening the dead end bolt. Remove the dead end block and remove the dead end pin. Remove the coupling link, pull the old chain out of the hook block and discard the old chain. Reeve the new load chain as described below. After reeving, mount trolley on hoist or reposition hook, if necessary, per installation instructions starting on page 4. ON TRIPLE REEVED UNITS, remove the dead end plate from the top of the hook block. Remove the dead end pin and remove the old chain from the dead end plate. Remove the coupling link, pull the old chain out of the hook block and idler sheave housing. Reeve the new load chain as described below.
9. Remount the chain container or reattach the loose end of the new chain to the hoist.
10. Reset upper and lower limit switches per page 15.

#### METHOD 2

1. Completely disassemble the hoist as described on page 26.
2. Prior to reassembly, inspect the liftwheel, chain guides and stripper for wear. If these parts are worn or damaged, they could cause premature wear of the chain. Replace worn or damaged parts.
3. Place chain on liftwheel with welds down and towards liftwheel as shown below. Welds must engage the relief machined in the bottom of the liftwheel pockets. If the chain is not properly placed

on the liftwheel, it will not be possible to install the chain guide. After making sure the chain is correctly installed on the liftwheel, continue to assemble the hoist.

4. On single reeved units, remove the hook block from the old chain and attach it to the new chain. On double and triple reeved units, reeve the new chain as described below.

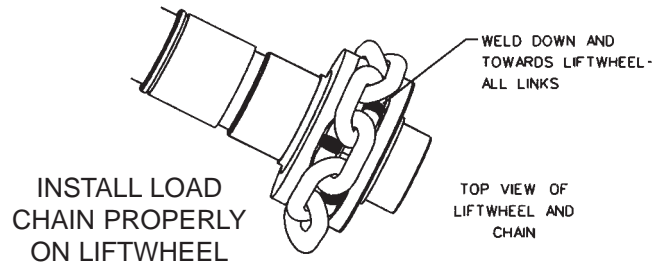

5. Install the unit following the installation instructions starting on page 4.
6. Remount the chain container or reattach the loose end of the new chain to the hoist frame.
7. Reset upper and lower limit switches per page 15.

#### WARNING

Improper installation (reeving) of load chain can result in dropped load.

#### TO AVOID INJURY:

Properly reeve load chain per the following instructions.

### REEVING LOAD CHAIN

#### 3, 4 AND 5 TON DOUBLE REEVED UNITS

The following instructions assume that the trolley has been removed from the hoist or the upper hook has been positioned to provide access to the dead end bolt and that there is 6 feet (2 m) of chain hanging free on the dead end side of the hoist. Based on these, reeve the load chain as follows:

1. Slide the suspension adapter into the hoist frame, if has moved out of position or if it was removed.
2. Install the dead end bolt.
3. Attach a soft wire to the end of the chain. Feed the wire around the hook block sheave. MAKING SURE THERE ARE NO TWISTS, pull the chain thru the hook block.
4. Feed the chain thru the square opening in the chain plate and then thru the dead end block spacer.
5. Attach the last link of chain to dead end block using the dead end pin.
6. MAKING SURE THERE ARE NO TWISTS IN THE CHAIN, slide the dead end block into the cavity in hoist frame. Turn the dead end bolt by hand to thread it into the dead end block. Then tighten dead end bolt to a seating torque of 120 pound feet (160 NM).
7. Slide the chain plate and spacer up the chain and attach the chain plate to the hoist frame.
8. Retrace the chain and make sure there are no twists. If there are twists, start over.

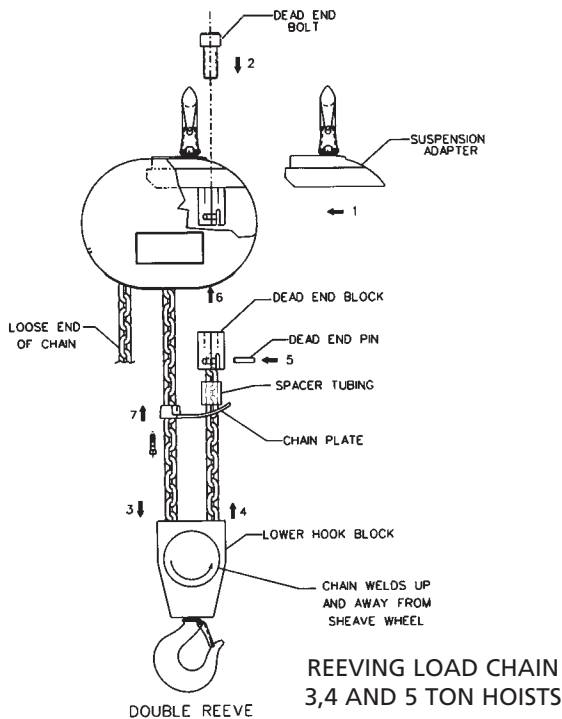

HOOK SUSPENSION SHOWN LUG SUSPENSION SIMILAR

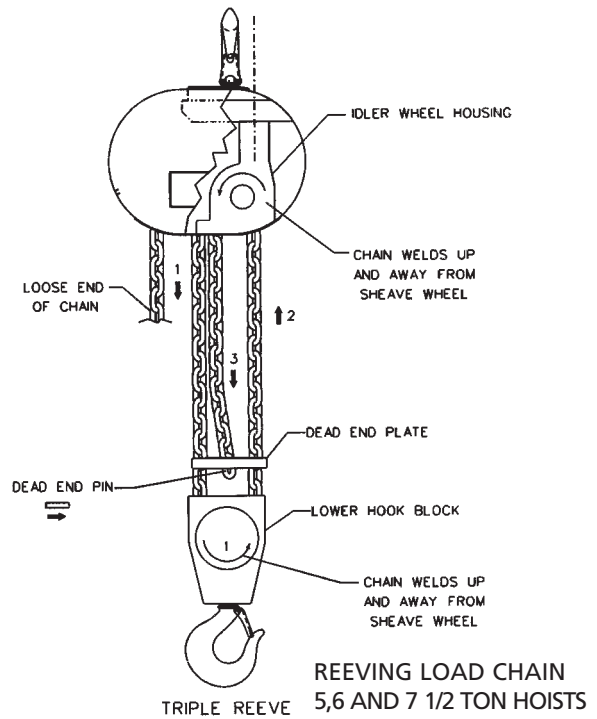

HOOK SUSPENSION SHOWN. LUG SUSPENSION SIMILAR

### 5, 6 AND 7 1/2 TON TRIPLE REEVED UNITS

The following instructions assume that the idler wheel housing assembly has been attached to the suspension adapter and hoist frame, there is 6 feet (2 M) of chain hanging free on the dead end side of the hoist and the hoist is suspended from the trolley or permanent support.

Based on these, reeve the load chain as follows:

1. Attach a soft wire to the end of the chain. Feed the wire around the hook block sheave. **MAKING SURE THERE ARE NO TWISTS IN THE CHAIN**, pull the chain thru the hook block.
2. Feed the soft wire into the outboard side of the idler wheel housing and around the idler wheel. **MAKING SURE THERE ARE NO TWISTS IN THE CHAIN**, pull the chain over the idler wheel.
3. Remove the wire from the end of the chain and route chain down to the hook block. **MAKING SURE THERE ARE NO TWISTS IN THE CHAIN**, insert the last link of the chain into the slot in the dead end plate. Secure the chain using the dead end pin and attach the dead end plate to top of hook block. Tighten the dead end plate screws to a seating torque of 120 pound feet (160 NM).
4. Retrace chain and make sure there are no twists. If there are twists, start over.

### CUTTING CHAINS

Hoistaloy<sup>®</sup> load chain is hardened and it is difficult to cut. The following methods are recommended when cutting a length of new chain from stock or cutting off worn chain. Always wear eye protection when cutting chain.

1. Use a grinder and nick the link on both sides (see below), then secure the link in a vise and break off with a hammer.

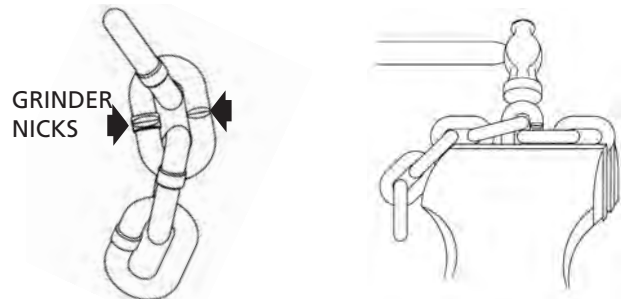

Cutting Chain by Nicking

2. Use a 7 inch ( 177 mm) minimum diameter by 1/8 inch ( 3.1 mm) thick abrasive wheel (or type recommended by wheel supplier) that will clear adjacent links.
3. Use a bolt cutter (See below) similar to the H.K. Porter No. 0590MTC with special cutter jaws for cutting hardened chain. Jaws should be 1 inch (25.4 mm) long.

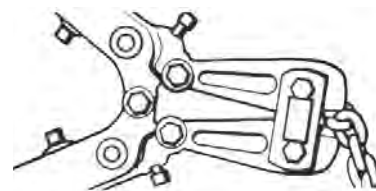

Cutting Chain with a Bolt Cutter

 <b>WARNING</b>
Cutting Chain Can Produce Flying Particles.
<p style="text-align: center;"><b>TO AVOID INJURY:</b></p> <ul style="list-style-type: none"> <li>• Wear Eye Protection</li> <li>• Provide A Shield Over Chain To Prevent Flying Objects</li> </ul>

**NOTE: WHEN ORDERING REPLACEMENT PARTS, IT IS RECOMMENDED THAT CONSIDERATION BE GIVEN TO THE NEED FOR ALSO ORDERING SUCH ITEMS AS GASKETS, FASTENERS, INSULATORS, SEALS, ETC. THESE ITEMS MAY BE DAMAGED OR LOST DURING DISASSEMBLY OR JUST UNFIT FOR FUTURE USE BECAUSE OF DETERIORATION FROM AGE OR SERVICE.**

**TESTING**

Before using, all altered, repaired or used hoists that have not been operated for the previous 12 months shall be tested by the user for proper operation. First, test the unit without a load and then with a light load of 50 pounds (23 kg) times the number of load supporting parts of load chain to be sure that the hoist operates properly and that the brake holds the load when control is released. Next test with a load of \*125% of rated capacity. In addition hoists in which load sustaining parts have been replaced should be tested with \*125% of rated capacity by or under the direction of an appointed person and written report prepared for record purposes. After this test, check that the Protector functions. If the Protector permits lifting a load in excess of 180% of rated load, it should be replaced.

**NOTE: For additional information on inspection and testing, refer to American National Standard ASME B30.16 "Overhead Hoists" obtainable from The American Society of Mechanical Engineers, 345 East 47th Street, New York, NY 10017 U.S.A.**

\*If the Protector prevents lifting of a load of 125% of rated capacity, reduce load to rated capacity.

 <b>WARNING</b>
Using "commercial" or other manufacturer's parts to repair the XL Hoists may cause load loss.
<p style="text-align: center;"><b>TO AVOID INJURY:</b></p> <p>Use only factory supplied replacement parts. Parts may look alike but factory original parts are made of specific materials or processed to achieve specific properties.</p>

**REPAIR PARTS**

**ORDERING INSTRUCTIONS**

The following information must accompany all correspondence and orders for replacement parts:

1. Hoist rated load from identification plate.
2. Serial number of the hoist stamped below identification plate.
3. Voltage, Phase, Hertz from identification plate.
4. Length of lift.
5. Key number part from parts list.
6. Number of parts required.
7. Part name from parts list.
8. Part number from the parts list.

If trolley replacement parts are ordered, also include the type and capacity of the trolley.

## XL Electric Chain Hoist Parts List

KEY NO.	NO. REQ'D	PART NAME	PART NUMBER
652-100	2	BRAKE HUB SNAP RING	35764
652-101	1	2ND GEAR SNAP RING	36763
652-102	1	2ND PINION SNAP RING	45766
652-103	1	MOTOR SHAFT COUPLING FOR: 2, 3, 4, 5 AND 6 TON 5 TON (DOUBLE REEVED) AND 7 1/2 TON (TRIPLE REEVED)	52018 52078
652-104	1	LIMIT SWITCH INPUT SHAFT	52019
652-105	1	LIFTWHEEL GEAR FOR: 2, 3, 4, 5 AND 6 TON 5 TON (DOUBLE REEVED) AND 7 1/2 TON (TRIPLE REEVED)	52021 52076
652-106	1	3RD REDUCTION PINION AND SHAFT FOR: 2, 3, 4, 5 AND 6 TON 5 TON (DOUBLE REEVED) AND 7 1/2 TON (TRIPLE REEVED)	52026 52075
652-107	1	MOTOR HOUSING ASSEMBLY (See note 1)	52631
652-108	1	BRAKE HOUSING ASSEMBLY (See note 2)	52632
652-109	1	INTERMEDIATE PLATE ASSEMBLY (See note 3)	52633
652-110	1	MAIN HOUSING ASSEMBLY (See note 4)	52630
652-111	1	LIFTWHEEL	52033
652-112	1	DRIVE SHAFT AND PINION FOR: 2, 3, 4, 5 AND 6 TON 5 TON (DOUBLE REEVED) AND 7 1/2 TON (TRIPLE REEVED)	52036 52079
652-113	1	CHAIN GUIDE	52041
652-114	1	CHAIN STRIPPER	52055
652-115	1	LIMIT SWITCH SHAFT ASSEMBLY	36623
652-116	1	MOUNTING BRACKET	52704
652-117	1	CONTACTOR MOUNTING PLATE	52706
652-118	2	MAIN HOUSING GASKET	52709
652-119	1	LIMIT SWITCH SPRING	52742
652-120	1	LIMIT SWITCH ASSEMBLY	52609
652-121	1	BREATHER	70726
652-122	2	DRIVE SHAFT SEAL	80401
652-123	2	DRIVE SHAFT BEARING	80402
652-124	1	2ND REDUCTION PINION BEARING - INBOARD	80403
652-125	1	2ND REDUCTION PINION BEARING - OUTBOARD	80404
652-126	1	3RD REDUCTION PINION BEARING - OUTBOARD	80408
652-127	3	CHAIN GUIDE PIN	80410
652-128	1	LIFTWHEEL BEARING - MOTOR END	80411
652-129	1	LIFTWHEEL SEAL - GEAR END	80412
652-130	1	*BRAKE COIL: (See note 5) 208-240 VOLT 380-480 VOLT 550-575 VOLT	68877 68878 68879
652-131	2	BRAKE FRICTION DISC	70652
652-132	1	LIFTWHEEL SEAL - INBOARD	80415
652-133	1	LIFTWHEEL GEAR SNAP RING	80416
652-134	1	LIMIT SWITCH INPUT SHAFT SEAL	80417
652-135	1	TRANSFORMER : 208-240/380-480 VOLT PRIMARY, 115 VOLT SECONDARY 208-240/380-480 VOLT PRIMARY, 48 VOLT SECONDARY	68810 70793
CON'T.			

KEY NO.	NO. REQ'D	PART NAME	PART NUMBER
652-135	1	208-240/380-480 VOLT PRIMARY, 24 VOLT SECONDARY 550-575 VOLT PRIMARY, 115 VOLT SECONDARY	68811 68786
652-136	1	HOIST REVERSING CONTACTOR WITH : 115 VOLT COILS 48 VOLT COILS 24 VOLT COILS	52749 52751 52750
652-137	1	SPEED SELECTING CONTACTOR WITH : 115 VOLT COIL 48 VOLT COIL 24 VOLT COIL	70805 70806 70781
652-138	1	TROLLEY REVERSING CONTACTOR WITH : 115 VOLT COILS 48 VOLT COILS 24 VOLT COILS	28835 28846 28837
652-139	--	LINE CONNECTOR-SPECIFY NO REQ'D.	982158
652-140	4	MOTOR BOLT	80429
652-141	2	LIMIT SWITCH INPUT SHAFT BEARING	88437
652-142	1	BRAKE HUB	68367
652-143	1	LIFTWHEEL BEARING - GEAR END	80413
652-144	1	3RD REDUCTION PINION BEARING - INBOARD	88500
652-145	15	FRAME SCREW	987289
652-146	1	LIMIT SWITCH WORM	35756
652-147	1	LIMIT SWITCH WORM PIN	983766
652-148	1	LIMIT SWITCH GEAR PIN	983768
652-149	1	LIMIT SWITCH GEAR FOR : 6, 9, 10, 15.2, 18, 30, 2/6, 3/9 AND 6/18 FPM 8, 12, 24, 8/2.7, 4/12 AND 8/24 FPM	52720 52713
652-150	2	FRAME PLUG (1")	989074
652-151	1	GROUND SCREW	982686
652-152	2	LIMIT SWITCH SHAFT BEARING	35751
652-153	2	LIM. SW. SHAFT BEARING SCREW	983643
652-154	1	LIMIT SWITCH GUIDE PLATE	28714
652-155	2	LIMIT SWITCH GUIDE PLATE SCREW	983614
652-156	2	FRAME PLUG (3/4")	989055
652-157	1	POWER CORD	51108
652-158	1	POWER CORD CONNECTOR	983979
652-159	1	2ND GEAR FOR : 6, 9, 10, 15.2, 18, 30, 2/6, 3/9 AND 6/18 FPM 8, 12, 24, 2.7/8, 4/12, AND 8/24 FPM	52043 52024
652-160	1	PROTECTOR ASSEMBLY FOR : CAPACITY                      SPEED (TONS)                              (FPM) 2                                      18 AND 6/18 2                                      24 AND 8/24 2                                      30 3                                      9 AND 3/9 3                                      12 AND 4/12 3                                      15 AND 5/15 4                                      9 AND 3/9 4                                      12 AND 4/12 4                                      15 5                                      6 AND 2/6 5                                      8 AND 2.7/8 5                                      9 AND 9/3 5                                      12 5                                      15.2	52613 52614 52626 52628 52613 52665 52613 52614 52626 52627 52613 52665 52626 52661
CONT			

KEY NO.	NO. REQ'D	PART NAME	PART NUMBER
652-160	1	PROTECTOR ASSEMBLY FOR: Con't:	
		6 6 AND 2/6	52613
		6 8 AND 2.7/8	52614
		6 10	52626
		7 1/2 6 AND 2/6	52665
7 1/2 10	52661		
652-161	1	ELECTRIC BRAKE COMPLETE:	
		208-240/380-480 VOLT, ONE SPEED	52606
		208-240 VOLT, TWO SPEED	52606
		380-480 VOLT, TWO SPEED	52611
		550-575 VOLT, SINGLE AND TWO SPEED	52612
		FOR: 5 TON (DOUBLE REEVED) AND 7 1/2 TON (TRIPLE REEVED) 208-240/380-480 VOLT, SINGLE SPEED	52660
652-162	1	MOTOR (ROTOR WITH BEARINGS, STATOR AND END BELL) FOR :	
		208-240/380-480 VOLT, SINGLE SPEED	52710
		208-240 VOLT, TWO SPEED	52711
		380-480 VOLT, TWO SPEED	52712
		550-575 VOLT, SINGLE SPEED	52730
		550-575 VOLT, TWO SPEED	52754
		FOR: 5 TON (DOUBLE REEVED) AND 7 1/2 TON (TRIPLE REEVED) 208-240/380-480 VOLT, SINGLE SPEED	52812
652-163	--	LOAD CHAIN - SPECIFY LENGTH REQ'D	85885
652-164	1	WIRING HARNESS FOR :	
		SINGLE SPEED	51109
		TWO SPEED	51110
652-165	2	CONTACTOR MOUNTING PLATE SCREW	983747
652-166	1	CONVERSION T.B. BRACKET	52705
652-167	2	BRACKET ATTACHING SCREW	982683
652-168	1	CONVERSION TERMINAL BOARD	28828
652-169	1	CONVERSION T.B. INSULATOR	27776
652-170	3	CONVERSION T.B. SCREW	987847
652-171	3	CONVERSION T.B. SCREW L.W.	987873
652-172	-	JUMPERS	-
		FOR SINGLE SPEED: 3-51111, 4-51112, AND 3-51113 JUMPERS REQ'D. FOR TWO SPEED: 4-51111, 6-51112, AND 2-51114 JUMPERS REQ'D.	
652-173	3	TRANSFORMER SCREW	987859
652-174	3	TRANSFORMER SCREW L.W.	987873
652-175	1	LOWER HOOK WITH LATCH --- LATCH TYPE :	
		2 TON	35612
		3, 4, 5, 6 AND 7 1/2 TON	52651
		LOWER HOOK --- LATCHLOK TYPE :	
		2-TON	36681
3, 4, 5 AND 6 TON	52625		
3-6 TON LOWER LATCHLOK KIT	5264		
652-176	1	HALF LINK	52017
652-177	2	HOOK BLOCK :	
		2 TON	52025
		3 AND 4 TON	52049
		5, 6 AND 7 1/2 TON	52069
652-178	1	CHAIN PLATE :	
		2 TON	52046
		3 AND 4 TON	52048
652-179	-	HOOK BLOCK SCREW :	
		2 TON - 4 REQ'D.	982369
		3 AND 4 TON - 4 REQ'D.	80423
		5, 6 AND 7 1/2 TON - 2 REQ'D.	80423
652-180	2	CHAIN PLATE OR IDLER HOUSING SCREW	987288

KEY NO.	NO. REQ'D	PART NAME	PART NUMBER
652-181	1	BRAKE END COVER	52028
652-182	1	MOTOR END COVER	52031
652-183	1	IDENTIFICATION PLATE:	
		LODESTAR XL	70728
		BUDGIT XL	70736
652-184	4	BRAKE END COVER SCREW	80409
652-185	4	I.D. PLATE DRIVE SCREW	988271
652-186	2	WARNING LABEL, ELECTRICAL	24842
652-187	1	LIFTWHEEL GEAR BEARING	80414
652-188	1	2ND REDUCTION PINION FOR :	
		6, 9, 10, 15.2, 18, 30, 2/6, 3/9 AND 6/18 FPM	52044
		8, 12, 24, 2.7/8, 4/12 AND 8/24 FPM	52023
652-189	1	CAPACITY LABEL FOR :	
		2 TON	52714
		3 TON	52724
		4 TON	52716
		5 TON	52726
		6 TON	52728
		7 1/2 TON	52757
652-190	1	WARNING LABEL FOR :	
		2 TON	52715
		3 TON	52725
		4 TON	52717
		5 TON	52727
		6 TON	52729
		7 1/2 TON	52785
652-191	1	COIL RETAINER STRAP	35704
652-192	1	BRAKE BASE PLATE	52607
652-193	1	BRAKE FIELD PLATE	59634
652-194	3	BRAKE SPRING FOR:	
		2, 3, 4, 5 AND 6 TON	68818
		5 TON (DOUBLE REEVED) AND 7 1/2 TON (TRIPLE REEVED)	52811
652-195	1	BRAKE INTERMEDIATE PLATE	68820
652-196	1	BRAKE ARMATURE	70657
652-197	3	BRAKE NUT	982448
652-198	4	MOTOR COVER SCREW	80409
652-199	2	SPEED SELECTOR SCREW	982706
652-200	1	HOOK NUT OR COLLAR FOR :	
		2 TON	35369
		3, 4, 5, 6 AND 7 1/2 TON	52047
652-201	1	HOOK NUT OR COLLAR PIN FOR :	
		2 TON	45946
		3, 4, 5, 6 AND 7 1/2 TON	80418
652-202	1	LOWER HOOK THRUST BEARING FOR :	
		2 TON	88505
		3, 4, 5, 6 AND 7 1/2 TON	80421
652-203	1	SHEAVE WHEEL	52050
652-204	1	DEAD END BLOCK	52051
652-205	1	DEAD END PIN	52057
652-206	2	SHEAVE WHEEL BEARING	80422
652-207	1	DEAD END BOLT	80424
		3, 4, 5, 6 AND 7 1/2 TON	
652-208	2	HOOK BLOCK CAPACITY LABEL FOR :	
		3 TON	52738
		4 TON	52739
		5 TON	52740
		6 TON	52741
		7 1/2 TON	52786
652-209	4	CAPACITY LABEL DRIVE SCREW	988271
652-210	1	DEAD END PLATE	52068
652-211	1	IDLER WHEEL HOUSING	52053

KEY NO.	NO. REQ'D	PART NAME	PART NUMBER
652-212	1	IDLER WHEEL	52054
652-213	1	ANCHOR PIN	52058
652-214	2	IDLER WHEEL BEARING	80425
652-215	6	DEAD END PLATE SCREW	52074
652-216	1	LATCH KIT FOR: 2 TON 3, 4, 5, 6 AND 7½ TON	45663 52701
652-217	1	SUSPENSION ADAPTER FOR : 2 TON 3, 4, 5 AND 6 TON	52022 52035
652-218	1	UPPER HOOK NUT FOR : 2 TON 3, 4, 5 AND 6 TON	52045 52047
652-219	1	COUNTERWEIGHT	52061
652-220	1	UPPER HOOK, LATCH TYPE, FOR : 2 TON 3, 4, 5 AND 6 TON UPPER HOOK, LATCHLOK TYPE FOR : 2 TON 3, 4, 5 AND 6 TON	52608 52651 52624 52625
652-221	1	HOOK NUT PIN	80418
652-222	1	ANTI-ROTATION PIN FOR : 2 TON 3, 4, 5 AND 6 TON	80419 80420
652-223	2	COUNTERWEIGHT SCREW	80428
652-224	1	SUSPENSION SCREW ( 2 TON ONLY)	987208
652-225	1	ANTI-ROTATION PLATE	52708
652-226	1	ANTI-ROTATION PLATE SCREW	982371
652-227	1	UPPER HOOK SUSPENSION, LATCH TYPE COMPLETE (SEE NOTE 6) : 2 TON 3, 4, 5 AND 6 TON	5254 5255
652-228	2	LIMIT SWITCH BRACKET SCREW	982708
652-229	2	LIMIT SWITCH BRACKET SCREW L.W.	982226
652-230	1	LIMIT SWITCH BRACKET	35032
652-231	1	LIM. SW. ASSEMBLY ATTACH. SCREW	983614
652-232	1	DRAIN PLUG	989050
652-233	1	2ND REDUCTION PINION SNAP RING FOR: 6, 9, 10, 15.2, 18, 30, 2/6, 3/9, AND 6/18 FPM UNITS ONLY.	45766

- Notes:  
1. Includes 652-128  
2. Includes 652-122, 652-123, 652-125, 652-134, and 652-141.  
3. Includes 652-122, 652-123, 652-124, 652-126, 652-132, 652-141, and 652-187.  
4. Includes Dowel Pins, 652-129, 652-143, and 652-144.  
5. Dual Voltage (208-240/440-480, 220/380 and 220/415) units use 230 volt brake coil part number 68877.  
6. If complete Latchlok Type Hook Suspension is Required, Contact Factory.

KEY NO.	NO. REQ'D	PART NAME	PART NUMBER
652-234	1	TROLLEY CONTACTOR BRACKET	52722
652-235	1	TROLLEY SPEED SELECTOR INSULATOR	52723
652-236	1	TROLLEY SPEED SELECTOR WITH: 115 VOLT COIL 48 VOLT 24 VOLT COIL	28806 28848 28829
652-237	2	TRO. CONTACTOR BRACKET SCREW	25862
652-238	2	TRO. SPEED SELECTOR SCREW	25859
652-239	2	TROLLEY CONTACTOR SCREW	25866
652-240	1	TERMINAL INSULATOR	35881
652-241	--	TROLLEY CONTACTOR JUMPERS: 3-51661 JUMPER AND 1-51699 JUMPER	--
652-242	3	TROLLEY CONTACTOR TO SPEED SELECTOR JUMPER	51661
652-243	1	HOIST CONTACTOR TO TROLLEY CONTACTOR HARNESS	51118
652-244	4	BRAKE ATTACHING SCREW	946801
652-245	2	LODESTAR XL LABEL	52760
652-245	2	BUDGIT XL LABEL	52782
652-246	1	CONTROL CORD ATTACHING SCREW	982688
652-247	1	CONTROL CORD ATTACH. SCREW L. W.	982226
652-248	1	CONTROL CORD ATTACH. SCREW WASHER	927835
652-249	1	WARNING TAG	81704
652-250	1	CONTROL CORD ASSEMBLY FOR: SINGLE SPEED HOIST WITH 10 FT. LIFT TWO SPEED HOIST WITH 10 FT. LIFT SINGLE OR TWO SPEED HOIST WITH 10 FT. LIFT AND MOTOR DRIVEN TROLLEY (FOR OTHER LIFTS CONTACT CM)	51400 51115 51119
652-251	2	END COVER GASKET (WEATHER PROOF UNITS ONLY)	52759
652-252	2	CONTACTOR MOUNTING SCREW	982686
652-253	1	DEAD END BLOCK SPACER	52064
652-254	1	CONV. T.B. LABEL-LONG	52721
652-255	1	TROLLEY CORD HOLE PLUG	989052
652-256	1	LOOSE END SCREW	982667
652-257	1	LOOSE END SCREW WASHER	987898
652-258	1	LOOSE END SCREW WASHER	45915
652-259	1	CONV. T.B. LABEL-SHORT	52762
652-260	1	CONTROL GROMMET O-RING	52778
652-261	1	CONTROL GROMMET	52777
652-262	1	ROTOR BEARING -OUTBOARD	83692
652-263	1	ROTOR BEARING -INBOARD	83689

Part number for Packaged Lubricants Used in the XL Electric Chain Hoists (Refer to page 15 for Lubrication Instructions)		
Lubricant Usage	Type of Lubricant	Part Numbers and Packaged Quantity of Lubricants
Hoist Gears	Grease Oils (Amoco 85W-140)	52776 for 1 Gal. Can
Splines	*Grease	EP Type Grease - Obtain Locally
Load Chain	Oil	28608 for 1 Pint Can 28619 for 1 Gal. Can
Limit Switch Shaft Threads	*Oil	"3 in 1" or Light Machining Oil - Obtain Locally
Lower Hook Thrust Bearing	*Oil	Heavy Maching Oil Obtain Locally
Trolley Trackwheel Bearings and Gears	Grease (Novatex #2)	28632 for 4 lb. Can 28610 for 1 lb. Can
Trolley Gears	Grease (Novatex #1)	28613 for 4 lb. Can 28612 for 1 lb. Can

\*These lubricants are not furnished by in Packaged Quantities.  
When ordering lubricants, specify the type of lubricant, part number and packaged quantity required.  
Touch-up Paints for Lodestar XL Electric Chain Hoists and 2 Ton Trolley Order: (1) case (12-12 oz. Aerosol Cans) of Orange Touch-up paint Part Number 84190.

Touch-up Paints for 3-7½ Ton Trolleys order: (1) case (12-12 oz. Aerosol Cans) of Black Touch-up Paint Part Number 84189.  
Touch-up paint is only available in case quantities.

Note: When painting Hoists or Trolley, also order warning labels, identification labels, etc. that may be coating during painting.

# 3 THRU 7½ TON MOTOR AND GEAR BOX ASSEMBLY

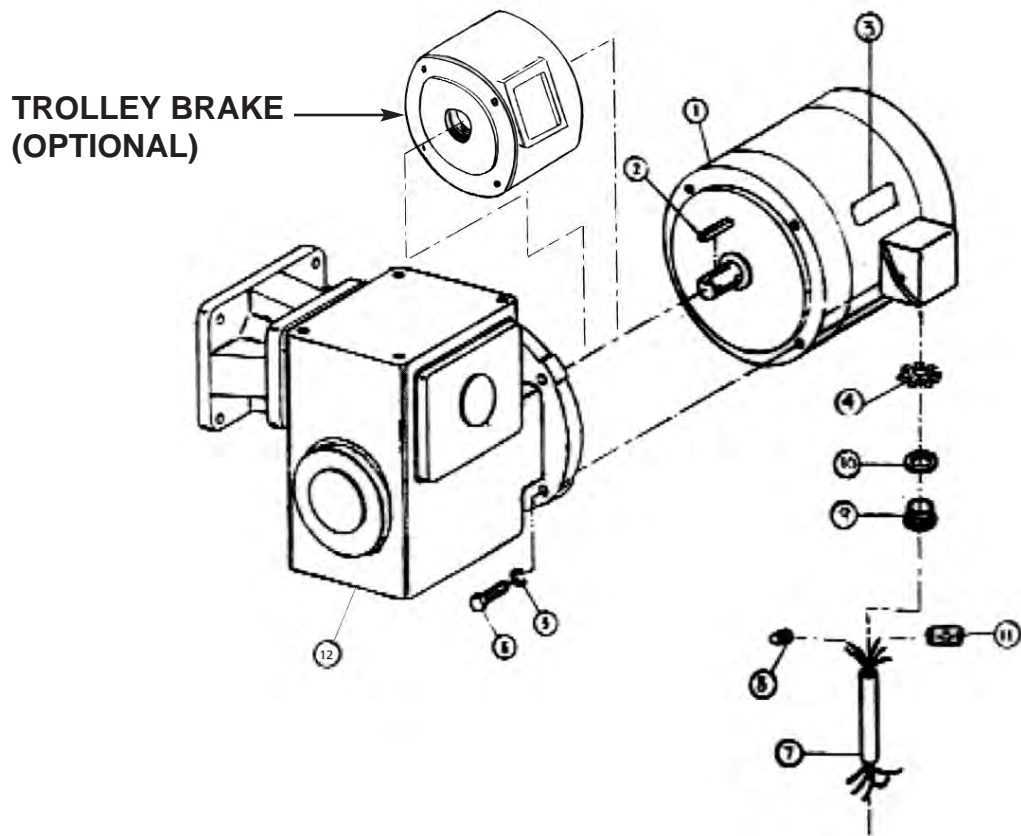

\*SEE PAGE 47 FOR TROLLEY BRAKE ASSEMBLY

REF. NO.	NO. REQ'D	PART DESCRIPTION	PART NUMBER
			3-7 1/2 TON
	1	MOTOR & GEARBOX ASS'Y (LESS POWER CORD)	BET-3000
1	1	MOTOR (INCLUDES REF. NO.2	BET-3001
2	1	MOTOR KEY (3/16 X 3/16 X 1 1/4")	BET-3002
	1	GEAR BOX ASS'Y - COMPLETE	BET-3003
3	1	ELECTRICAL WARNING LABEL	24842
4	1	POWER CONNECTOR LOCKNUT	989771
5	4	LOCKWASHER	BET-3006
6	4	HEX HEAD BOLT (3/8-16 X 7/8)	BET-3007
7	1	POWER CORD	51120
8	SPECIFY QTY.	WIRE NUT	983812
9	1	POWER CORD CONNECTOR	89926
10	1	WEATHERPROOF O-RING	983967
11	SPECIFY QTY.	LINE CONNECTOR	982158



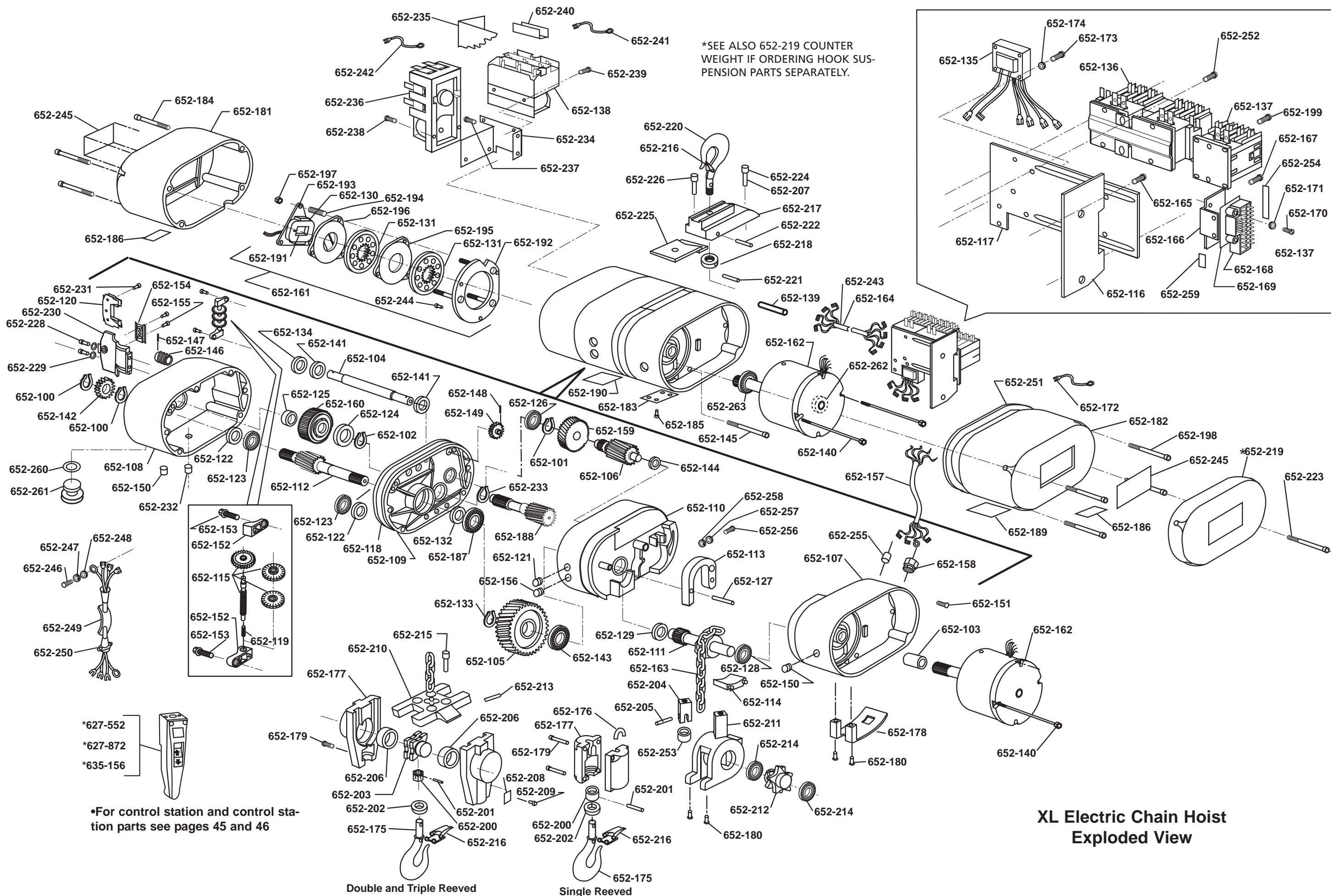

**XL Electric Chain Hoist  
Exploded View**

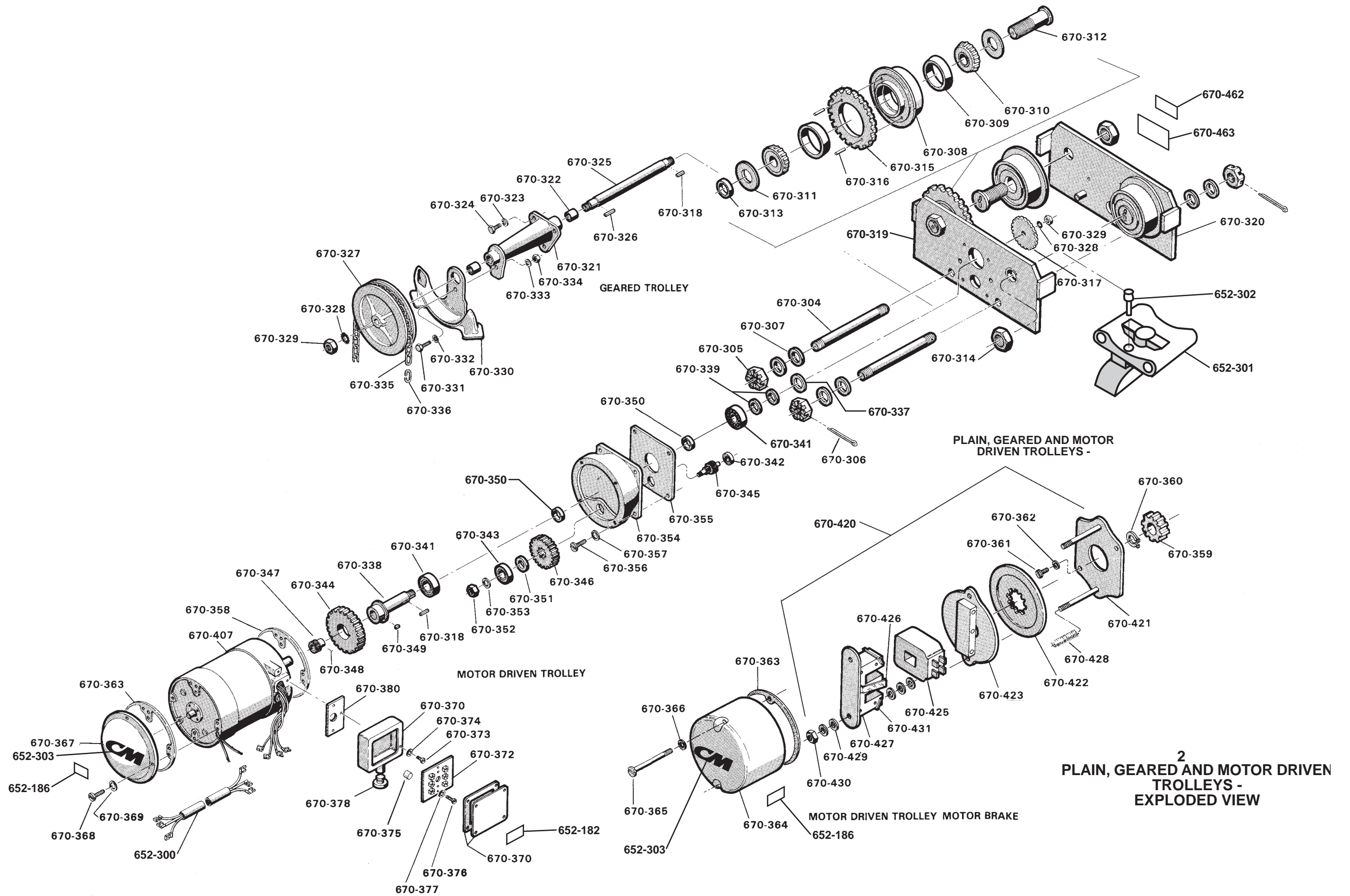

## 2 TON Plain, Geared and Motor Driven Trolleys Parts List.

Key No.	No. Req'd	Part Name	Part Number
			2 TON
652-186	2	WARNING LABEL, ELECTRICAL	24842
652-300	1	TROLLEY POWER CORD	51117
652-301	1	HOIST SUSPENSION ADAPTER	52059
652-302	1	SUSPENSION ADAPTER SCREW / DEAD END BOLT	987208
652-303	1	"CM" LABEL	25779
670-304	2	SUSPENSION BOLT FOR : 3.25" TO 5.50" FLANGE (82.6 to 139.7 mm)	58503
		5.51" TO 7.63" FLANGE (139.9 to 193.8 mm)	59350
670-305	4	SUSPENSION BOLT NUT	958818
670-306	4	SUSPENSION BOLT NUT COTTER PIN	988368
670-307	—	SPACER WASHER - SPECIFY NO. REQ'D.	958726
670-308	4	TRACKWHEEL WITH BEARING CUP : CROWNED TREAD	C437
670-309	8	TRACKWHEEL BEARING CUP	88521
670-310	8	TRACKWHEEL BEARING CONE	88525
670-311	8	TRACKWHEEL BEARING SHIELD	68918
670-312	4	TRACKWHEEL STUD	58459
670-313	4	TRACKWHEEL STUD COLLAR	58484
670-314	4	TRACKWHEEL STUD NUT	982613
670-315	2	TRACKWHEEL GEAR FOR : GEARED TROLLEY	58548
		35 AND 65 FPM TROLLEYS (10.7 and 19.8 MPM)	58548
		50 FPM TROLLEYS (15.2 MPM)	58548
		100 FPM TROLLEY (30.4 MPM)	58548
		35/65 FPM TROLLEYS (10.7/ 19.8 MPM)	58548
		25/50 FPM TROLLEYS (7.6/ 15.2 MPM)	58548
		50/100 FPM TROLLEY(15.2/ 30.4 MPM)	58548
670-316	4	TRACKWHEEL GEAR PIN	983503
670-317	1	TRACKWHEEL GEAR PINION FOR: GEARED TROLLEY	58505
		35 AND 65 FPM TROLLEYS (10.7 and 19.8 MPM)	58505
		50 FPM TROLLEYS (15.2 MPM)	58505
		100 FPM TROLLEY (30.4 MPM)	58505
		35/65 FPM TROLLEYS (10.7/ 19.8 MPM)	58505
		25/50 FPM TROLLEYS (7.6/ 15.2 MPM)	58487
		50/100 FPM TROLLEYS (15.2/ 30.4 MPM)	58505
670-318	1	TRACKWHEEL PINION KEY	85546
670-319	1	GEARED SIDE FRAME FOR : 3.25" TO 5.50" FLANGE (82.6 to 139.7 mm)	59615
		5.51" TO 7.63" FLANGE (139.9 to 193.8 mm)	58618

KEY NO.	NO. REQ'D	PART NAME	PART NUMBER
			2 TON
670-320	2 REQ'D. FOR PLAIN TROLLEYS	PLAIN SIDE FRAME FOR: 3.25" TO 5.50" FLANGE (82.6 to 139.7 mm.)	59614
		5.51" TO 7.63" FLANGE (139.9 to 193.8 mm.)	58617
	1 REQ'D. FOR GEARED AND MOTOR DRIVEN TROLLEYS		
670-321	1	HANDWHEEL BRACKET WITH BUSHINGS	59616
670-322	2	HANDWHEEL BUSHING	58727
670-323	3	HANDWHEEL BRACKET SCREW L.W.	945853
670-324	3	HANDWHEEL BRACKET SCREW	987061
670-325	1	HANDWHEEL SHAFT	58504
670-326	1	HANDWHEEL KEY	59967
670-327	1	HANDWHEEL	33143
670-328	1 OR 2	TRACKWHEEL PINION OR HANDWHEEL SHAFT NUT L.W.	986270
670-329	1 OR 2	TRACKWHEEL PINION OR HANDWHEEL SHAFT NUT	988095
670-330	1	HANDCHAIN GUIDE	58152
670-331	1	CHAIN GUIDE SCREW	987065
670-332	1	CHAIN GUIDE SCREW WASHER	986224
670-333	1	CHAIN GUIDE SCREW L.W.	945853
670-334	1	CHAIN GUIDE SCREW NUT	945822
670-335	—	HAND CHAIN - SPECIFY LENGTH REQ'D.	619022
670-336	1	HAND CHAIN CONNECTING LINK	945491
670-337	—	TRACKWHEEL PINION SPACER WASHER-SPECIFY NO. REQ'D.	987963
670-338	1	TRACKWHEEL PINION SHAFT	58450
670-339	1 or 2	TRACKWHEEL PINION SPACER -- SPECIFY NO. REQ'D.	58456
670-341	2	PINION SHAFT BEARING	88438
670-342	1	INTERMEDIATE SHAFT BEARING -- SIDE FRAME END	88437
670-343	1	INTERMEDIATE SHAFT BEARING --MOTOR END	88436
670-344	1	DRIVEN GEAR	58451
670-345	1	INTERMEDIATE PINION	58452
670-346	1	INTERMEDIATE GEAR FOR : 35 AND 65 FPM TROLLEYS (10.7 and 19.8 MPM)	58453
		50 FPM TROLLEYS (15.2 MPM)	58407
		100 FPM TROLLEY (30.4 MPM)	58407
		35/65 FPM TROLLEYS (10.7/ 19.8 MPM)	58453
		25/50 FPM TROLLEYS (7.6/ 15.2 MPM)	58453
Con't.		50/100 FPM TROLLEY (15.2/ 30.4 MPM)	58453

KEY NO.	NO. REQ'D	PART NAME	PART NUMBER
			2 TON
670-347	1	MOTOR PINION FOR :	
		35 AND 65 FPM TROLLEYS (10.7 and 19.8 MPM)	54356
		50 FPM TROLLEYS (15.2 MPM)	58406
		100 FPM TROLLEYS (30.4 MPM)	58406
		35/65 FPM TROLLEYS (10.7/ 19.8 MPM)	54356
		25/50 FPM TROLLEYS (7.6/ 15.2 MPM)	54356
670-348	1	MOTOR PINION PIN	988263
670-349	1	DRIVEN GEAR KEY	989096
670-350	2	PINION BEARING SPACER	58456
670-351	1	INTERMEDIATE BEARING SPACER	58728
670-352	1	INTERMEDIATE PINION NUT	988146
670-353	1	INTERMEDIATE PINION NUT L.W.	986266
670-354	1	GEAR HOUSING	70064
670-355	1	GEAR HOUSING GASKET	58729
670-356	4	GEAR HOUSING SCREW	987019
670-357	4	GEAR HOUSING SCREW L.W.	945851
670-358	1	MOTOR END BELL GASKET -	58730
670-359	1	BRAKE HUB	59363
670-360	1	BRAKE HUB SNAP RING	27766
670-361	2	BRAKE ATTACHING SCREW	982708
670-362	2	BRAKE ATTACHING SCREW L.W.	982226
670-363	2	MOTOR COVER GASKET - WEATHERPROOF UNITS ONLY	68756
670-364	1	BRAKE COVER	58161
670-365	3	BRAKE COVER SCREW	968752
670-366	3	BRAKE COVER SCREW L.W. FOR :	
		NON-WEATHERPROOF UNITS	940802
		WEATHERPROOF UNITS	982251
670-367	1	MOTOR END COVER	68751
670-368	3	MOTOR END COVER SCREW	982717
670-369	3	MOTOR END COVER SCREW L.W. FOR :	
		NON-WEATHER PROOF UNITS	982226
		WEATHERPROOF UNITS	982251
670-370	1	TERMINAL BOX AND COVER	58120
670-372	1	TERMINAL BOARD	68837
670-373	1	TERMINAL BOX SCREW	927930
670-374	1	TERMINAL BOX SCREW L.W.	982226
670-375	2	TERMINAL BOARD SPACER	68776
670-376	2	TERMINAL BOX AND BOARD SCREW	982695
670-377	2	TERMINAL BOX AND BOARD SCREW L.W.	986290

KEY NO.	NO. REQ'D	PART NAME	PART NUMBER
			2 TON
670-378	1	POWER CORD CONNECTOR	89926
670-380	1	TERMINAL BOX GASKET	59991
670-407	1	TROLLEY MOTOR (REFER TO MOTOR NAMEPLATE) :	
		.5 HP, 600 RPM, 230/460 V.	57766
		.5 HP, 600 RPM, 575 V.	57782
		.5 HP, 1200 RPM, 230/460 V.	68916
		.5 HP, 1200 RPM, 575 V.	57771
		.25/.5 HP, 600/1200 RPM, 230 V.	57273
		.25/.5 HP, 600/1200 RPM, 460 V.	57274
		.25/.5 HP, 900/1800 RPM, 230 V.	57778
		.25/.5 HP, 900/1800 RPM, 460 V.	57779
		.25/.5 HP, 900/1800 RPM, 575 V.	57783
670-420	1	TROLLEY BRAKE (INCLUDES 670-421, 670-422, 670-423, AND 670-425 THROUGH 670-431) FOR :	
		230/460 V. SINGLE SPEED AND 230 V. TWO SPEED TROLLEYS	59692
		460 V. TWO SPEED TROLLEYS	59694
		575 V. SINGLE AND TWO SPEED TROLLEYS	59693
670-421	1	BRAKE BASE PLATE	28668
670-422	1	FRICTION DISC	27677
670-423	1	BRAKE ARMATURE	28678
670-425	1	BRAKE COIL FOR:	
		230/460V. SINGLE SPEED AND 230 V. TWO SPEED TROLLEYS	51518
		460 V. TWO SPEED TROLLEYS	51519
		575 V. SINGLE AND TWO SPEED TROLLEYS	51520
670-426	1	BRAKE COIL RETAINER STRAP	57753
670-427	1	BRAKE FIELD	28677
670-428	2	BRAKE SPRING	68750
670-429	10	BRAKE SPACER WASHER	954807
670-430	2	BRAKE STUD NUT	945840
670-431	2	SHADING COIL	54831
670-462	1	WARNING LABEL	936984
670-463	1	CAPACITY LABEL	957928

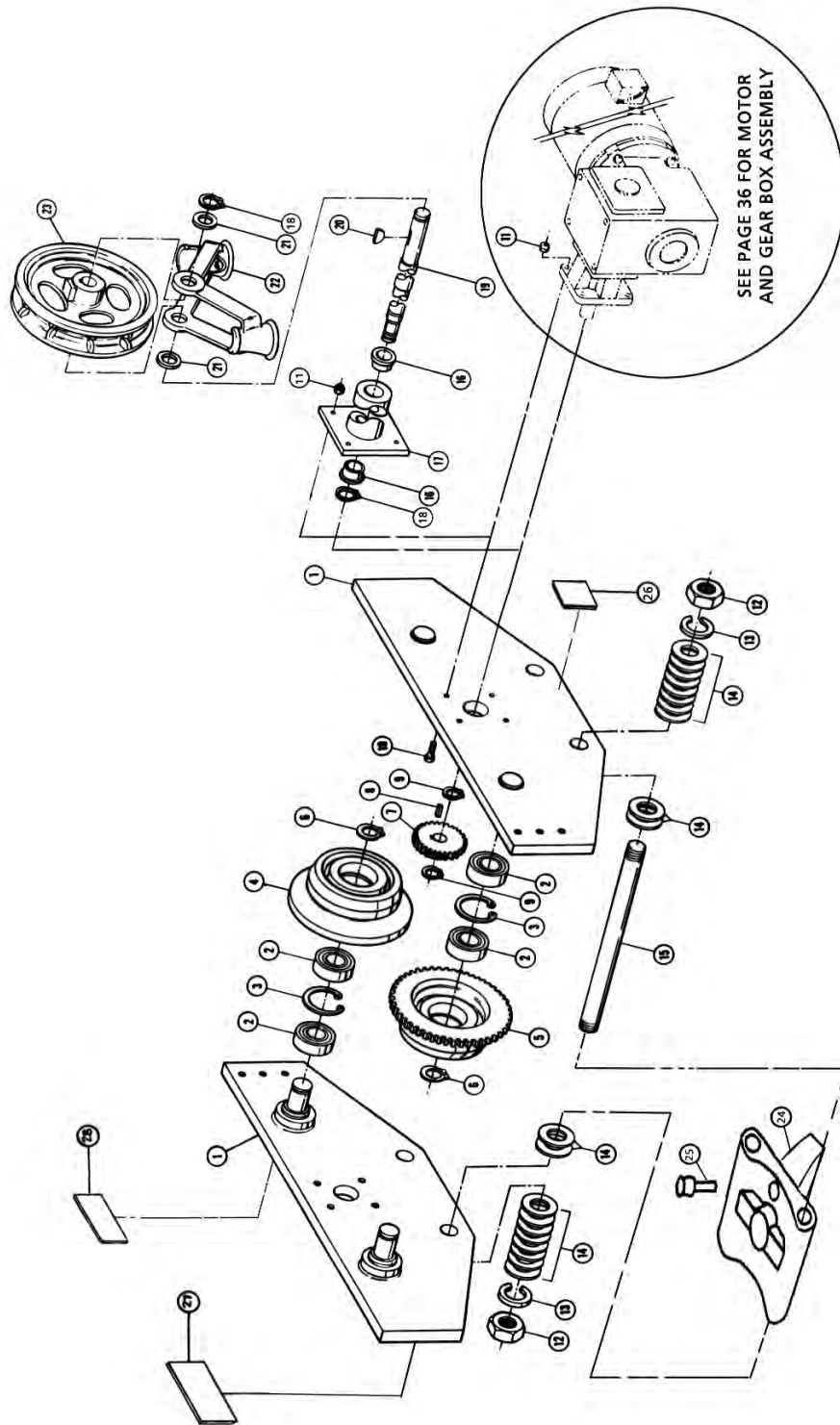

**3 THRU 7½ TON  
PLAIN, GEARED AND MOTOR DRIVEN  
TROLLEYS  
EXPLODED VIEW**

REF. NO.	NO. REQ'D	PART DESCRIPTION	PART NUMBER					
			3 TON			4-7 1/2 TON		
			PLAIN	GEARED	MOTOR DRIVEN	PLAIN	GEARED	MOTOR DRIVEN
1	2	SIDE PLATE ASSEMBLY FOR: 4" TO 6 1/4" FLG. AND PATENTED TRACK 6 3/8" TO 8 5/8" FLG. 8 3/4" TO 11" FLG.	700T-1400	700T-1700	BET-2800	700T-1501	700T-1801	BET-3801
			700T-1402	700T-1701	BET-2801	700T-1504	700T-1803	BET-3803
			700T-1404	700T-1702	BET-2802	700T-1507	700T-1805	BET-3805
2	8	BALL BEARING	700T-1406	700T-1703	BET-2803	700T-1514	700T-1811	BET-3811
3	4	RETAINING RING	700T-1407	700T-1704	BET-2804	700T-1516	700T-1813	BET-3813
4	2	*TRACKWHEEL-PLAIN STANDARD PATENTED TRACK SPARK RESISTANT	700T-1408	700T-1705	BET-2805	700T-1518	700T-1815	BET-3815
			700T-1409	700T-1706	BET-2806	700T-1520	--	BET-3817
			700T-1410	700T-1707	--	700T-1521	700T-1818	--
5	2	TRACKWHEEL-GEARED STANDARD PATENTED TRACK SPARK RESISTANT	--	700T-1708	BET-2807	--	700T-1820	BET-3818
			--	700T-1709	BET-2808	--	--	BET-3820
			--	700T-1710	--	--	700T-1823	--
6	4	RETAINING RING	700T-1411	700T-1711	BET-2809	700T-1523	700T-1825	BET-3821
7	1	PINION	--	700T-1719	BET-2810	--	700T-1846	BET-3823
8	1	PINION KEY	--	700T-1720	BET-2811	--	700T-1847	BET-3824
9	2	**RETAINING RING	--	700T-1718	BET-2812	--	700T-1845	BET-3825
10	4	HEX CAP SCREW	--	700T-1721	BET-2813	--	700T-1848	BET-3826
11	4	SELF LOCKING NUT	--	700T-1725	BET-2814	--	700T-1853	BET-3828
12	4	HEX JAM NUT	700T-1412	700T-1712	BET-2815	700T-1526	700T-1828	BET-3830
13	4	LOCKWASHER	700T-1414	700T-1713	BET-2816	700T-1529	700T-1831	BET-3833
14	40	SPACER WASHERS	700T-1416	700T-1714	BET-2817	700T-1532	700T-1834	BET-3836
15	2	SUSPENSION PIN FOR: 4" TO 6 1/4" FLG. AND PATENTED TRACK 6 3/8" TO 8 5/8" FLG. 8 3/4" TO 11" FLG.	700T-1418	700T-1715	BET-2818	700T-1535	700T-1837	BET-3839
			700T-1420	700T-1716	BET-2819	700T-1537	700T-1839	BET-3841
			700T-1422	700T-1717	BET-2820	700T-1539	700T-1841	BET-3843
16	2	BUSHING	--	700T-1723	--	--	700T-1851	--
17	1	PLATE AND TUBE ASSEMBLY	--	700T-1724	--	--	700T-1852	--
18	2	RETAINING RING	--	700T-1722	--	--	700T-1850	--
19	1	HANDWHEEL SHAFT	--	700T-1726	--	--	700T-1854	--
20	1	HANDWHEEL SHAFT KEY	--	700T-1727	--	--	700T-1856	--
21	2	WASHER	--	700T-1728	--	--	700T-1857	--
22	2	CHAIN GUIDE 8 5/8" O.D. HAND CHAIN WHEEL 11 5/8" O.D. HAND CHAIN WHEEL	--	700T-1729	--	--	--	--
			--	700T-1730	--	--	700T-1858	--
23	1	HAND CHAIN WHEEL 8 5/8" OUTSIDE DIAMETER 11 5/8" OUTSIDE DIAMETER	--	700T-1731	--	--	--	--
			--	700T-1732	--	--	700T-1860	--
24	1	SUSPENSION ADAPTER	52784			52787		
25	1	SUSPENSION ADAPTER SCREW	80430			80430		
26	1	WARNING LABEL	--	936986		--	936986	
27	1	TROLLEY CAPACITY LABEL	52764			52765		
28	1	WARNING LABEL	936984			936984		
***	AS REQ'D	HAND CHAIN (NOT SHOWN) STANDARD SPARK RESISTANT	--	700T-1733	--	--	700T-1862	--
			--	700T-1734	--	--	700T-1863	--

\* TOTAL QUANTITY OF 4 EACH REQUIRED FOR PLAIN TYPE TROLLEYS.

\*\* TOTAL QUANTITY OF 1 EACH REQUIRED FOR 3 TON TROLLEYS.

\*\*\* SPECIFY LENGTH OF HAND CHAIN REQUIRED. STANDARD LENGTH EQUALS TWO TIMES HOIST LIFT PLUS 2'-6".

Parts List			
Key No.	Part Name	Number Required	Part Number
627-552	Control Station (Items 627-553, 627-554, 627-555, 627-563, 627-565 and 627-820)	1	28630
627-551	Control Station Kit Consists of: 1-Neoprene Grommet 1-Grommet Retainer Ring 2-Grommet Retainer Ring Attaching Screw 4-Cover Attaching Screw	1	28627
627-553	Case	1	28873
627-554	Gasket	1	28876
627-555	Cover Assembly (Decal & Rocker included)	1	51477
627-563	Control Station Parts Kit Consists of: 1-Strain Cable Attaching Screw 1-Strain Cable Attaching Screw Washer 2-Switch Mounting Pin 2-Pin Retainer Screw 2-Switch Leaf Spring	1	51481
627-565	Control Station Switch Kit Consists of: 2-Switch 1-Jumper 1-Terminal 1-Screw	1	51472
627-820	Warning Label	1	24842

\*Also order control Station Kit Key No. 627-551, Part No. 28627.

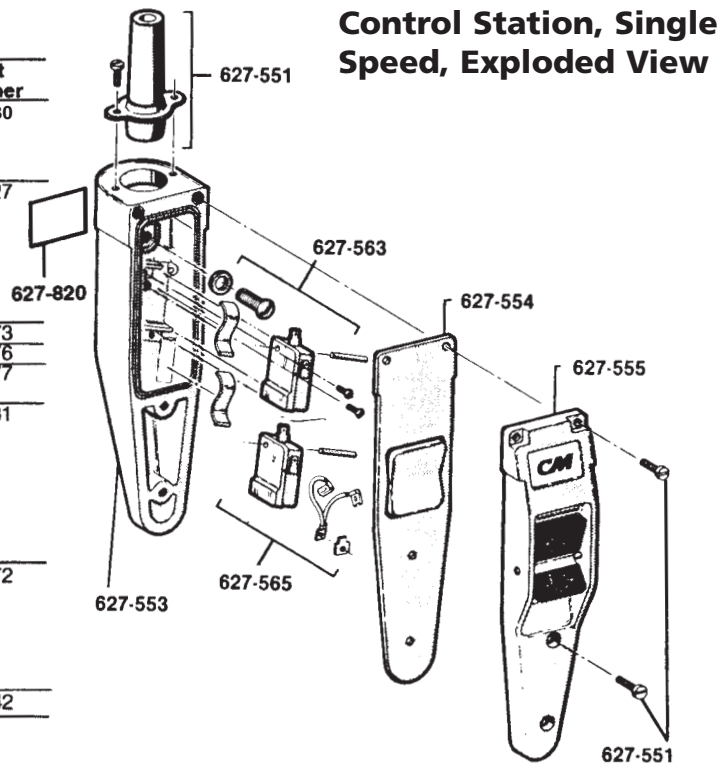

Parts List			
Key No.	Part Name	Number Required	Part Number
627-551	Control Station Kit Consists of: 1-Neoprene Grommet 1-Grommet Retainer Ring 2-Grommet Retainer Ring Attaching Screw 6-Cover Attaching Screw	1	36634
627-553	Case	1	28872
627-554	Gasket	1	28875
627-555	Cover Assembly (Decal and Rocker included)	1	51478
627-563	Control Station Parts Kit Consists of: 1-Spring 1-Strain Cable Attaching Screw 1-Strain Cable Attaching Screw Washer 2-Switch Attaching Pin 1-Sliding Cam 2-Spring End Support 3-Switch Mounting Plate & Rocker Assembly Attaching Screw 1-Rocker Assembly 1-Cam Return Spring	1	51473
627-565	Control Station Switch Kit Consists of: 3-Switch 2-Insulator 1-Jumper	1	51474
627-820	Warning Label	1	24842
627-872	Control Station (Items 627-553 thru 627-555, 627-563, 627-565 and 627-820)	1	*36693

\*Also order control Station Kit  
Key No. 627-551, Part No. 36634

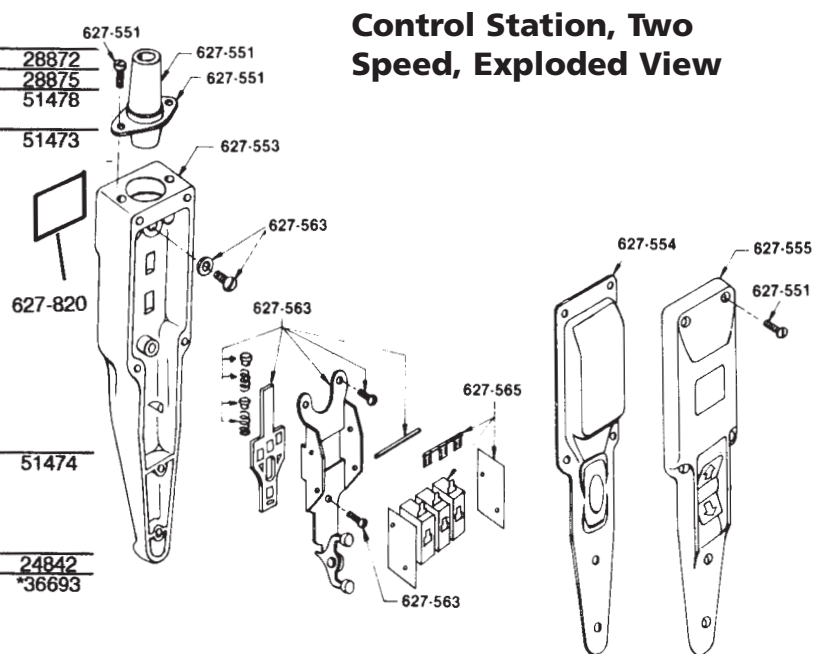

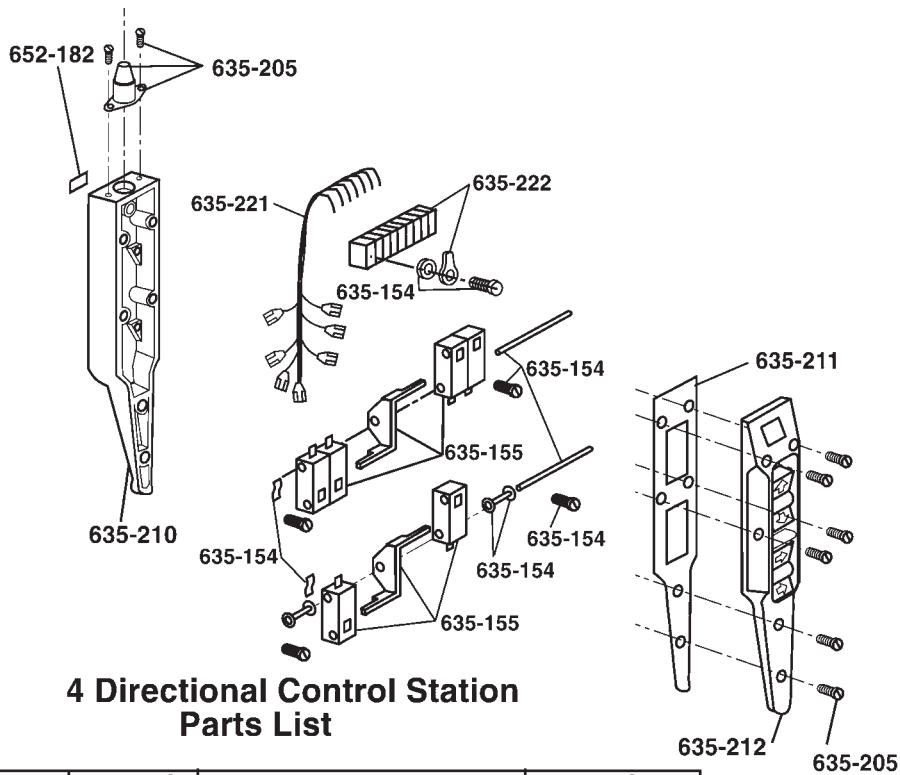

### 4 Directional Control Station Parts List

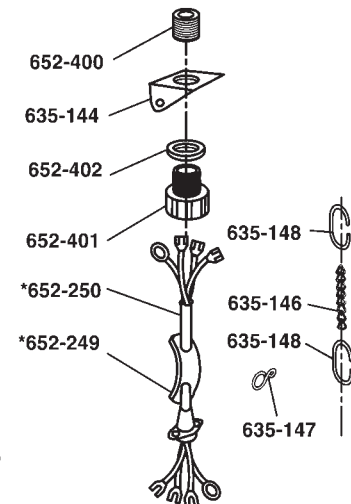

### Control Cord, Chain Strain Relief and Related Parts

\*Refer to parts list on pages for  
information on these parts

Key No.	No. Req'd	Part Name	Part Number
635-144	1	Chain clip at hoist: 68704 for control cord with 8 conductors, 57817 for control cord with 10 conductors	--
635-146	--	Control station support chain (Specify length req'd)	621431
635-147	--	Cable clip-specify no. req'd	54749
635-148	--	Open link-specify no. req'd	59883
635-154	1	Control station parts kit consisting of: 1-Strain cable attach. screw 1-Terminal strip spacer 2-Switch mounting pins 4-Pin retainer screws 2-Switch spacers 2-Switch spacer washers 6-Leaf springs	71601
635-155	1	Control station switch kit Consisting of: 6-Switch 2-Interlocks	71602
635-156	1	Control station complete: *CM 4 directional (1 or 2 speed hoist with 1 speed trolley) 6 button Series 8000 (on-off, 1 speed hoist, 1 speed trolley) (For other control stations, contact CM.)	70620 58252 -
635-205	1	Control station kit consisting of: 1-Grommet 1-Grommet retaining ring 2-Retaining ring screws 6-Cover screws	70507
635-210	1	Case	28874
635-211	1	Gasket	28877
635-212	1	Cover assembly (cover, rockers and decal)	71604
635-221	1	Wiring harness	51546
635-222	1	Terminal strip and mounting lug kit consisting of: 1-Terminal strip 2-Mounting lug	71603
652-186	1	Warning label	24842
652-400	1	Reducer (1" to 3/4")	89946
652-401	1	Connector for: 8 Conductor cord (3/4") 10 Conductor cord (1")	983979 83982
652-402	1	Sealing Ring For: 8 Conductor cord (3/4") 10 Conductor cord (1")	983963 984901

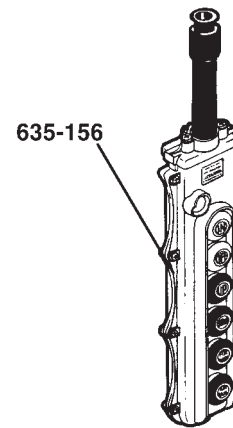

**Series 8000 Control  
Station-Individual  
components not  
available for repair**

**Multifunction  
Control Stations**

\* Also order control station kit part number 70507



### 3 THRU 7½ TON TROLLEY MOTOR BRAKE EXPLODED VIEW

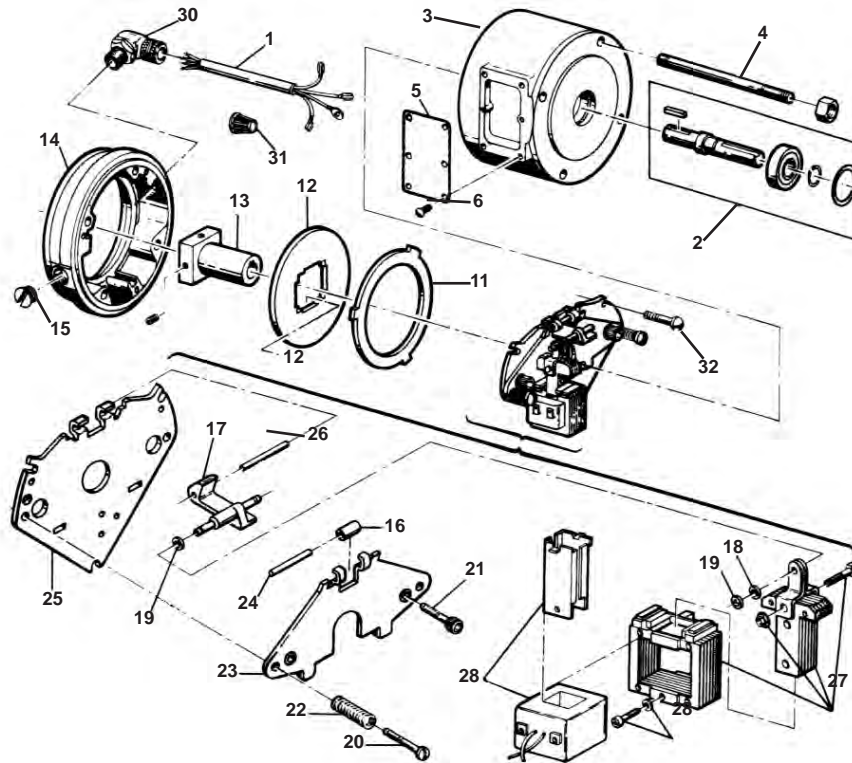

Key No.	No. Req'd	Part Name	Part Number
1	1	Brake Cord	51074
2	1	Coupler Brake Shaft Kit (includes Shaft, Bearing, Snap Ring, Retainer Ring and Key)	
3	1	Housing	
4	4	Mounting Stud with Nut	
5	2	Access Cover -Plain	
6	-	Access Cover Screw (Specify No. Req'd.)	
7	2	*Access Cover Gasket	
8	1	*Drain Plug	
9	1	*Housing To End Plate Gasket	
10	2	*Gasket-Each End Of Brake	
11	1	Stationary Disc	
12	1	Friction Disc Kit (Includes 3 Discs With Stabilizer Spring-Only One Disc Req'd.Per Brake)	
13	1	Hub Kit (Included Hub And Set Screws)	
14	1	End Plate Assembly	
15	1	Plug-External Lead Hole	
16	1	Bearing	
17	1	Solenoid Lever	
18	1	Retaining Ring	
19	2	Spacer	
20	2	Torque Adjusting Screw	
21	2	Wear Adjusting Screw	
22	2	Pressure Spring	
23	1	Lever Arm And Stop Nut Assembly	
24	1	Bearing Pin	
25	1	Support Plate And Stop Nut Assembly	
26	1	Pivot Pin	
27	1	Solenoid Kit (Includes Plunger, Link, Frame Link Screw, Link Nut And Mounting Screws)	
28	1	Coil Kit (Includes Coil, Plunger Guides, Guide Screw and Locwashers)	
29	1	Motor Brake Kit (Includes Complete Brake Assembly, Brake Cord, Connector Wire Nuts and Installation Instructions)	9598 for 220, 230 380 & 460 Volt Brake
30	1	Brake Cord Connector	83968
31	4	Wire Nut	982473
32	3	Brake Attaching Screw	Contact Factory
33	1	**Access Cover With Manual Release Knob	Contact Factory

Contact Factory  
For  
Part Numbers  
Of  
Brake  
Components  
Key Numbers  
2 Thru 28,  
32 And 33

\* For Weatherproof Units-Not Shown

\*\*Not Shown

Note: When ordering parts, always furnish Hoist Model and Serial Number, Motor Horsepower, Voltage, Phase, Frequency and Rated Capacity of hoist on which the parts are to be used.  
For the location of the nearest Master Parts Depot, see the list located on the inside front cover.

## LIMITATION OF WARRANTIES, REMEDIES AND DAMAGES

THE WARRANTY STATED BELOW IS GIVEN IN PLACE OF ALL OTHER WARRANTIES, EXPRESS OR IMPLIED, OF MERCHANTABILITY, FITNESS FOR A PARTICULAR PURPOSE, OR OTHERWISE, NO PROMISE OR AFFIRMATION OF FACT MADE BY ANY AGENT OR REPRESENTATIVE OF SELLER SHALL CONSTITUTE A WARRANTY BY SELLER OR GIVE RISE TO ANY LIABILITY OR OBLIGATION.

Seller warrants that on the date of delivery to carrier the goods are free from defects in workmanship and materials.

SELLER'S SOLE OBLIGATION IN THE EVENT OF BREACH OF WARRANTY OR CONTRACT OR FOR NEGLIGENCE OR OTHERWISE WITH RESPECT TO GOODS SOLD SHALL BE EXCLUSIVELY LIMITED TO REPAIR OR REPLACEMENT, F.O.B. SELLER'S POINT OF SHIPMENT, OF ANY PARTS WHICH SELLER DETERMINES TO HAVE BEEN DEFECTIVE or if Seller determines that such repair or replacement is not feasible, to a refund of the purchase price upon return of the goods to Seller.

Any action against Seller for breach of warranty, negligence or otherwise, must be commenced within one year after such cause of action accrues.

NO CLAIM AGAINST SELLER FOR ANY DEFECT IN THE GOODS SHALL BE VALID OR ENFORCEABLE UNLESS BUYER'S WRITTEN NOTICE THEREOF IS RECEIVED BY SELLER WITHIN ONE YEAR FROM THE DATE OF SHIPMENT.

Seller shall not be liable for any damage, injury or loss arising out of the use of the goods if, prior to such damage, injury or loss, such goods are (1) damaged or misused following Seller's delivery to carrier; (2) not maintained, inspected, or used in compliance with applicable law and Seller's written instructions and recommendations; or (3) installed, repaired, altered

or modified without compliance with such law, instructions or recommendations.

UNDER NO CIRCUMSTANCES SHALL SELLER BE LIABLE FOR INCIDENTAL OR CONSEQUENTIAL DAMAGES AS THOSE TERMS ARE DEFINED IN SECTION 2-715 OF THE UNIFORM COMMERCIAL CODE.

### INDEMNIFICATION AND SAFE OPERATION

Buyer shall comply with and require its employees to comply with directions set forth in instructions and manuals furnished by Seller and shall use and require its employees to follow such instructions and manuals and to use reasonable care in the use and maintenance of the goods. Buyer shall not remove or permit anyone to remove any warning or instruction signs on the goods. In the event of personal injury or damage to property or business arising from the use of the goods, Buyer shall within 48 hours thereafter give Seller written notice of such injury or damage. Buyer shall cooperate with Seller in investigating any such injury or damage and in the defense of any claims arising therefrom.

If Buyer fails to comply with this section or if any injury or damage is caused, in whole or in part, by Buyer's failure to comply with applicable federal or state safety requirements, Buyer shall indemnify and hold Seller harmless against any claims, loss or expense for injury or damage arising from the use of the goods.

**For more information contact:**  
**American Crane & Equipment Corp.**  
**Authorized Distributor**  
**Tel: 877-503-2972**  
**Fax: 484-945-0430**  
**sales@americancrane.com**  
**www.americancrane.com**

### **WARNING**

Alterations or modifications of equipment and use of non-factory repair parts can lead to dangerous operation and injury.

#### **TO AVOID INJURY:**

- Do not alter or modify equipment
- Do use only factory provided replacement parts.



Columbus McKinnon Corporation  
140 John James Audubon Parkway  
Amherst, New York 14228-1197  
Phone: (800) 888-0985  
Fax: (716) 689-5644



Lift-Tech International  
414 West Broadway Ave.  
Muskegon, Michigan 49443-0769  
Phone: (231) 733-0821  
Fax: (800) 742-9270