

**AW SERIES
AIR POWERED HOISTS**

Parts and Instructions Manual

For more information contact:
American Crane & Equipment Corp.
Authorized Distributor
Tel: 877-503-2972
Fax: 484-945-0430
sales@americancrane.com
www.americancrane.com

3343

Yale

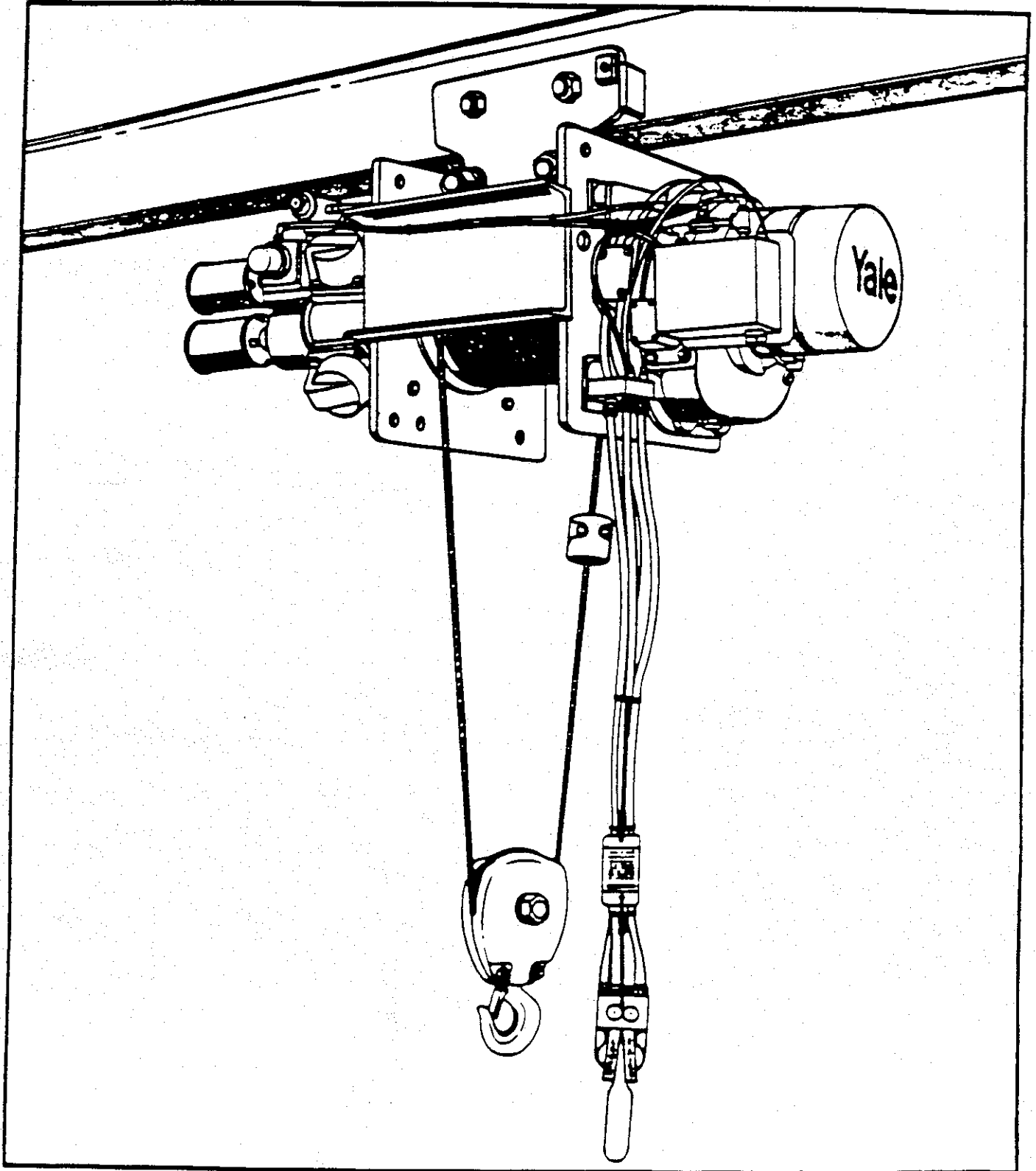

REFER TO PARTS LIST IN FRONT COVER FOR COMPONENT NBR. ADDITIONAL INFORMATION CAN BE FOUND UNDER THESE SECTIONS OR ASSEMBLIES HIGHLIGHTED BY AN *

IMPORTANT REVIEW THIS PAGE

PROCEDURE FOR LOCATING REPAIR PART INFORMATION

① USE HOIST EXPLODED VIEW(S) TO SELECT **SECTION NUMBER.**

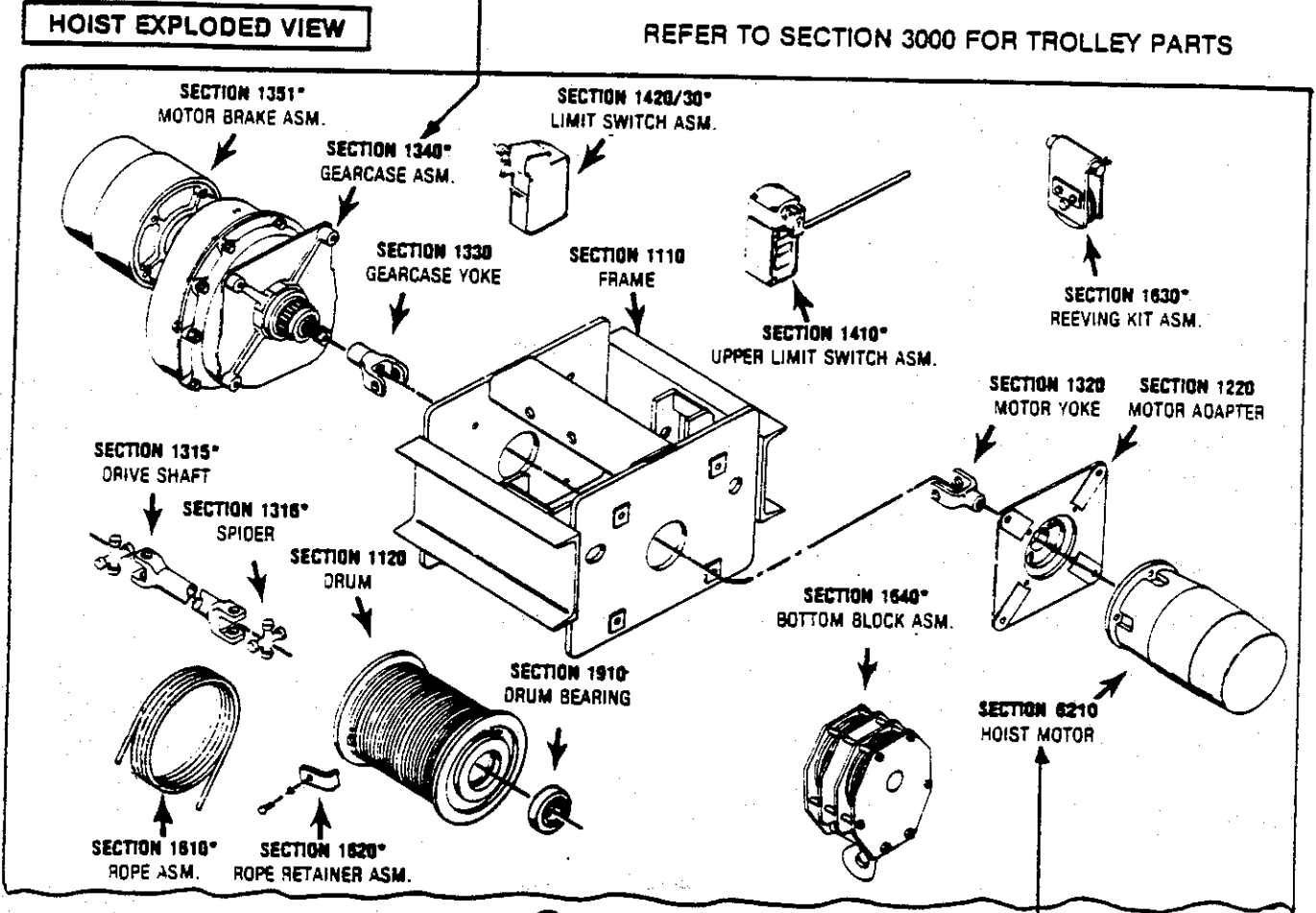

② **COMPONENT PART NUMBER:** REFER TO PARTS LIST AND SELECT

PARTS LIST				
Parent Number	Description	Component Number	Section Number	Qty. Per Unit
XXXXXXXXXX	Frame	647664103	1110	1.000
XXXXXXXXXX	Drum	645100103	1120	1.000
XXXXXXXXXX	Hoist Motor	642885800	1210	1.000
XXXXXXXXXX	Adapter, Motor	648494100	1220	1.000

ADDITIONAL INFORMATION. → ③ AVAILABLE FOR THESE SECTIONS.

SECTION 1351
MOTOR BRAKE
6438061-01 — 13

DIRECT ACTING BRAKE

TROLLEY

COMPONENTS

REFER TO PARTS LIST IN FRONT COVER FOR COMPONENT NBR. ADDITIONAL INFORMATION CAN BE FOUND UNDER THESE SECTIONS OR ASSEMBLIES HIGHLIGHTED BY AN *

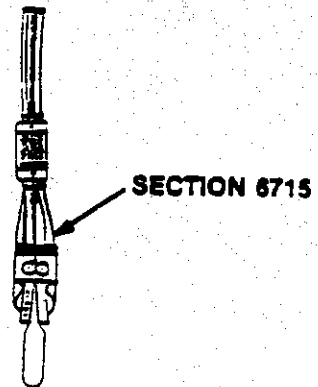
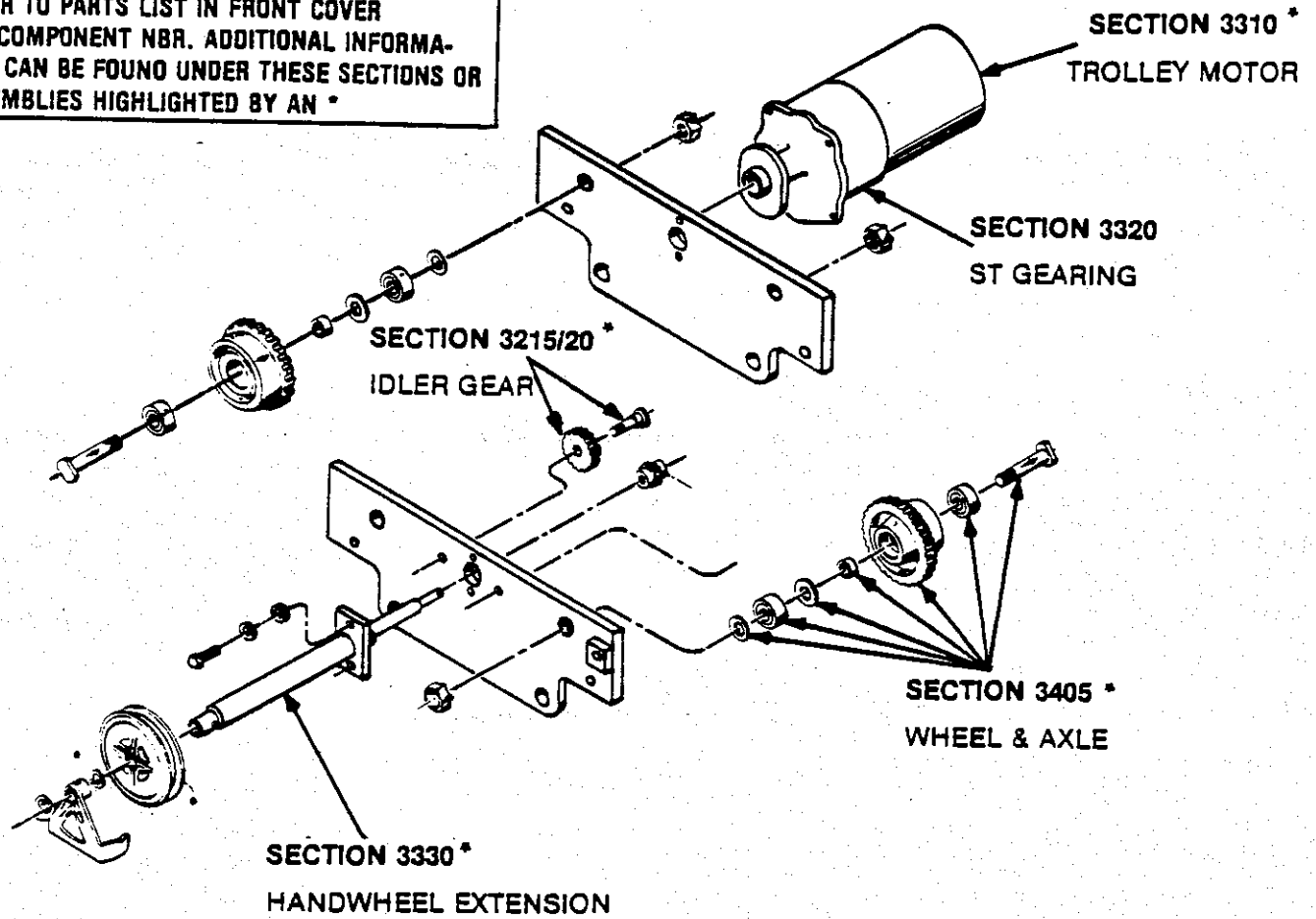

When Replacement Parts Are Needed, Order Only Yale® Factory Engineered Parts

COMMON MODEL NUMBER CODE FOR POWERED HOISTS

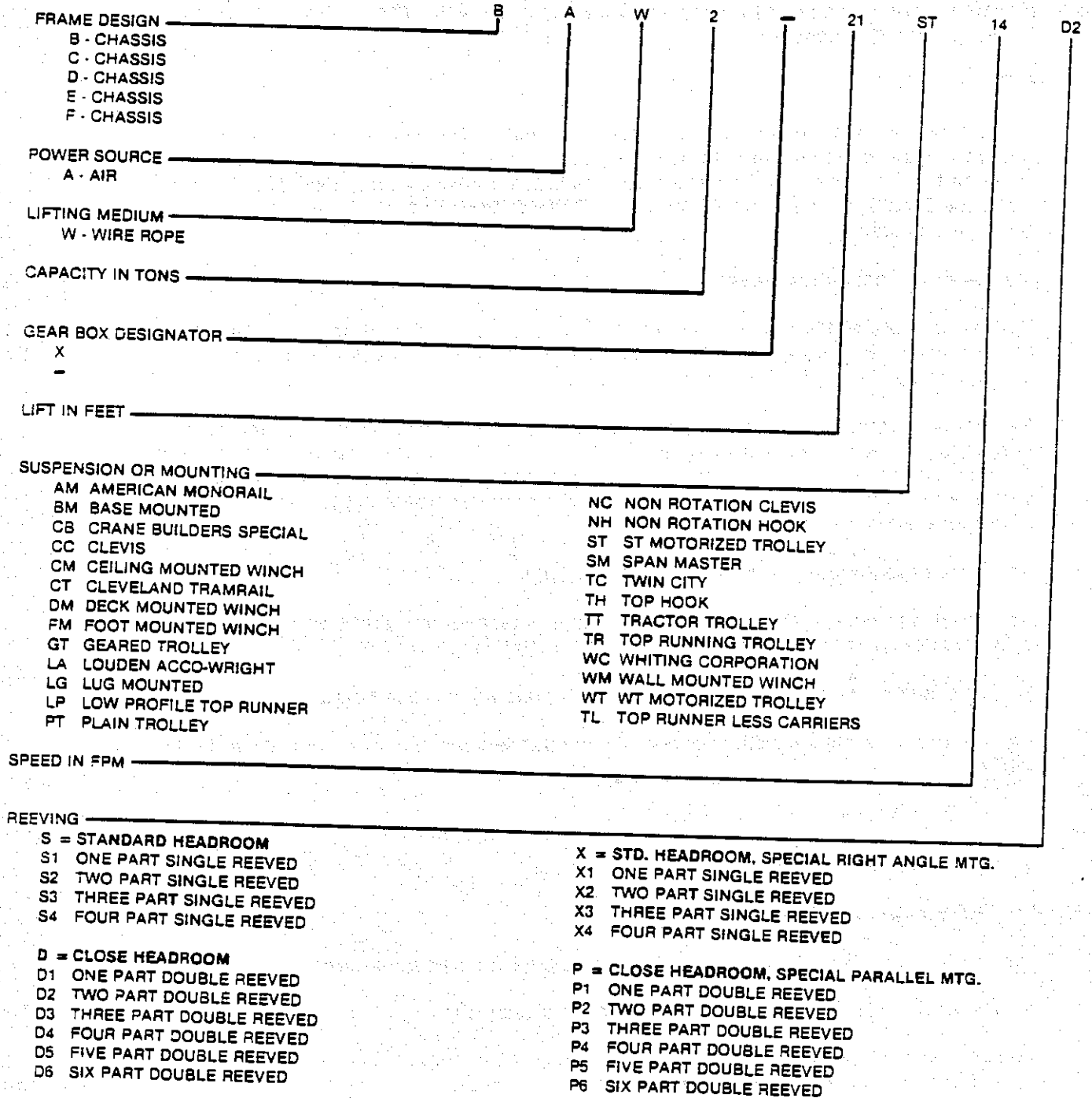

When Replacement Parts Are Needed, Order Only Yale® Factory Engineered Parts

SECTION A SAFE HOISTING PRACTICES

For your own safety and that of your fellow workers, Material Handling Equipment must be used as recommended by the manufacturer. Failure to heed the following recommendations could endanger your life. Use good common sense and judgment at all times. Safety is the responsibility of the operator of the equipment. You must be competent and attempt to foresee and avoid all hazardous conditions. To be safe as possible, the hoist must be given proper preventive maintenance and testing as described in the **ANSI B30.16 Safety Code for Overhead Hoists** and this manual.

BEFORE OPERATING HOIST

1. Do not operate hoist unless you are properly trained, physically fit, and authorized to do so. You must be familiar with all operating controls of the hoist, warnings and instructions on the hoist, the safe hoisting practices listed in this manual, **ANSI B30.16 Safety Code for Overhead Hoists**, and all pertinent Federal, State, and Local regulations before beginning operating.
2. Do not allow unqualified personnel to operate the hoist.
3. Test all controls and limit switches and make sure hoist is well lubricated at beginning of each shift. Make sure needed lubrication, adjustments or repairs are made by appointed personnel before operations are begun.
4. Be familiar with the equipment and its proper care. Do not operate hoist if adjustments or repairs are necessary, if any damage or undue wear is known or suspected, or if any warning, operating, or capacity instructions normally attached to hoist are damaged, obscured or missing. Report these items promptly to the proper person and also notify next operator when changing shifts.
5. Do not operate hoist if it is functioning improperly.
6. Do not operate hoist with an out - of - order sign attached until sign has been removed by a properly authorized person.
7. Do not adjust or repair hoist unless qualified for maintenance of hoist.
8. Be sure the air supply is disconnected before maintenance and repair procedure is performed.
9. Do not use the wire rope as a ground for welding.
10. Do not touch a welding electrode to the wire rope.

APPLYING THE LOAD

11. Never wrap the wire rope around the load, or allow it to drag under load.
12. Always use slings or other approved devices to attach load.
13. Be sure the sling is properly seated in the saddle of the hook. Do not allow hook latch to support any part of load.

When Replacement Parts Are Needed, Order Only Yale® Factory Engineered Parts

APPLYING LOAD (Continued)

14. Do not apply a load to tip of hook, or in such a way as to cause bending or prying forces on the hook or hook support block.
15. Be sure wire ropes are not kinked or twisted or that multiple part ropes are not twisted about each other.
16. Do not operate hoist if wire rope is not seated properly in the grooves of the drum or sheaves.
17. Do not load hoist with less than two wraps of rope on the drum, unless a lower limit device is provided, in which case, no less than one wrap shall remain on drum.
18. Center hoist unit over the load before lifting. Avoid side pull.
19. Never pick up a load beyond the rated capacity appearing on the hoist, except for properly authorized tests.
20. Do not use a load limiting device to measure the maximum load to be lifted. It is a safety device only.

MOVING THE LOAD

21. Do not engage in any activity which will divert your attention while operating hoist.
22. Respond to signals from designated personnel only, except for stop signals.
23. Never lift a load with the hoist until you and all other personnel are clear of load.
24. Make sure load has proper clearance before moving.
25. Inch the hoist slowly into engagement with a load, but avoid excessive plugging, inching, and quick reversals of load.
26. Do not lift load more than a few inches until it is well balanced in the sling or lifting device.
27. Each time a load approaching rated capacity is handled, check load brake action by raising load just clear of supports and continuing only after you are sure brake is operating properly.
28. Do not transport load over personnel.
29. Never carry personnel on the hook or the load.
30. Avoid swinging of load or load hook when traveling the hoist.
31. On trolley mounted hoists, avoid sharp contact between trolleys or between trolleys and rail stops.
32. Do not use limit devices as a normal means of stopping the hoist. These are emergency devices only.
33. Do not exceed the maximum duty cycle specified by the manufacturer.

When Replacement Parts Are Needed, Order Only Yale® Factory Engineered Parts

SECTION A

PARKING

34. Do not leave load suspended in the air for extended or unattended periods.
35. Keep load block above head level when not in use.

SAFETY LAWS FOR PASSENGER ELEVATORS

The safety laws for passenger elevators specify construction details that are not incorporated in Yale Industrial Hoists. We recommend that passenger elevator operation equipment be used that meets all state and national safety codes. Yale Industrial Products, Inc. will not accept responsibility for applications of Yale Hoists on passenger elevators.

INSPECTION, PREVENTIVE MAINTENANCE AND TESTING

A preventive maintenance program should be initiated for this hoist immediately after it is entered into service. The preventive maintenance program should comply with recommendations in the applicable Yale Parts and Instruction Manual, and all pertinent National, Federal, State and local regulations. Regular inspections, maintenance, and testing required should be followed for the life of the hoist and written inspection records kept as specified. Sample inspection check lists are included at back of this manual. Extra inspection check lists can be obtained from your nearest authorized Yale Distributor.

When Replacement Parts Are Needed, Order Only Yale® Factory Engineered Parts

SECTION B

REPAIR PARTS ORDERING INFORMATION

This parts and instruction manual contains information required to install and maintain your Yale AW Series Air Hoist. To insure prompt service, each repair parts order should be placed with your local distributor, and must contain the following information:

Please give all information listed below in items (a) thru (e). This will enable your distributor to fill your order promptly.

- (a) Give complete data from hoist nameplate, including hoist serial number and model number.
- (b) Give part numbers, description and quantity of parts required.
- (c) Give correct shipping destination.
- (d) For ordering motor repair parts, give all data on the hoist and motor nameplates.
- (e) If hoist has been purchased for a special application or environment (such as plating, spark resistant, special hook, special controls, etc.), some of the standard parts listed in this manual may not apply and some special parts may not be shown. In such cases you should contact the factory or your nearest Yale authorized repair station for assistance in ordering parts. A full description of the special application or environment for which the hoist has been adapted will be required.

HOIST SERIAL NUMBERS

The hoist serial number is stamped in the suspension frame and nameplate. Trolley serial numbers are stamped on the trolley sideplate. The nameplates also designate the model number, capacity, speed, current characteristics, and service rating of the hoist or trolley.

RETURN OF PARTS

If it becomes necessary to return the complete hoist or certain parts to the factory, a letter requesting such a return is necessary. This letter should contain an explanation for requesting the return. A return authorization will be issued giving you clearance for returning the hoist or parts to the factory.

When Replacement Parts Are Needed, Order Only Yale® Factory Engineered Parts

JANUARY 1984

RECOMMENDED SPARE PARTS LIST FOR ONE YEAR OPERATION SECTION B
AW SERIES

Unit Model Number _____ Serial Number _____
 Customer P.O. _____ Customer Name _____
 Voltage _____ Yale Order Number _____

The following parts are unique to each hoist model. Use the parts manual section indicated below, find the part number for your model hoist on parts list in front cover and complete the form below.

ITEM	REF. SECTION	PART NUMBER	QTY./ UNIT
WIRE ROPE ASSEMBLY	1610	_____	1
LOAD BRAKE SPARE PARTS KIT			
BAW -	1340	6460192-00	1
BAW X & CAW -	1340	6460202-00	1
CAW X & DAW -	1340	6460212-00	1
DAW X & EAW -	1340	6460222-00	1
EAW X & FAW -	1340	6452334-00	1
GEARCASE SEAL KIT			
BAW -	1340	6460142-00	1
BAW X & CAW -	1340	6460152-00	1
CAW X & DAW -	1340	6460162-00	1
DAW X & EAW -	1340	6460172-00	1
EAW X & FAW -	1340	6460182-00	1
MOTOR BRAKE (REBUILD KIT)			
BAW - Model TSE-450	1351	6461063-11	1
CAW - Model TSE-600	1351	6461063-12	1
DAW - Model TSE-600	1351	6461063-12	1
EAW - Model TSE-600	1351	6461063-12	1
FAW - Model TSE-800	1351	6461063-13	1
MOTOR GASKET & SEAL KIT			
For Motor 6451822-01 & -02 - Model RM-210	1210	6465973-02	1
For Motor 6499681-00 Model RM-310	1210	6465973-03	1
For Motor 6499741-00 Model RM-410	1210	6465973-04	1
For Motor 6451843-00 Model RM-510	1210	6465973-05	1
LIMIT SWITCH CONTACTS			
TRAVELING NUT	1420 / 30	Select Complete Switch	2
ROTATING CAM	1420 / 30	_____	2
UPPER LIMIT SWITCH	1410	Select Complete Switch	1
CONTROLS			
LEVER CONTROL PENDANT	2710 / 80	_____	1
BOTTOM HOOK	1640	Select Hook _____	1
HOOK LATCH KIT	1640	_____	1

When Replacement Parts Are Needed, Order Only Yale® Factory Engineered Parts

INSTALLATION INSTRUCTIONS

Before the unit is shipped from the factory it is rigidly tested and carefully adjusted for proper operation. However, the following points must be checked to insure correct installation and avoid damage to the hoist.

Suspension - Suspend the hoist following the installation procedures for the type of suspension used on your hoist. See pages 11.

Rope And Drum - Check the hoist rope for any signs of damage and make sure it lies properly in the grooves of the drum and sheaves. Make sure the rope is well lubricated. (See chart on page 16.)

 **CAUTION** BEFORE OPERATING THE HOIST, REMOVE THE WOODEN SHIPPING WEDGE LOCATED ON TOP OF THE ROPE BETWEEN THE DRUM AND SUSPENSION FRAME.

Lubrication - Every attempt has been made to ship the hoist with the proper amount of lubricating oil in the gearcase. Before placing the unit in operation, remove the level plug in the gear housing and check the oil level. The oil should be level with the level hole. If more oil is needed consult the Lubrication Chart on page 16. Also make sure breather plug hole is cleared.

Air Supply - Before connecting air to hoist, make sure the pressure of the air supply corresponds with the rating listed on the hoist nameplate. An automatic air line oiler set to feed at approximately one drop per minute, a moisture trap, and a filter should be installed in the air line not more than 15 ft. from the hoist inlet connection.

NOTE: THE MINIMUM RECOMMENDED SUPPLY HOSE DIAMETER IS ONE INCH. AIR CONSUMPTION AT RATED SPEED AND PRESSURE IS GIVEN ON THE HOIST NAMEPLATE.

Yale	
Capacity, tons _____	
Speed, fpm, Hoist _____ Trolley _____ at 90 psi	
Model _____	
Serial _____	
Air Consumption at rated speed, CFM _____	
Order No. _____	
Yale Industrial Products, Inc. Forrest City, Arkansas 72335	

NOTE THESE FIGURES

When Replacement Parts Are Needed, Order Only Yale® Factory Engineered Parts

SECTION B

INSTALLATION INSTRUCTIONS (Continued)

Adjustment Of Limit Switches

1. UPPER LIMIT SWITCH - (NOT USED ON WINCH MODELS)

After the hoist is determined to be running in the proper direction, lower the hook to approximately eight feet (8) below the hoist. Check the limit switch by running the hook upward and lifting the rod or weight by hand. When the rod or weight is lifted from one-half inch (1/2) to two inches (2) the hoist should cut-off.

2. TRAVELING NUT UPPER AND LOWER LIMIT SWITCH.

To adjust the traveling nut limit switches, or to set them at other levels:

- (a) Remove all air pressure from the hoist.
- (b) Loosen the limit switch cover screws and remove the cover.
- (c) Slide the locking plate from under the traveling nuts and turn both nuts until they meet at the center of the shaft.
- (d) Replace the locking plate under the traveling nuts.
- (e) Replace cover and hand tighten cover screws.
- (f) Apply air pressure to the hoist.
- (g) Run hoist to the desired lower limit.



WARNING AT LEAST 1 WRAP OF ROPE MUST REMAIN ON THE DRUM IN THE LOWEST POSITION.

- (h) Remove air pressure from the hoist and remove the switch cover.
- (i) Slide the locking plate from under the traveling nuts.
- (j) Rotate the lower nut (the one nearest to a contact) until it contacts. Continue rotating until the microswitch can be heard to trip.
- (k) Replace locking plate under the nuts. (Slight adjustment of traveling nuts may be necessary).
- (l) Replace cover and hand tighten cover screws.
- (m) Apply power and check lower limit switch operation. If minor adjustment is necessary, repeat steps (h) thru (m), rotating nut one step at a time until proper adjustment is accomplished.
- (n) Repeat step (g) thru (m) to adjust the upper limit switch, by substituting upper for lower in steps (g) thru (j).



WARNING WHEN UPPER LIMIT SWITCH IS USED, MAKE SURE GEARED LIMIT SWITCH TRIPS FIRST, ALLOWING THE ROD OR WEIGHT TYPE SWITCH TO ACT AS THE BACK-UP LIMIT.

3. SPECIAL GEARED TYPE UPPER AND LOWER LIMIT SWITCH

- (a) If special geared type upper and lower limit switch is used, see Section K-2 for installation, adjustment and maintenance instructions.
- (b) Note warnings in paragraph 2 above.

When Replacement Parts Are Needed, Order Only Yale® Factory Engineered Parts

Basic Suspensions - The basic hoist suspension types are ; lug mounted, frame mounted (various types), plain trolley, hand chain operated trolley, single beam under running motorized trolley, and top running motorized trolley for double rails. Before connecting hoist to supporting structure, or mounting on beam or rail, make sure supporting structure has adequate strength to safely support the loading which will be imposed.

When installing lug mounted or frame mounted types, make sure hoist is bolted securely in place with the proper size bolts, that it is level, that nuts on mounting hole bolts are tightened securely, and the lockwashers, or other means of locking the nuts are used.

If hoist is furnished with a motorized trolley, record the serial number in this book for future reference, and refer to the trolley manual included.

To hang hoist furnished with plain, hand chain operated, or under running motorized trolley, first determine the beam size on which the trolley is to be used, then refer to trolley adjustment instructions below for proper spacer arrangements. On top running motorized trolleys, make sure rail size is correct for wheels and that distance between rails is correct for trolley throughout entire rail lengths.

Trolley Adjustment - All Yale under running trolleys are properly adjusted at the factory to fit the I-Beam size stated on the order.

NOTE: When disassembling the trolley for installation on the I-Beam, take note of the arrangement of the spacers and washers for correct reassembly.

For installation on I-Beam other than the size preset at the factory, follow the instructions listed below.

Measure the I-Beam flange width and temporarily install the trolley sideplates on the hoist before installation to determine the exact distribution of washers.

The distance between track wheel flanges should be $3/16$ inches greater than the beam flange width for straight runway beams, and $3/16$ to $1/4$ inches on runway systems that include sharp curves. To keep the hoist centered under the I-Beam, the number of washers between the sideplates and the hoist lug should be the same or differ only by one (1) washer. The distribution of washers outside the trolley sideplates is unimportant except that the total number used must be sufficient to keep the nuts engaged.

NOTE: When installing hoist and trolley on beam, tighten nuts snugly so that the trolley sideplates are parallel and vertical.



CAUTION BE SURE THERE IS A LOCKWASHER UNDER EACH NUT.

After the hoist and trolley are installed on the I-Beam, operate the trolley over the entire length of the beam with a capacity load to be sure that adjustment and operation is satisfactory. Then tighten all sideplate nuts to maximum standard torque for bolt size used.

Trolley With Guide Rollers - To adjust trolleys equipped with guide rollers add spacers in even quantities on each side of the spacer block until the distance between guide rollers is $1/8$ inches wider than the beam flange width.

NOTE: When properly installed and adjusted the guide rollers should be $1/16$ inches from the edge of the I-Beam.

When Replacement Parts Are Needed, Order Only Yale® Factory Engineered Parts

SECTION B

PREVENTIVE MAINTENANCE SCHEDULE

The required periods between inspections will vary due to the wide range of duty cycles and operating conditions encountered with the type of equipment. The following recommended inspection periods are based on duty of specified service rating with single shift operation (40 hours per week) under normal environmental conditions. If the hoist is used under adverse environmental conditions it should be inspected more frequently.

Daily Inspection - Inspect the following items before operating hoist.

1. **Manual Controls** - Check all manual controls for proper operation.
2. **Air Line Connections** - Check for worn or frayed tubing, for loose connections and for damage to, or improper operation of, control pendant.
3. **Limit Switch** - Check the upper and lower limit switch by running the hook **without load**, and at the slowest speed obtainable, to the maximum up and maximum down positions. Then test with increasing speeds up to maximum. The switch should shut the hoist off before the bottom block contacts the rod or weight type limit switch at the upper extreme. At least 1 Wrap of rope should remain on the drum at the shut-off point at the lowest extreme. If adjustment is necessary, see pages 10.
4. **Hook** - Check for cracks or deformation. Check for damaged or missing latch. A bent or twisted hook indicates overloading or abuse of unit. Other load bearing components of the hoist or trolley should be inspected if overloading is apparent or suspected. The bottom hook must swivel freely.
5. **Wire Rope** - Check for proper seating in drum grooves. Check for wear, unstranding, fraying, kinks, or broken wires in the wire rope, and condition of end connections. (If damage is noted, see wire rope instructions under monthly inspection.)
6. **Hook Drift** - With a load, the hook should stop promptly when the pendant lever is released. Hook drift of more than 2 inches at slow speed indicates that either one or both of the hoist brakes is malfunctioning. (See monthly and annual inspection instructions for more details.)
7. **Unusual Conditions** - Excessive noise, oil leaks, etc. should be investigated.



CAUTION: DO NOT OPERATE THE HOIST IF ABOVE INSPECTION INDICATES THAT MAINTENANCE IS NEEDED.

Monthly Inspection

1. ALL ITEMS UNDER DAILY INSPECTION.
2. **Lubrication** - Check the level and condition of the gearcase lubricant. The level must be maintained at the gearcase level plug. If the level is low, check for leaks. Replace gaskets and shaft seals if necessary. An excessively black color lubricant indicates a chemical change in the lubricant caused by excessive heat from the load brake, which in turn is caused by heavy duty cycles. Lubricant that is very black in color must be replaced to prevent shortened life of drive components. Lubricate wire rope and other points as required. (See chart page 16)

CAUTION FOR OPTIMUM LUBRICATION AND LOAD BRAKE COOLING, OIL LEVEL MUST BE MAINTAINED AT THE LEVEL PLUG.

When Replacement Parts Are Needed, Order Only Yale® Factory Engineered Parts

Monthly Inspection (Continued)

3. **Hook** - Check hook retaining nuts and collars, and means used to secure them. Replace hook if throat opening is in excess of maximum shown in table on page 15, or if there is 10 degrees or more twist from normal plane of hook.
4. **Load Brake** - Check the function of the load brake by lifting a light load (approximately 25% of rated load) 6 to 12 inches above the floor. Disconnect electrical power and manually open the motor brake. The load may "creep" slowly while the motor brake is held open. This is normal. However, if the load falls to the floor the instant the motor brake is released, the load brake is not functioning properly and should be replaced.
5. **Air Supply System** - Check for leaking air lines and loose connections. Check control pendant for damage, leaks and proper operation.
6. **Bearings** - Check all bearings for noisy operation, which is an indication of wear.
7. **Hardware** - Check for loose bolts, nuts and rivets.
8. **Wire Rope** - Check condition of wire rope using inspection check list. (See instructions page 17.) Lubricate per chart on page 16 needed.



WARNING NEVER ALLOW WIRE ROPE TO OPERATE DRY.

9. **Warning Labels** - Check for absence or illegibility of warning decals and tags and replace if necessary.
10. **Supporting Structure Or Trolley** - If used, should be checked for continued ability to support the imposed loads. Check for loose suspension or support bolts, axle nuts, etc.
11. **Inspection Check List** - Fill out inspection check list at the back of this manual, sign, date and file for future reference.

Quarterly Inspection

1. **ALL ITEMS UNDER DAILY AND MONTHLY INSPECTIONS.**
2. **Gearing** - Remove gearbox inspection cover and visually inspect gearing for excessive or uneven wear of the gear teeth. Replace if necessary.
3. **Motor Brake** - Check for excessive or uneven wear of the discs and proper adjustments. (See Section 1350.)

When Replacement Parts Are Needed, Order Only Yale® Factory Engineered Parts

SECTION B Annual Inspection

1. ALL ITEMS UNDER DAILY, MONTHLY AND QUARTERLY INSPECTIONS.
2. **Hooks** - Magnetic particle or other suitable crack detecting inspection should be performed if need is indicated by external appearance. Check for loose retaining nuts and collars.
3. **Load Bearing Parts** - Check for worn, cracked or distorted parts, such as suspension housings, outriggers, clevises, yokes, hook blocks, suspension bolts, shafts, locking devices and bearings on hoist, (also on trolley, if so equipped).
4. **Load Brake** - (For all chassis except EAW - X & FAW -) Check load brake for worn discs, check operation of one way holding pawl. If either brake disc is worn 1/16 inches or more replace ratchet and disc assembly. New discs measure 3/16 inches thick. (See page 15.) (For EAW - X & FAW -) Check load brake for worn discs, check operation of one way sprag holding clutch. If either brake disc is worn 1/32 inches or more replace ratchet and disc assembly. New discs measure 3/16 inches thick. (See page 15.)
5. **Sheaves And Drums** - Inspect rope sheaves and drums for excessive wear. When the groove of a sheave or rope drum becomes worn excessively it should be replaced. Worn grooves on the drum or sheave can greatly reduce the useful life of the hoisting rope.
6. **Bearing Lubrication** - The motor, sheave and outer drum bearings are packed with grease at the factory and normally will not need to be lubricated. If conditions require, repack with grease as needed.
7. **Inspection Check List** - Fill out inspection check list at the back of this manual, sign, date and file for future reference.

FUNCTION TESTING AFTER REPAIR

After repair or replacement of parts, function test hoist by operating unloaded hoist into both upper and lower limits, first with slowest speed possible, then with increasing speeds up to maximum. Limit switch mechanisms must be adjusted so they will trip in sufficient time to prevent damage to any part of the hoisting arrangement. See instructions for adjustment of limit switches on page 10. Then test operation of hoist and brake by lifting 100% of rated load. (A normal load lifted may be substituted if no load bearing parts were altered.) If the gear train was disassembled, check the load brake per item 4 of the monthly inspection instructions. If hoist is equipped with a load limiting device, and load bearing parts have been altered, the first test load should be only 100% of rated load. Then test hoist per item 5 of annual inspection instructions. A written report of the test should be prepared by the person responsible and kept on file for future reference.



CAUTION

PRIOR TO TESTING ALL SUPPORTING STRUCTURES, ANCHORAGES, AND/OR SUSPENSIONS MUST BE APPROVED BY THE APPOINTED PERSON FOR THE TEST LOADS USED.

When Replacement Parts Are Needed, Order Only Yale® Factory Engineered Parts

Yale Hoisting Equipment

SECTION B

HOOK DIMENSIONS (EXCEPT FAW)

CAPACITY IN TONS	E (in.) NORMAL	E (in.) MAXIMUM
1/2	1 1/32	1 7/32
1	1 9/64	1 11/32
2	1 21/64	1 9/16
3	1 15/16	2 1/4
5	1 15/16	2 1/4
6	1 15/16	2 1/4
7 1/2	1 15/16	2 1/4
8	3 1/16	3 9/16
10	3 1/16	3 9/16
12	3 1/16	3 9/16
15	3 1/16	3 9/16
20	3 1/2	4 5/64
25	3 3/4	4 1/4
30	4 1/4	4 3/4

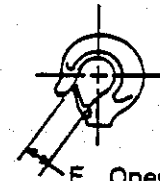

E Opening With Latch



WARNING

E OPENING WITH LATCH IF "E" EXCEEDS MAXIMUM SHOWN IN TABLE, REPLACE HOOK AND CHECK OTHER LOAD BEARING PARTS

HOOK DIMENSIONS (FAW)

CAPACITY IN TONS	E (in.) NORMAL	E (in.) MAXIMUM
5, 6 & 7 1/2	1 31/32	2 11/32
10	3 1/16	3 9/16
15 & 20	3 1/2	4 9/64
25	3 3/4	4 33/64
30	4 1/4	4 29/32

LOAD BRAKE DISC WEAR

MODEL	A DIMENSION	MAXIMUM WEAR ALLOWED
AW SERIES	3/16 (in.)	1/16 (in.)

NEW RATCHET AND BRAKE DISC ASSEMBLY

DISC BONDED TO RATCHET

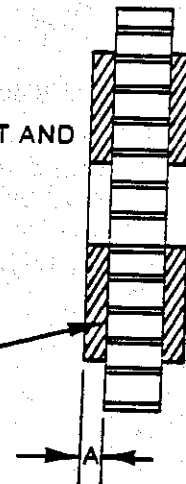

When Replacement Parts Are Needed, Order Only Yale® Factory Engineered Parts

SECTION B

**LUBRICATION
AW SERIES HOISTS**

GEARCASE BOX - SEE SECTION 1340

PART	LUBRICANT	LUBRICATION POINT	LUBRICATION INSTRUCTIONS	DRAIN POINT
Air Line Oil	SAE 10 Motor Oil	Filler Plug At Top Of Oiler	Drain moisture From Bottom Of Cavity & Fill With Oil	Drain cock at Bottom Of Oiler
Gear Case	Gulf Universal Tractor Fluid or Equal See Gearcase	Fill From Vent Hole On Top Of Gearcase	BAW-H4 1 QT. BAW-H3 & CAW-H4 3 PTS. CEW-H3 & DEW-H4 4 QTS. DEW-H3 & EEW-H3 8 QTS. QEW 8 QTS. REW 8 QTS. SEW 10 QTS.	SOCKET HEAD PLUG IN BTM OF GEARCASE
Hoist Motor Trolley Motor-If Applicable	Good Grade Of Non Detergent Motor Oil Below 30° F - Use S.A.E. 20 or 20W; 30° to 80° F - Use S.A.E. 30; Above 80° F-Use S.A.E. 40	Vent Plug At Top Of Motor Case	After Motor Has Been Idle Several Hours, Open Drain Cock At Bottom Of Motor And Allow All Accumulated Water to Drain Out. Open oil Cock At Side Of Motor Case. Add Oil Through Top Vent Plug Until Level is Even With Open Oil Cock (Or Sight Glass) Inside Of Motor Case	Drain Cock At Bottom Motor Case
Wire Rope	Keystone WRD-OW Spray Type Wire Rope Dressing, Or Other Prepared Cable Lubricant	Wire Rope	Light Coat Of Lubricant	

PLAIN AND HAND CHAIN OPERATED TROLLEYS

ALEMITE FITTINGS	GULF Crown Grease EP No. 2	BALL VALVE, OIL HOLES	Light Machine Oil
-------------------------	----------------------------	------------------------------	-------------------

RT, ST, WT AND TR SERIES TROLLEYS

PART	LUBRICANT	LUBRICATION POINT	LUBRICATION INSTRUCTIONS	DRAIN POINT
Gear Case	ST-Gulf Crown Grease EP No. 2 Or Equal; WT & TR. 140 EP Gear Oil: RT Shell Velvato Oil J82 or Equal.	Socket Head Plug In side of Gear Case	Fill Until Lubricant is Level With Hole	Socket Head Plug In Bottom Of Gear Case
Track Wheel Pinion & Gear Teeth	Moly Cote Grease	Pinion & Gear Teeth	Depending On Applications Light Coating Of Grease	

TT SERIES TROLLEYS

PART	LUBRICANT	LUBRICATION POINT	LUBRICATION INSTRUCTIONS	DRAIN POINT
Gear Case & Chain Case	Gulf Crown Grease EP No. 2 or Equal	Socket Head Plug On Side Of Chain Case	Fill Until Grease Is Level With Hole	Socket Head Plug In Bottom Of Gear Case

WIRE ROPE INSPECTION

All wire rope should be inspected once a month and a signed and dated inspection report maintained. The Inspection Check Lists at back of this manual can be used to record these inspections. Wire rope should be replaced if any of the following conditions are noted.

1. Twelve randomly distributed broken wires in one rope lay, or four broken wires in one strand in one rope lay.
2. Wear of one-third (1/3) of the original diameter of outside individual wires.
3. Kinking, crushing, bridging or any distortion of the wire rope structure.
4. Evidence of heat damage.



"Broken Wires"



"Kinked"

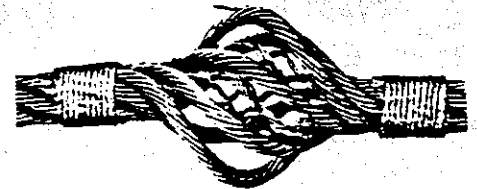

Bird Cage

5. Reductions from nominal diameter of more than the following values.

New Rope Diameter	Maximum Reduction
5/16 Inch and under	1/64 Inch
3/8 Inch Thru 1/2 Inch	1/32 Inch
9/16 Inch Thru 3/4 Inch	3/64 Inch
7/8 Inch Thru 1 1/8 Inch	1/16 Inch

6. Rope sockets should be inspected for broken wires. If broken wires are noted, the rope should be replaced.



CAUTION

REPLACEMENT WIRE ROPE SHOULD BE THE SAME SIZE, GRADE AND CONSTRUCTION AS THE ORIGINAL WIRE ROPE. BEFORE REPLACING WIRE ROPE, READ PROCEDURE ON PAGE 19. AFTER WIRE ROPE REPLACEMENT CHECK FOR PROPER LIMIT SWITCH OPERATION. (SEE PAGES 10.)



CAUTION

ROPE PILE-UP ON THE HOISTING DRUM WILL SEVERELY DAMAGE THE HOISTING ROPE. IF THIS CONDITION IS NOTED THE HOISTING ROPE SHOULD BE INSPECTED ACCORDING TO THE ABOVE PARAGRAPH ON WIRE ROPE INSPECTION. IF DAMAGED ROPE IS FOUND, CHECK DRUM AND FRAME MEMBERS FOR DAMAGE.

When Replacement Parts Are Needed, Order Only Yale® Factory Engineered Parts

SECTION B

HOW TO MEASURE WIRE ROPE

The correct diameter of a wire rope is the diameter of a circumscribed circle which will enclose all the strands. It is the largest cross-sectional measurement as illustrated below. The measurement should be made carefully with calipers. The illustrations below show the correct and incorrect method of measuring the diameter of wire rope.

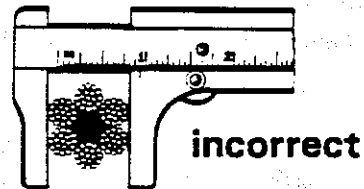
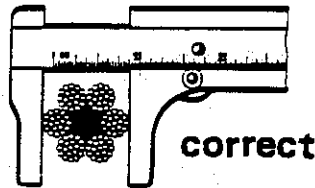
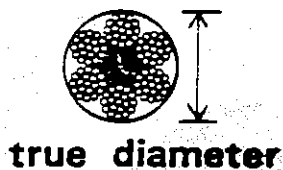

PROCEDURE FOR REEVING WIRE ROPE ON DRUM

DOUBLE REEVED UNITS

NOTE TRAVELING NUT LIMIT SWITCH MUST BE PRESET BEFORE REEVING, PER STEPS (a) THRU (e) ON PAGE 10 AND RE-ADJUSTED PER STEPS (f) THRU (n) AFTER REEVING.

1. Anchor the rope in the drum on one side. Install rope retainer.
2. Stretch out rope to make sure there are no twists or kinks.
3. Reeve the free end of the rope through the bottom block and all sheaves. (See page 20 & 21.)
4. Anchor the free end of the rope in the other side of the drum. Install rope retainer.
5. Push the "UP" button to reeve both sides of the drum, making sure there is enough force on the rope to insure proper reeving in all drum grooves.

NOTE WHEN THE BOTTOM BLOCK IS RAISED TO THE UPPER LIMIT THE BLOCK SHOULD BE AT THE MID-POINT OF THE UNGROOVED PORTION OF THE DRUM AND EVEN WITH THE IDLER SHEAVE. IF THIS IS NOT SO, THE UNIT IS REEVED INCORRECTLY.

When Replacement Parts Are Needed, Order Only Yale® Factory Engineered Parts

SINGLE REEVED UNITS

1. Anchor the rope in the drum. Install rope retainer.
2. Stretch out rope to make sure there are no twists or kinks.
3. Reeve the free end of the rope through the bottom block. (see next page.)
4. Attach the dead end of the rope to the suspension frame.
5. Push the "UP" button to reeve the drum making sure there is enough force on the rope to insure proper reeving in all drum grooves.



CAUTION

ALL UNITS MUST HAVE A MINIMUM OF 2 WRAPS OF WIRE ROPE ON THE DRUM WHEN THE BOTTOM BLOCK IS IN THE LOWEST POSITION, OR AT LEAST 1 WRAP WHEN THE UNIT IS EQUIPPED WITH A LOWER LIMIT SWITCH.

REEVING TYPES

Yale powered wire rope hoists and winches are reeved in various ways to gain desired advantages. Proper reeving insures maximum life of the hoist drum, wire rope and bottom block assembly while obtaining the best characteristics of capacity, lift and speed for the basic unit.

Reeving is either "single" or "double." i.e. one or two ropes coming from the drum. Standard headroom hoists are single reeved; close headroom hoists are double reeved. Part designates the mechanical use of each rope coming from the drum.

The table and drawings pictured on the next page show the characteristics of each principal method of reeving.

The advantages of single reeved units are fewer ropes and longer lifts from comparable units. Advantages of double reeved units include minimum lateral hook drift (keeping load in the same approximate position in relation to the drum and beam) and a lower hoist headroom requirement.

When Replacement Parts Are Needed, Order Only Yale® Factory Engineered Parts

SECTION B

REEVING TYPES

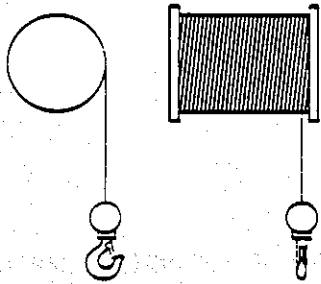

1 part single
S1

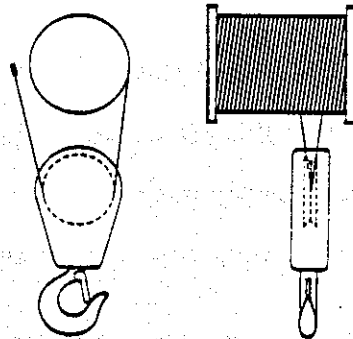

2 part single
S2

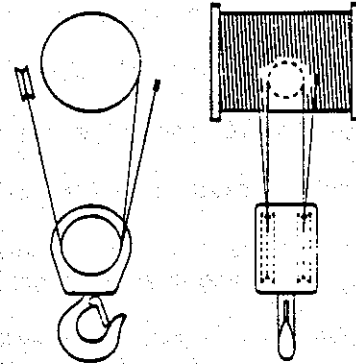

4 part single
S4

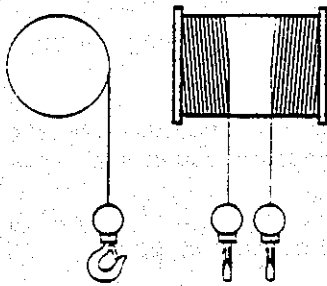

twin rope (1 part double)
D1

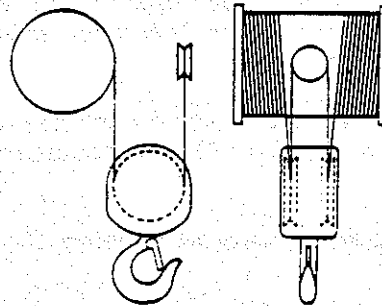

2 part double
D2

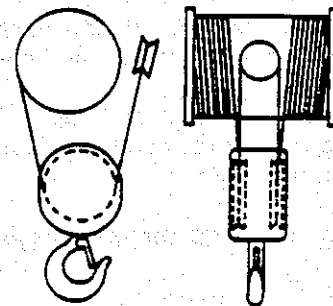

2 part double
P2

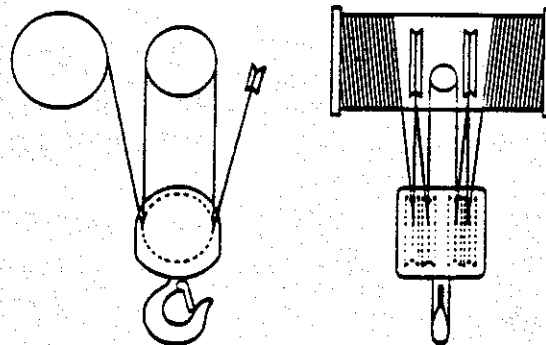

4 part double
D4

When Replacement Parts Are Needed, Order Only Yale® Factory Engineered Parts

REEVING TYPES

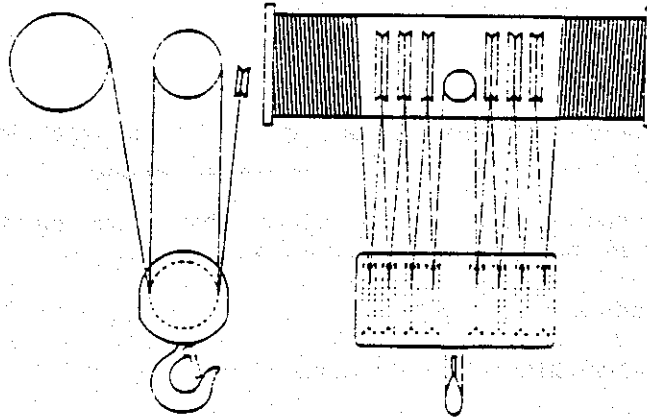

8 part double
D8

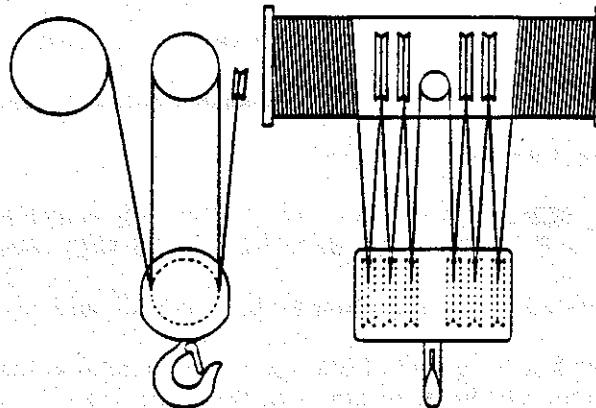

6 part double
D6

When Replacement Parts Are Needed, Order Only Yale® Factory Engineered Parts

SECTION B

DISASSEMBLY (For all chassis except EAW - X & FAW -)



CAUTION:

BEFORE DOING MAINTENANCE WORK ON THIS HOIST, READ THE FOLLOWING INSTRUCTIONS THOROUGHLY. REFER TO THE REPLACEMENT PARTS SECTION FOR PARTS IDENTIFICATION.

To completely disassemble the hoist, follow the disassembly procedures in the order listed.

To disassemble any one specific part of the hoist, follow the instructions for that specific section.

DISASSEMBLY

I. Remove Hoist Rope, Bottom Block Or Bottom Hook

A. Standard Headroom Hoist

1. Remove or re-adjust traveling nut or geared limit to negate lower limit [see instructions (a) thru (f) on page 10.]
2. Operate hoist in down direction until no cable remains on the drum. Remove rope retainers and pull rope sockets from the drum.
3. Remove power from the hoist.
4. Disassemble bottom block and remove hoist rope.
5. Remove limit switch weight from the hoist cable.
6. Remove pin holding the cable in the hoist frame.

B. Low Headroom Hoist

1. Follow procedures in I.A - 1, 2 and 3.
2. Remove pin holding equalizer sheave yoke in hoist frame.
3. Remove axle holding the sheave in the yoke and remove cable.

II. Remove motor brake (Direct Acting)

! CAUTION REMOVE AIR PRESSURE FROM THE HOIST BY DISCONNECTING THE AIR SUPPLY LINE BEFORE ATTEMPTING SERVICE OR REPAIR.

1. Disconnect air line to brake. Remove cover screws and cover.
2. Remove three hex head bolts from taper lock bushing at the end of brake. Re-insert bolts in the threaded holes in the bushing flange and tighten them. Remove the bushing and brake from shaft.

When Replacement Parts Are Needed, Order Only Yale® Factory Engineered Parts

DISASSEMBLY (Continued) For all chassis except EAW - X & FAW -

III. Remove Gearcase And Drive Shaft

1. If possible, run hoist in down direction and clear all rope from the hoist drum.
2. Follow procedure in II to remove motor brake.
3. Before removing gearcase, the hoist rope drum must be securely restrained within the suspension frame. (Note that the hoist motor does not have to be removed at this time but must be removed before the gearcase can be reassembled to the hoist.)
4. Pry the gearcase from the frame sideplate.

The gearcase assemblies can be very heavy. If possible, it is best to support their weight prior to removal.

IV. Remove Hoist Motor, Motor Adapter

1. If possible, run hoist in down direction and clear all rope from the hoist drum.
2. Remove air pressure from the hoist.
3. Disconnect tubing from motor.
4. Remove four bolts and lockwashers holding motor to motor adapter.
5. Pry the motor from the motor adapter.
6. Before removing the motor adapter the hoist drum must be securely restrained within the suspension frame.
7. Remove the four bolts and lockwashers holding the motor adapter to the frame sideplate.
8. Pry the motor adapter from the frame sideplate.

The motors and motor adapters can be very heavy. If possible, it is best to support their weight prior to removal.

V. Remove Hoist Rope Drum

1. Follow procedures in I, II, III and IV to remove gearcase and drive shaft, motor, and motor adapter.
2. Remove rope drum from suspension frame.

When Replacement Parts Are Needed, Order Only Yale[®] Factory Engineered Parts

SECTION B

DISASSEMBLY (Continued) For all chassis except EAW - X & FAW -

VI. Remove Limit Switch, Traveling Nut Or Geared

A. Geared upper and lower limit switch

1. Disconnect the air supply from hoist.
2. Remove the cover from the limit switch and disconnect the tubing. Tag the tubing so that it can be reconnected correctly.
3. Remove the three bolts and lockwashers that hold the limit switch assembly to the gearcase. Remove the limit switch assembly from the gearcase.
4. Refer to section 1420/30 if further dis-assembly of the limit switch is necessary.

B. Lever operated upper limit switch

1. Disconnect the air supply from hoist.
2. Remove the bolts holding the limit switch bracket to the hoist and remove the limit switch assembly.
3. Loosen the clamping screw holding the hub on the limit switch shaft and remove the hub and lever assembly. Note its position carefully so it can be re-installed correctly.
4. Remove the screws holding the limit switch to the bracket.
5. Remove the limit cover and disconnect the tubing. Tag the tubing so that it can be reconnected correctly.

C. Weight operated upper limit switch

1. Disconnect the air supply from the hoist.
2. Remove the clamping screws holding operating weight around the wire rope and remove the weight.
3. Remove bolts holding the limit switch bracket to the hoist and remove the limit switch assembly.
4. Loosen the clamping screw holding the hub on the limit switch shaft and remove the hub and lever assembly. Note its position carefully so it can be re-installed correctly.
5. Remove the screws holding the limit switch valve to the bracket.
6. Remove the limit cover and disconnect the tubing. Tag the tubing so that it can be reconnected correctly.

When Replacement Parts Are Needed, Order Only Yale® Factory Engineered Parts

DISASSEMBLY (Continued) For all chassis except EAW - X & FAW -

VII. Remove Load Brake Assembly

1. Follow procedures in I and II for removing motor brake.
2. Remove drain plug at the bottom of gearcase cover and drain the oil into suitable container. **DO NOT REMOVE PAWL STOP PLUG AT THIS TIME.**
3. Remove nuts, bolts, and lockwashers from the gearcase - gearcase cover flange.
4. Pry gearcase cover away from gearcase.
5. Lift out intermediate gear and slow speed pinion shaft.
6. Cover the ratchet pawl with a rag to prevent losing the retainers which are spring loaded.
7. Remove pawl stop and/or spring assembly.
8. Rotate the load brake assembly until the pawl clears the load brake and the retainers pop out of the pawl.
9. Remove the retainers and spring.
10. Remove pawl pin and pawl. (Note that the D chassis has a cotter pin through the pawl and pin. It will be necessary to remove this cotter pin first.)
11. Lift the load brake assembly out of the gearcase cover.
12. See Section 1340 for load brake disassembly instructions;

When Replacement Parts Are Needed, Order Only Yale® Factory Engineered Parts

SECTION B

REASSEMBLY (For all chassis except EAW - X & FAW - .).

The assembly sequence is basically the reverse of the disassembly sequence previously described. The following special instructions should be observed during reassembly:

1. Inspect the **drum support bearing** in the end of the hoist drum. Replace if damaged.

Be sure the splines in the drum are free of prime paint or other material which would interfere with installation. Lubricate these splines before assembly to prevent wear.

The hoist drum must be centered between the large bores in the suspension frame sideplates. (Suspend the drum in a sling or support it on blocks.)
2. The **motor adapter** (with hoist motor removed) must be installed **BEFORE** the gearcase assembly. Once installed the motor adapter supports and centers one end of the hoist drum.
3. Before **gearcase** is assembled all internal parts should be inspected for damage or excessive wear. Replace parts as required.

Apply a light coating of number 1 or 2 grade Permatex to the flange faces of the gearcase and gearcase cover. (This is also applied to the traveling nut or geared limit switch drive unit if it has been removed.)
4. Inspect the **universal joints** on the drive shaft. Replace if damaged. Fasten the drive shaft assembly to the gearcase pinion shaft.

Pilot the drive shaft assembly through the suspension frame bore and drum shaft splines. Before the gearcase assembly is too close to the suspension frame, the loose end of the drive shaft must be lifted to go into the motor adapter bore (a length of small diameter pipe can be used for this.)
5. Inspect the **motor shaft spline** for nicks or other damage which would interfere with assembly into drive shaft yoke. Correct damage if necessary.

When piloting the motor onto the motor adapter, rotating the gearcase pinion (where the motor brake mounts) can help to line up the splines.
6. Be sure the **motor brake** is properly adjusted before it is installed on the gearcase. See Section 1351.

When Replacement Parts Are Needed, Order Only Yale® Factory Engineered Parts

Yale Hoisting Equipment

SECTION B

DISASSEMBLY OF HOIST (EAW - X & FAW -)



CAUTION:

BEFORE DOING MAINTENANCE WORK ON THIS HOIST, READ THE FOLLOWING INSTRUCTIONS THOROUGHLY. REFER TO THE REPLACEMENT PARTS SECTION FOR PARTS IDENTIFICATION.

To completely disassemble the hoist, follow the disassembly procedures in the order listed.

To disassemble any one specific part of the hoist, follow the instructions for that specific section.

I. TO REMOVE WIRE ROPE AND BOTTOM BLOCK

Operate push button pendant in lowering direction until lower limit switch stops hoist motor. Turn off power feed line to hoist. Remove screws from cover of traveling nut or geared type limit switch. Back cam or traveling nut away from switch that has made contact. Apply power to hoist. Operate push button in down mode to the point where no wraps of wire rope remain on hoist drum. Remove rope socket or sockets from hoist drum. Remove anchor pin from suspension frame if hoist has single reeving drum.



CAUTION:

BEFORE CONTINUING WITH THE DISASSEMBLY PROCEDURES, REMOVE AIR PRESSURE TO THE HOIST BY DISCONNECTING THE AIR SUPPLY LINE. REMOVE YOKE (S) AND/OR IDLER SHEAVE PIN (S) TO FREE WIRE ROPE, SHEAVE (S) AND BOTTOM BLOCK FROM HOIST.



CAUTION:

NEVER DISASSEMBLE THE HOIST IN DIRTY SURROUNDINGS, NOR ALLOW DIRT, GRIT OR ANY OTHER FOREIGN MATERIAL TO GET ON THE WORKING AREAS OF THESE PARTS.

II. TO DRAIN OIL FROM HOIST

Remove the drain plug from bottom of gearcase. See lubrication chart page 16 when replacing oil in gearcase.

III. TO REMOVE THE MOTOR BRAKE ASSEMBLY (Solenoid Actuated)

1. **Disconnect air line to brake. Remove cover screws and cover.**
2. **Remove three hex head bolts from taper lock bushing at the end of brake. Re-insert bolts in the threaded holes in the bushing flange and tighten them. Remove the bushing and brake from shaft.**

When Replacement Parts Are Needed, Order Only Yale® Factory Engineered Parts

SECTION B

DISASSEMBLY (Continued) (EAW - X & FAW -)

IV. TO REMOVE BRAKE ADAPTER

Remove three hex head bolts.

V. TO REMOVE COVER PLATES FROM GEARBOX

Remove eighteen hex head screws from each cover to be removed.

VI. TO REMOVE HOIST MOTOR

Disconnect all motor hoses from the fittings. Using an adequate sling, prepare to mobilize weight of motor. Remove four 1 1/8 hex head bolts, and pull motor outward.

VII. TO REMOVE GEAR BOX FROM SUSPENSION FRAME

Prepare to mobilize weight of wire rope drum and gearbox. Remove three 1 inch hex head bolts. Pull outward on gearbox until drive shaft is out of hoist.

NOTE: To reassemble gearbox and drive shaft, drive shaft must be supported and aligned with motor adapter and motor shaft hole.

VIII. TO REMOVE DRIVE SHAFT

Unscrew four 5/16 inch hex head bolts from spider and bearing assembly on gearcase end, and unscrew 9/16 inch hex head bolts from end of driving pinion.

IX. TO DISASSEMBLE GEARCASE

- (a) Remove eight 1/4 inch hex head screws from the output shaft bearing cover and retainer.
- (b) Remove large retaining ring from the smaller end of output shaft which is inside the gearcase. This will allow the output shaft, driving pinion and third reduction gear to be removed from gearcase.
- (c) Remove traveling nut or geared type limit switch by removing three 5/16 inch hex head screws. Switch can now be lifted off.
- (d) Remove third reduction pinion and second reduction gear. This is done by removing six 1/4 inch hex head screws from third reduction pinion, bearing, and retainer cover. Cover, bearings, pinion, gear and spacer can now be removed. See gear train illustration in parts section 1340 of this manual.

When Replacement Parts Are Needed, Order Only Yale® Factory Engineered Parts

DISASSEMBLY (Continued) (EAW - X & FAW -)

- (e) Remove sprag clutch. This can be done by removing six 1/2 inch hex head bolts from end of sprag clutch inner race which is outside the gearcase. Inner race, gear and spacer can now be removed by applying pressure to the smaller end of inner race inside the gearcase.
- (f) Remove load brake assembly, first reduction gear and second reduction pinion. This can be done by removing 1/4 inch hex screws from plate outside gearcase. This will free bearing retainer cover plate. To remove pinion, rotate high speed gear to the left, holding pinion. This will push the pinion out of load brake assembly. The pinion may now be pulled the rest of the way out of load brake. Bearings, discs, load brake gears and high speed gears can now be removed from gearcase.

NOTE: To remove bearing and seal from output shaft, remove retainer snap ring.

X. TO DISASSEMBLE MOTOR ADAPTER FROM SUSPENSION FRAME

Prepare to mobilize weight of wire rope drum and motor adapter. Remove three 1 inch hex head bolts and nuts. This will allow adapter to be pulled away from frame and drum.

XI. TO REMOVE WIRE ROPE DRUM FROM HOIST

Motor adapter and gearcase must be removed from the suspension frame before drum can be removed. (See steps VII and X.)



CAUTION: DRUM IS HEAVY AND MUST BE SUSPENDED BEFORE REMOVING.

XII. TO REMOVE CONTROLS, VALVES AND PENDANT

Remove the air supply from hoist. Disconnect and tag all control pendant tubing.

XIII. TO DISASSEMBLE BOTTOM BLOCK

Use normal disassembly procedures and refer to applicable bottom block parts pages to remove hook, sheaves, etc. from bottom block.

When Replacement Parts Are Needed, Order Only Yale® Factory Engineered Parts

SECTION B

ASSEMBLY OF HOIST

TO REASSEMBLE HOIST (EAW - X & FAW -)

Reverse preceding disassembly procedures. Make sure all parts are properly adjusted and lubricated per applicable instructions. Replace bearings and gaskets if they have been damaged. (See chart page 16 for type of oil when refilling.)

NOTE: To assemble load brake, the high speed gear, inner bearing race and spacer brake must be aligned. If possible, the inboard side of the gearcase should be laid flat on a table during reassembly. This will make it easier to align holes. If gear box is standing upright, the housing must be held in position to assemble the load brake.

 **CAUTION:** IF THE LOAD BRAKE IS DISASSEMBLED WITH THE GEAR BOX ON THE HOIST, ROTATING OF DRUM MUST BE PREVENTED.

NOTE: After assembly the hoist must be function tested in accordance with instructions on page 14 of this manual.

When Replacement Parts Are Needed, Order Only Yale® Factory Engineered Parts

TROUBLE SHOOTING (For all chassis except EAW - X & FAW -)

UNIT NOISY

Possible Cause	Remedy
(a) Nicked gears.	(a) Examine teeth for nicks and burrs. Remove with honing stone, replace if teeth are severely damaged.
(b) No oil.	(b) Fill to oil level hole.
(c) Defective bearing.	(c) Replace.

OIL SEEP-AGE

Possible Cause	Remedy
(a) Fill plug loose.	(a) Tighten.
(b) Gearcase cover loose.	(b) Tighten screws.
(c) No hole in vent plug.	(c) Replace with vent plug.
(d) Defective seals.	(d) Check lips of seal for worn or rough edges. Replace as necessary.

LOAD DRIFTS OR DROPS

Possible Cause	Remedy
(a) Load brake discs worn or glazed.	(a) If brake discs are not worn to less than 1/8 inch thick, rough brake disc surface (and surfaces that contact discs) with coarse emery cloth. Wash thoroughly and reassemble. If not effective or if discs are less than 1/8 inch thick, replace ratchet and disc assembly.
(b) Load brake pawl not operating.	(b) Check for tight fitting pawl or retainer tight in pawl. Replace if necessary. (See Section 1340.)
(c) Load brake not closing.	(c) Check for burrs on thread of intermediate pinion or high speed gear. Hone or replace. Mating parts must thread easily.
(d) Ratchet installed backwards.	(d) Turn around.
(e) Motor brake slipping.	(e) Adjust brake. Check for oil on brake discs.
(f) Motor brake not closing.	(f) Adjust for proper clearance. (See Section 1351).
(g) Retainer or retainer spring, missing, or broken.	(g) Replace.

When Replacement Parts Are Needed, Order Only Yale® Factory Engineered Parts

SECTION B

TROUBLE SHOOTING (Continued) For all chassis except EAW - X & FAW

HOOK DOES NOT RESPOND TO CONTROLS

Possible Cause	Remedy
(a) Air Source.	(a) Check regulators and valves.
(b) Motor brake not opening.	(b) Check air line to the brake. If brake will not disengage when the minimum recommended pressure is applied, repair or replace brake. (See Section 1351)

HOOK LOWERS BUT WILL NOT RAISE

Possible Cause	Remedy
(a) Excessive load.	(a) Reduce loading to capacity limit on the hoist nameplate.
(b) Upper Limit Switch Malfunction.	(b) Check per instructions listed on limit switch pages.
(c) Traveling Nut Limit Switch Malfunction.	(c) Check per instructions listed on limit switch pages. The hook may not have moved far enough to reset the upper limit valve.

HOOK RAISES BUT WILL NOT LOWER

Possible Cause	Remedy
(a) Traveling Nut Limit Switch Malfunction.	(a) Check per instructions listed on limit switch pages. Hook may not have moved far enough to reset the lower limit valve.

SLUGGISH OPERATION

(a) Dirty Air Motor.	(a) Flush motor with kerosene in a well ventilated area. Dis-connect air lines and muffler. Warning--keep face away from exhaust air. Clean and relubricate motor chamber and muffler.
----------------------	----------------------------------------------------------------------------------------------------------------------------------------------------------------------------------------

When Replacement Parts Are Needed, Order Only Yale® Factory Engineered Parts

TROUBLE SHOOTING (Continued) (EAW - X & FAW -)

UNIT NOISY

Possible Cause	Remedy
(a) Nicked gears.	(a) Examine teeth for nicks and burrs. Remove with honing stone, replace if teeth are severely damaged.
(b) No oil.	(b) Fill to oil level hole.
(c) Defective bearing.	(c) Replace.
(d) Slow speed gear upside down.	(d) Turn over. Chamfer on splined hole must face gearcase.

OIL SEEP-AGE

Possible Cause	Remedy
(a) Fill plug loose.	(a) Tighten.
(b) Gearcase cover loose.	(b) Tighten screws.
(c) No hole in vent plug.	(c) Replace with vent plug.
(d) Defective seals.	(d) Check lips of seal for worn or rough edges.

LOAD DRIFTS OR DROPS

Possible Cause	Remedy
(a) Load brake discs worn or glazed.	(a) If brake discs are not worn to less than 1/8 inch thick, rough brake disc surface (and surfaces that contact discs) with coarse emery cloth. Wash thoroughly and reassemble. If not effective or if discs are less than 1/8 inch thick, replace gear and disc assembly.
(b) One-way (Sprag) clutch not operating.	(b) Repair or replace clutch (see Section 1340).
(c) Load brake not closing.	(c) Check for burrs on thread of intermediate pinion or high speed gear. Hone or replace. Mating parts must thread easily.
(d) Motor brake slipping.	(d) Replace brake discs. Check for oil on discs.

When Replacement Parts Are Needed, Order Only Yale® Factory Engineered Parts

SECTION B
TROUBLE SHOOTING (Continued) (EAW - X & FAW -)

HOOK DOES NOT RESPOND TO CONTROLS

Possible Cause	Remedy
(a) Air source.	(a) Check regulators and valves.
(b) Motor brake not opening	(b) Check air line to the brake. If brake will not disengage when the minimum recommended pressure is applied, repair or replace brake. (See Section 1351.)

HOOK LOWERS BUT WILL NOT RAISE

Possible Cause	Remedy
(a) Excessive load.	(a) Reduce loading to capacity limit on the hoist nameplate.
(b) Upper Limit Switch Malfunction.	(b) Check per instructions listed on limit switch pages.
(c) Traveling Nut Limit Switch Malfunction.	(c) Check per instructions listed on limit switch pages. The hook may not have moved far enough to reset the upper limit valve.

HOOK RAISES BUT WILL NOT LOWER

Possible Cause	Remedy
(a) Traveling Nut Limit Switch Malfunction	(a) Check per instructions listed on limit switch pages. Hook may not have moved far enough to reset the lower limit valve.

SLUGGISH OPERATION

(a) Dirty air motor.	(a) Flush motor with kerosene in a well ventilated area. Disconnect air lines and muffler. Warning - - keep face away from exhaust air. Clean and relubricate motor chamber and muffler.
----------------------	------------------------------------------------------------------------------------------------------------------------------------------------------------------------------------------

When Replacement Parts Are Needed, Order Only Yale® Factory Engineered Parts

SECTION B

**SCHEMATIC
AIR FLOW DIAGRAM
FOR PENDANT CONTROL**

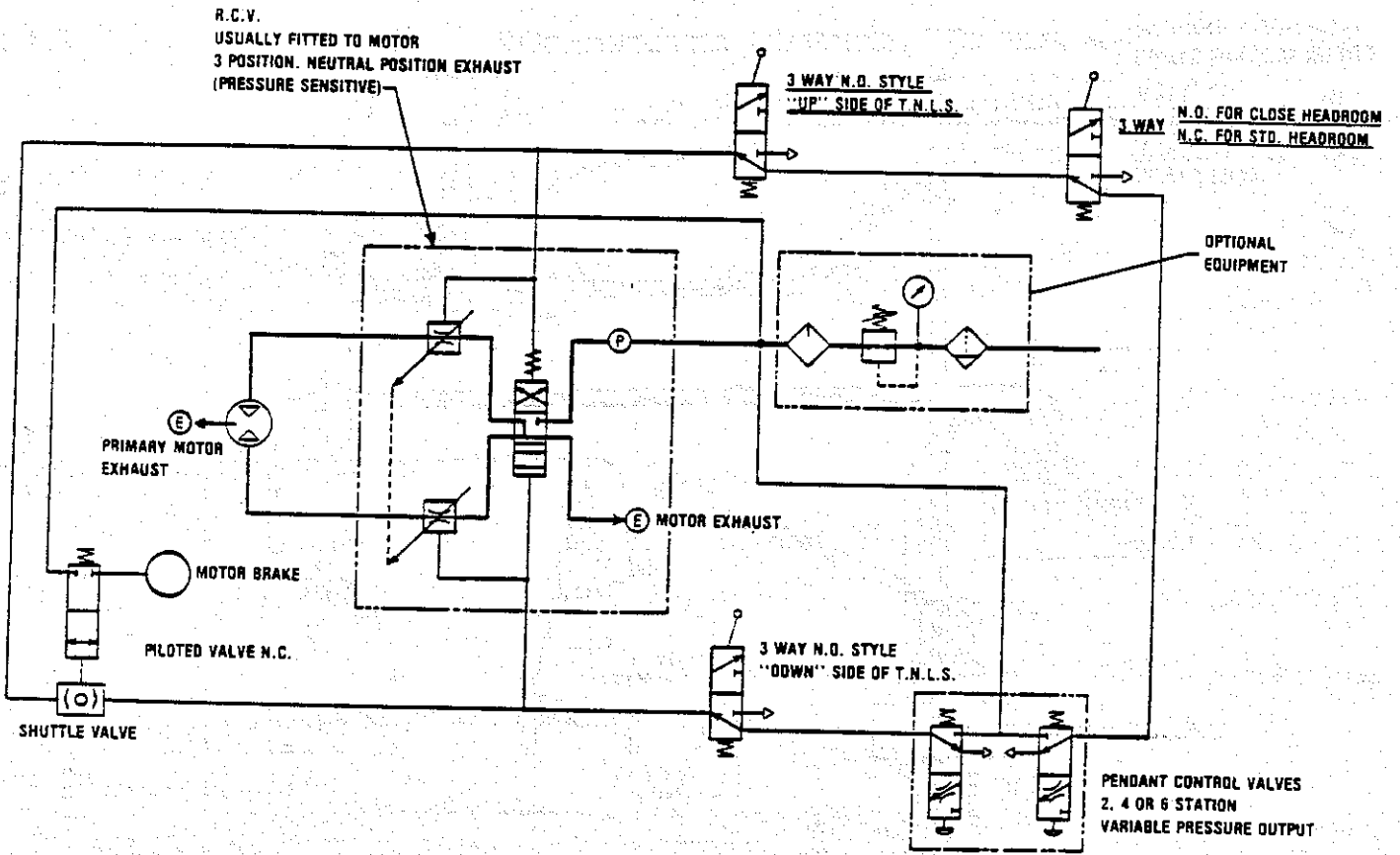

When Replacement Parts Are Needed, Order Only Yale® Factory Engineered Parts

USER INFORMATION PAGE

REFER TO PARTS LIST IN FRONT COVER FOR COMPONENT NUMBER

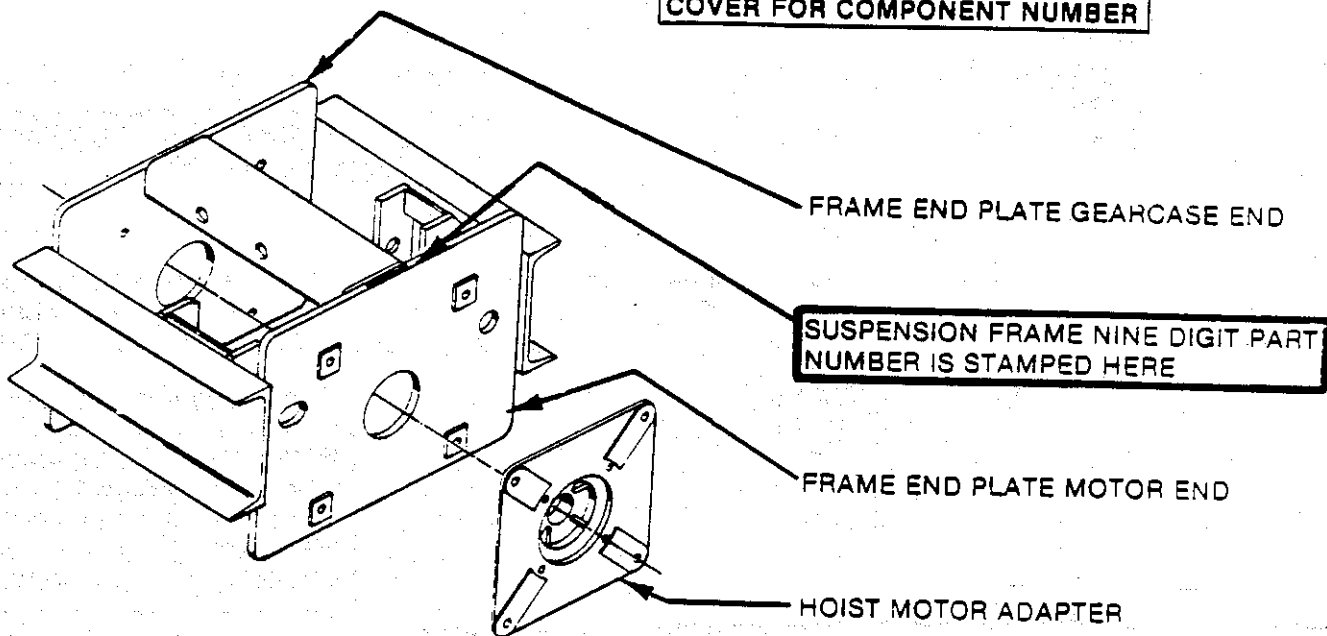

The suspension frame illustrated above may not exactly represent the actual appearance of the frame. However, it is typical.

IMPORTANT: WHEN ORDERING REPLACEMENT SUSPENSION FRAME USE NINE DIGIT NUMBER STAMPED ON SUSPENSION FRAME. IF NUMBER IS NOT LEGIBLE, IT IS IMPERATIVE THAT COMPLETE MODEL AND SERIAL NUMBER OF HOIST BE FURNISHED. THIS INFORMATION IS STAMPED ON HOIST NAME PLATE

FORM NO. 165-903-101

When Replacement Parts Are Needed, Order Only Yale[®] Factory Engineered Parts
SEPTEMBER 1984

SECTION 1120
DRUM

REFER TO PARTS LIST IN FRONT
COVER FOR COMPONENT NUMBER

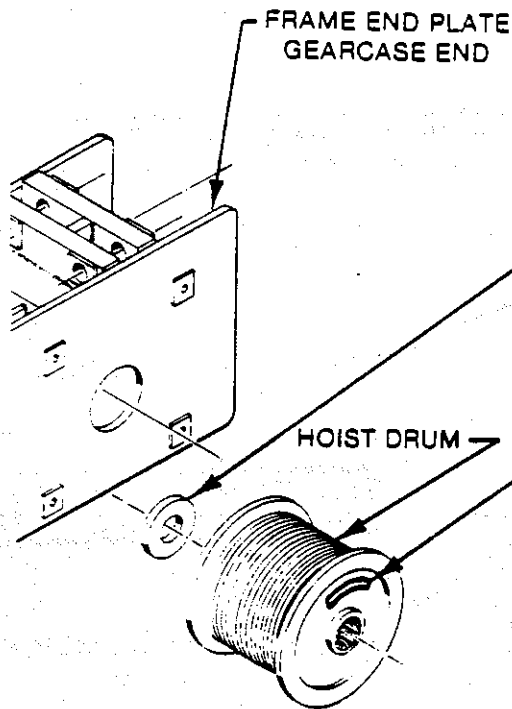

DRUM BEARING

PART NUMBER	CHASSIS
5025079-02	B & C
6401629-01	D & E

HOIST DRUM NINE DIGIT PART NUMBER
IS STAMPED HERE

ROPE RETAINER BRACKET ASM.
B, C, D & E CHASSIS
ROPE SIZE 3/16 in. THRU 3/4 in.

6439342-00 ASSEMBLY INCLUDES

PART NBR.	DESCRIPTION	QTY.
6466571-00	BRACKET	1
0597115-00	3/8 - 16 - 3/4 lg.	1
0150264-00	LOCKWASHER	1

Yale

Capacity, tons 5

Speed, rpm 30

Model FEW10-51CB46D2

Serial AB77867

Volts 460 Phase 3 Hz 60

Min. Circuit Amperity _____

Max. Fuse Rating _____

Order No. W122345

H4 THIS HOIST IS DESIGNED TO MEET THE REQUIREMENTS FOR THE CLASS AND SERVICE AND IS APPROVED FOR STANDARD OR HEAVY DUTY APPLICATIONS WHERE THE TOTAL RUNNING TIME OF THE HOIST DOES NOT EXCEED 15% OF THE WORK PERIOD.

F.T.O. Edison Corporation 11308-U.S.A. Forrest City, AR

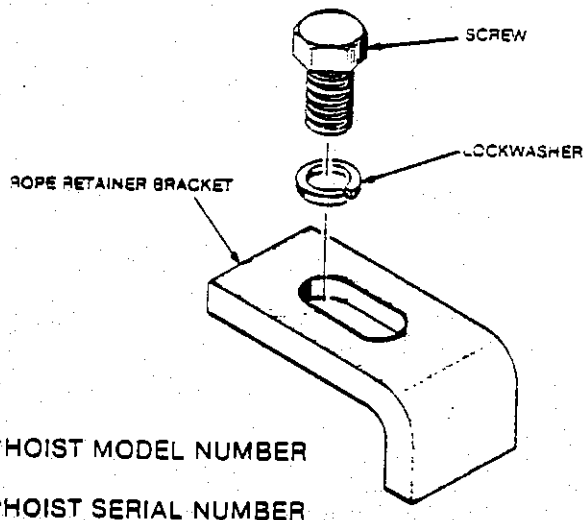

HOIST NAME PLATE

The nameplate illustrated above may not exactly represent the actual appearance of the hoist name plate. However, it is typical.

IMPORTANT: WHEN ORDERING REPLACEMENT HOIST DRUM USE NINE DIGIT NUMBER STAMPED ON HOIST DRUM. IF NUMBER IS NOT LEGIBLE, IT IS IMPERATIVE THAT COMPLETE MODEL AND SERIAL NUMBER OF HOIST BE FURNISHED. THIS INFORMATION IS STAMPED ON HOIST NAME PLATE

FORM NO. 165-903-101

When Replacement Parts Are Needed, Order Only Yale[®] Factory Engineered Parts
EWIAW SERIES

Yale Hoisting Equipment

SECTION 1315
DRIVE SHAFT
&
SPIDER ASM.

REFER TO PARTS LIST IN FRONT
COVER FOR COMPONENT NUMBER

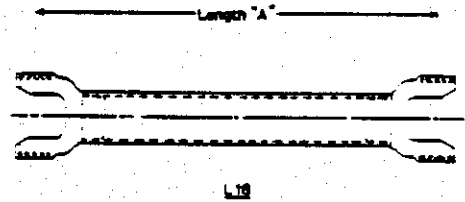
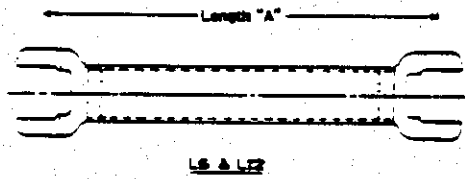

SPIDER



When Replacement Parts Are Needed, Order Only Yale® Factory Engineered Parts
SEPTEMBER 1984

EW/AW SERIES

GEAR TRAIN AND LOAD BRAKE ASSEMBLY

OPERATION DESCRIPTION AND MAINTENANCE OF YALE LOAD BRAKE

PURPOSE

The main purpose of the Yale "Weston Screw And Disc Type" load brake is to control the lowering speed of the hoist. The secondary purpose is to act as an auxiliary brake.

OPERATION

The load brake functions regardless of whether the current is on or off when lowering. When the current is off the load pulls in a counter-clockwise direction on the slow speed gear and screws the brake up tight locking all the parts of the load brake together. A pawl engages the ratchet and disc assembly holding the load stationary when the pull is in this direction. The greater the load, the more definite the locking action.

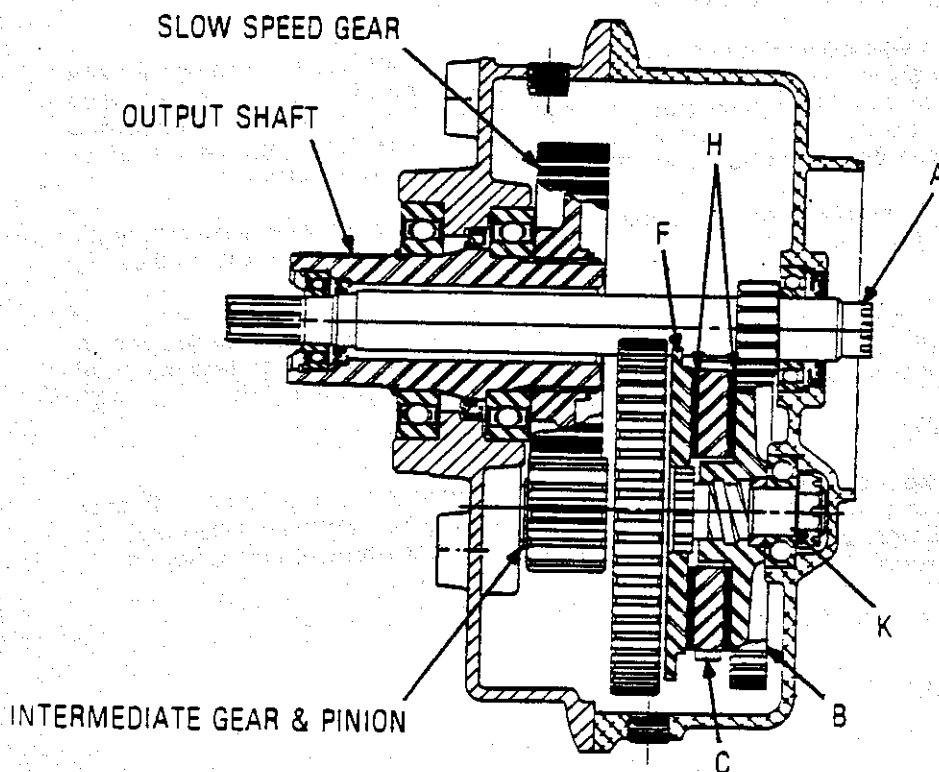

ROTATION WILL BE CLOCKWISE
WHEN LOOKING INTO THE GEARING
END TOWARD THE MOTOR END.

FIGURE 1

YA - 0246

When hoisting, running in the up direction, power from the motor is applied through the driving pinion A to the high speed gear B. This gear, with its threaded hub, screws clockwise and all of the brake parts become tight and move as a unit in the clockwise direction.

FORM NO. 165-904-009

When Replacement Parts Are Needed, Order Only Yale® Factory Engineered Parts

AUGUST 1984

SECTION 1340

GEARING & LOAD BRAKE

GEAR TRAIN AND BRAKE ASSEMBLY EW SERIES

Movement is free because the ratchet gear and disc assembly C is moving clockwise and it can rotate without the teeth engaging the pawl D. In this direction of rotation, the pawl is held away from the ratchet by a spring loaded friction button E which is part of the pawl assembly and presses outward simultaneously on the reaction disc F and high speed gear B. As the load brake rotates in this direction it tends to drag the spring loaded button with it causing the pawl to ride over the ratchet teeth ready to catch and hold the pawl the instant the load starts to lower. The load brake is completely locked when operating in this direction and there is no loss of power due to friction in the load brake.

When lowering, the driving pinion reverses the direction of the high speed gear, turning it counter-clockwise. This unscrews the high speed gear and loosens the load brake. At the same time the load is pulling through the gear train in a clockwise direction on the intermediate pinion K trying to tighten the brake. This interaction is constantly going on when the hoist is lowering. In a smoothly operating load brake the motor uses about one-third to one-half of its rated horsepower to drive the load down by keeping a satisfactory adjustment on the brake between the open and closed position. This operation must be just fast enough to keep the pull of the load from getting ahead and closing the brake. The load is always under control as it is the action of the motor which lowers it while the weight of the load always works to close the brake.

In this lowering operation friction slows the load as the brake is just slightly open. The ratchet and disc assembly is held stationary by the ratchet pawl, while high speed gear revolves. The brake discs H are bonded to the ratchet to form the ratchet and disc assembly C. The friction of the high speed gear B and reaction disc F against the stationary ratchet and disc assembly, with the aid of oil lubrication produces a positive braking action permitting easy and gradual lowering.

The instant the down button is released, the high speed gear becomes stationary because the motor brake hold the driving pinion stationary, and the pull of the load closes the brake as it is held by the ratchet pawl.

When the hoist lowers without a load, the high speed gear opens the brake and drives the hook down directly through the gear train. Only the friction of the normally operating gears interferes with free action and therefore such lowering is usually slightly faster than lowering with a load.

LOAD BRAKE MAINTENANCE

The operation of the load brake provides automatic adjustment for wear of the brake disc. The only maintenance normally necessary is infrequent replacement of the ratchet and disc assembly. To check operation of the load brake, see instructions for daily, monthly and annual inspection in Preventive Maintenance Schedule (Section B).

FORM NO. 165-904-009

When Replacement Parts Are Needed, Order Only Yale® Factory Engineered Parts
EW/AW SERIES

GEAR TRAIN AND LOAD BRAKE ASSEMBLY

OPERATION DESCRIPTION AND MAINTENANCE OF YALE LOAD BRAKE

LOAD BRAKE REMOVAL

Follow steps 1, 2 and 8 of Disassembly Instructions in Section B (Maintenance).

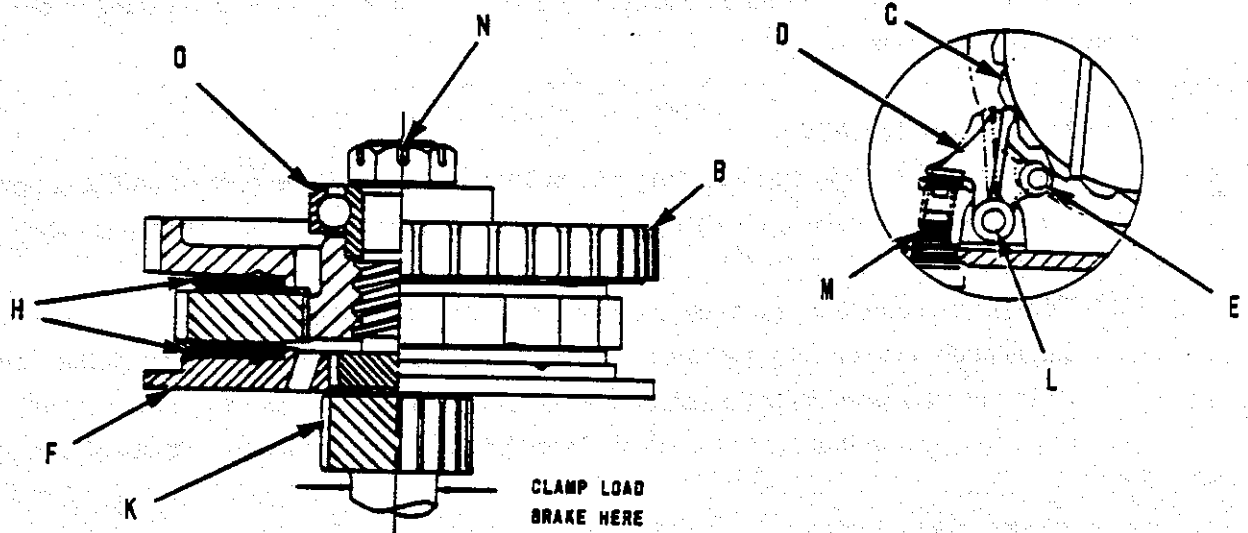

FIGURE 2

YA-0247

04-009
FORM NO. 165-904-009

When Replacement Parts Are Needed, Order Only Yale® Factory Engineered Parts

AUGUST 1984

EW/AW SERIES

SECTION 1340

GEARING & LOAD BRAKE

LOAD BRAKE DISASSEMBLY

Place the load brake in a vise and tighten jaws over the shoulder below the intermediate pinon K. Load brake is now ready for disassembly in the following manner.

1. Remove the cotter pin from the castellated nut and remove nut.
2. Remove high speed gear B.
3. Take off ratchet and disc assembly noting the direction the ratchet teeth are facing.

Before replacing the ratchet and disc assembly and the high speed gear, make sure all dirt or foreign material is cleaned off.

LOAD BRAKE RE - ASSEMBLY

1. Place the ratchet and disc assembly on the shaft, then thread the gear on until it is tight.
2. Place spacer and bearing on the end of the shaft and press it down into the ground recess in the gear.
3. Tighten the castellated nut down on the bearing. Then back the nut off slowly until the first castellation lines up with the hole drilled in the shaft and slip cotter pin through this hole. Open the brake and check the adjustment by turning the ratchet gear and disc assembly. If properly adjusted it should turn freely. Bend the cotter pin around nut and cut off excess.

LOAD BRAKE INSTALLATION

1. Insert the load brake in the gearcase cover.
2. Install pawl and pawl pin. (Note that the D chassis has a cotter pin which must be inserted through the pawl and pin.)
3. Take one button, then the spring, then the second button and slide them through the pawl in that order holding a finger over the bottom of the pawl so the buttons will not slide out. Press hard on buttons, compressing the spring enough to slide the complete pawl between ratchet disc and high speed gear.
4. Replace the pawl stop and/or spring assembly.

LUBRICATION

See Section B.

04-009

FORM NO. 165-904-009

When Replacement Parts Are Needed, Order Only Yale[®] Factory Engineered Parts

EW/AW SEREIS

Yale[®] Hoists

SECTION 1340

Gearing & Load
Brake

BEW & BAW

IMPORTANT
SELECT COMPONENT NUMBER AND PART
NUMBER FROM PARTS LIST IN FRONT OF
MANUAL FOR REPLACEMENT PARTS

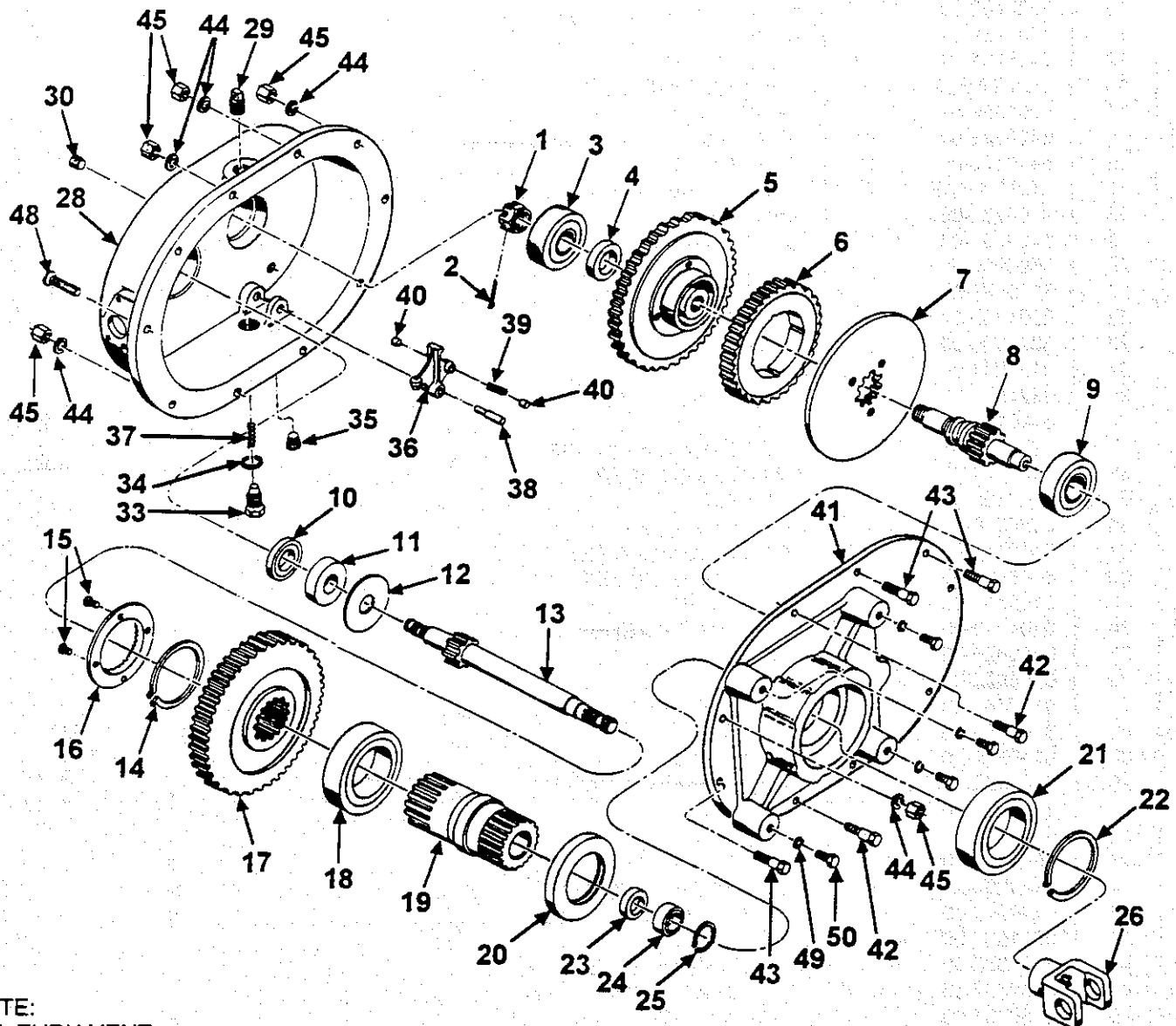

NOTE:
FILL THRU VENT
PLUG (ITEM 29)
TO OIL LEVEL
PLUG (ITEM 30)

When Replacement Parts Are Needed, Order Only Yale[®] Factory Engineered Parts
Rev. January, 1995
EW/AW Series

SECTION 1340

GEARING &
LOAD BRAKE

ITEM	PART NO.	DESCRIPTION	QTY.
1	0106673-00	SLOTTED NUT 3/4 - 16	1
2	0154203-00	COTTER PIN 5/32 x 1 3/4	1
3	5000259-01	BEARING	1
4	6411381-00	SPACER	1
4A	6445131-01	SPACER	1
5	SEE TABLE 1	HIGH SPEED GEAR	1
6	SEE TABLE 1	RATCHET WITH LINING	1
7	SEE TABLE 1	RATCHET DISC	1
8	SEE TABLE 1	SLOW SPEED PINION	1
9	0588167-00	BEARING	1
10	5024639-03	SEAL	1
11	5000259-01	BEARING	1
12	6418361-01	OIL SLINGER	1
13	SEE TABLE 1	DRIVING PINION	1
14	5001869-07	SNAP RING	1
15	6400329-07	POP RIVET	4
16	6410123-00	FACE GEAR	1
17	SEE TABLE 1	SLOW SPEED GEAR	1
18	0164933-00	BEARING	1
19	6438251-00	OUTPUT SHAFT	1
20	0596930-00	SEAL	1
21	5025079-02	BEARING	1
22	5001869-07	SNAP RING	1
23	5024639-06	SEAL	1
24	0151201-00	BEARING	1
25	0621590-00	SNAP RING	1
26	6436131-00	YOKE	1
27	7200959-01	SET SCREW 1/4 - 20 x 3/8	1
28	6434771-00	GEARCASE COVER	1
29	0107182-00	VENT PLUG	1
30	0230810-00	OIL LEVEL PLUG	1
31	6440411-00	INSPECTION COVER	1
32	6440401-00	INSPECTION COVER GASKET	1
33	0106849-00	PAWL STOP	1
34	0104013-00	PAWL STOP GASKET	1
35	0230825-00	DRAIN PLUG	1
36	0106822-00	PAWL	1
37	0110562-00	PAWL STOP SPRING	1
38	0106884-00	PAWL PIN	1
39	0110555-00	PAWL SPRING	1
40	0107993-00	PAWL SPRING RETAINER	2
41	6434021-00	GEARCASE	1
42	0116524-00	DOWEL BOLT	2
43	0570482-00	BOLT 3/8 - 16 x 1	7
44	0150264-00	LOCKWASHER 3/8 MED.	10
45	0149369-00	NUT 3/8 - 16	2
46	0621511-00	BOLT 1/4 - 20 x 1/2	4
47	0150308-00	LOCKWASHER 1/4 HEAVY	4
48	0109597-00	FLAT HEAD SCREW	1
49	0150266-00	LOCKWASHER	4
50	0596946-00	HEX. SCREW 1/2 - 13	4
*51	6451523-02	LIQUID GASKET (NOT SHOWN)	1

* LOCTITE GASKET NO.515 (50 ML BOTTLE)

FORM NO. 165-904-010

When Replacement Parts Are Needed, Order Only Yale® Factory Engineered Parts

EW / AW SERIES

2

REV. MAY, 1983

BEW — & BAW —

IMPORTANT
SELECT COMPONENT ASSEMBLY
NUMBER FROM PARTS LIST IN FRONT
COVER BEFORE SELECTING
REPLACEMENT ITEM NUMBER

6426022-01
 THRU
 6426022-13

TABLE 1

GEARING TABLE - "B" CHASSIS

Two Digit Code	Component Assembly Number	Gear Ratio	High Speed Gear (Item 5 & 5A)	Ratchet With Lining (Item 6)	Ratchet Disc (Item 7)	Intermediate Pinion (Item 8 & 8A)	Driving Pinion (Item 13)	Slow Speed Gear (Item 17)
Standard EW								
01	6426022-01	28.6	6418334-00 (88 teeth)	6415203-00	6440994-00	0104563-00 (12 teeth)	6438221-02 (20 teeth)	6437771-00 (78 teeth)
02	6426022-02	43.6	6418324-00 (94 teeth)	6415203-00	6440994-00	0104563-00 (12 teeth)	6438221-01 (14 teeth)	6437771-00 (78 teeth)
03	6426022-03	78.4	6418054-00 (98 teeth)	6415203-00	6415253-00	0585800-00 (10 teeth)	6438231-00 (10 teeth)	6437731-00 (80 teeth)
EW Without Load Brake *								
04	6426022-05	28.6	6445151-01 (88 teeth)	N/A	N/A	6445221-00 (12 teeth)	6438221-02 (20 teeth)	6437771-00 (78 teeth)
05	6426022-05	43.6	6445151-02 (94 teeth)	N/A	N/A	6445221-00 (12 teeth)	6438221-01 (14 teeth)	6437771-00 (78 teeth)
06	6426022-06	78.4	6445171-00 (98 teeth)	N/A	N/A	6445231-00 (10 teeth)	6438231-00 (10 teeth)	6437731-00 (80 teeth)
EW Explosion Proof								
07	6426022-07	28.6	6418334-00 (88 teeth)	6415203-00	6440994-00	0104563-00 (12 teeth)	6472311-03 (20 teeth)	6437771-00 (78 teeth)
08	6426022-08	43.6	6418324-00 (94 teeth)	6415203-00	6440994-00	0104563-00 (12 teeth)	6472311-02 (14 teeth)	6437771-00 (78 teeth)
09	6426022-09	78.4	6418054-00 (98 teeth)	6415203-00	6415253-00	0585800-00 (10 teeth)	6472311-01 (10 teeth)	6437731-00 (80 teeth)
Standard AW								
11	6426022-11	28.6	6418334-00 (88 teeth)	6415203-00	6440994-00	0104563-00 (12 teeth)	6450043-02 (20 teeth)	6437771-00 (78 teeth)
12	6426022-12	43.6	6418324-00 (94 teeth)	6415203-00	6440994-00	0104563-00 (12 teeth)	6450043-01 (14 teeth)	6437771-00 (78 teeth)
13	6426022-13	78.4	6418054-00 (98 teeth)	6415203-00	6415253-00	0585800-00 (10 teeth)	6450043-03 (10 teeth)	6437731-00 (80 teeth)

NOTE: Units W/O Load Brake Omit Items 1, 2, 4, 5, 6, 7, 36, 37, 38, 39 And 40. Use Items 4A, 5A And 8A in Place Of These Parts.

When Replacement Parts Are Needed, Order Only Yale® Factory Engineered Parts

SECTION 1340

**GEARING &
LOAD BRAKE**

RECOMMENDED SPARE PARTS LIST FOR ONE YEAR OPERATION

LOAD BRAKE KIT

ITEM NUMBER	COMPLETE KIT PART NUMBER	PART NO. 6460192-00	QTY. 1
6	RATCHET	6415203-00	1
36	PAWL	0106822-00	1
37	PAWL STOP SPRING	0110562-00	1
38	PAWL PIN	0106884-00	1
39	PAWL SPRING	0110555-00	1
40	PAWL SPRING RETAINER	0107993-00	2

GEARCASE SEAL PACKAGE

ITEM NUMBER	COMPLETE KIT PART NUMBER	PART NO. 6460142-00	QTY. 1
10	SEAL	5024639-03	1
20	SEAL	0596930-00	1
23	SEAL	5024639-06	1
32	INSPECTION COVER GASKET	6440401-00	1
34	PAWL STOP GASKET	0104013-00	1
51	LIQUID GASKET	6451523-02	1

Yale[®] Hoists

SECTION 1340

Gearing & Load
Brake

BEWX & BAWX

IMPORTANT
SELECT COMPONENT NUMBER AND PART
NUMBER FROM PARTS LIST IN FRONT OF
MANUAL FOR REPLACEMENT PARTS

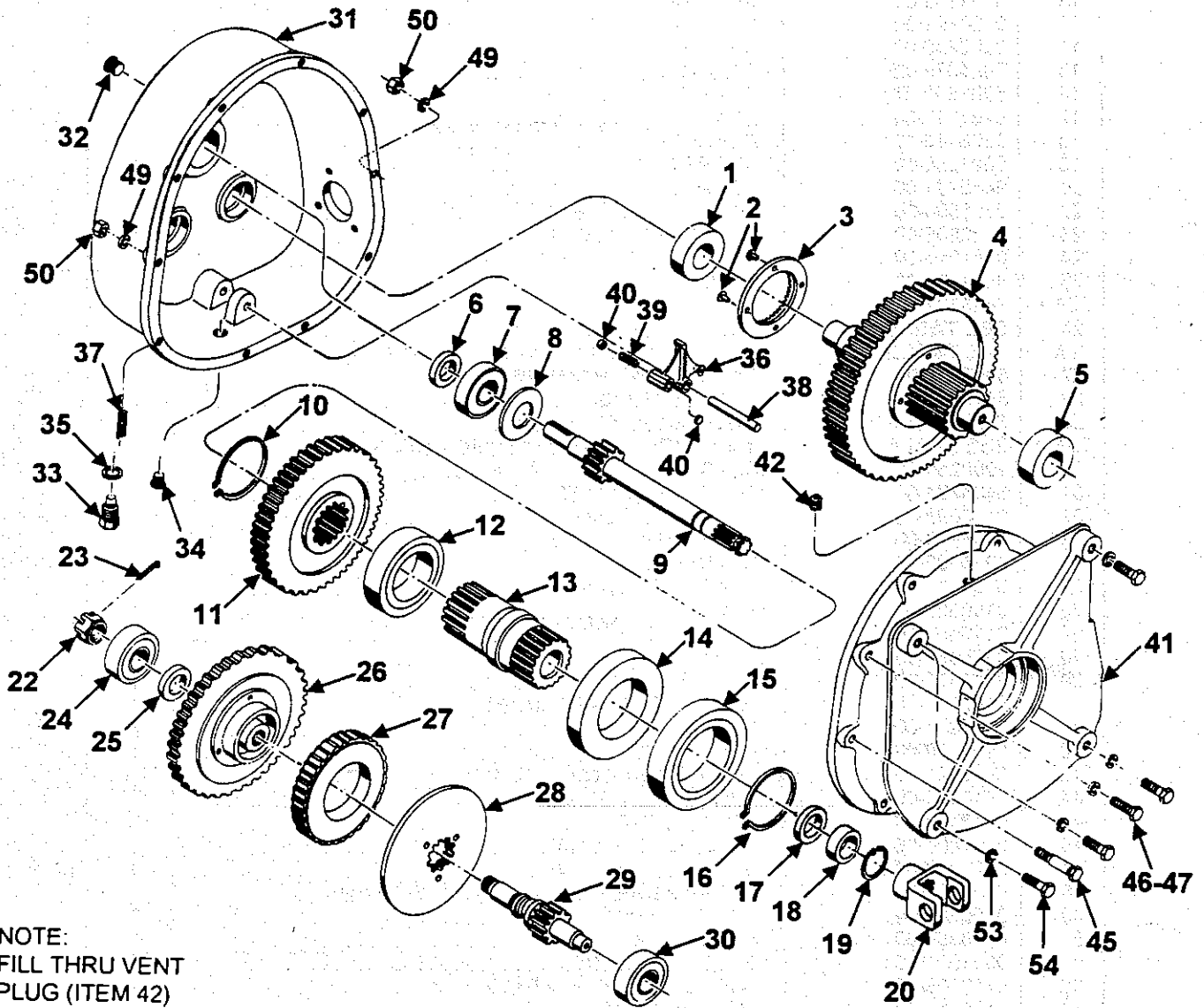

NOTE:
FILL THRU VENT
PLUG (ITEM 42)
TO OIL LEVEL
PLUG (ITEM 32)

When Replacement Parts Are Needed, Order Only Yale[®] Factory Engineered Parts
Rev. January, 1995 EW/AW Series

SECTION 1340

GEARING &
LOAD BRAKE

ITEM	PART NO.	DESCRIPTION	QTY.
1	5000259-01	BEARING	1
2	6400329-07	RIVET	4
3	6410123-00	FACE GEAR	1
4	SEE TABLE 1	INTERMEDIATE GEAR & PINION	1
5	0573891-00	BEARING	1
6	5024639-04	SEAL	1
7	0151258-00	BEARING	1
8	6434081-01	OIL SLINGER	1
9	SEE TABLE 1	DRIVING PINION	1
10	5001869-07	SNAP RING	1
11	6437741-00	SLOW SPEED GEAR	1
12	0164933-00	BEARING	1
13	6438851-00	OUTPUT SHAFT	1
14	0596930-00	SEAL	1
15	5025079-02	BEARING	1
16	5001869-07	SNAP RING	1
17	6401229-04	SEAL	1
18	0808186-00	BEARING	1
19	0621590-00	SNAP RING	1
20	6485721-00	YOKE	1
22	0106694-00	SLOTTED NUT 7/8 - 14	1
23	0102805-00	COTTER PIN 3/16 - 2	1
24	0151246-00	BEARING	1
25	6411391-00	SPACER	1
25A **	6445131-02	SPACER	1
26	SEE TABLE 1	HIGH SPEED GEAR	1
26A **	SEE TABLE 1	HIGH SPEED GEAR (W/O LOAD BRAKE)	1
27	6415273-00	RATCHET WITH LINING	1
28	6415293-00	RATCHET DISC	1
29	SEE TABLE 1	INTERMEDIATE PINION	1
29A **	SEE TABLE 1	INTERMEDIATE PINION (W/O LOAD BRAKE)	1
30	5000259-01	BEARING	1
31	6434781-00	GEARCASE COVER	1
32	0230825-00	OIL LEVEL PLUG	1
33	0106849-00	PAWL STOP	1
34	0230808-00	DRAIN PLUG	1
35	0104013-00	PAWL STOP GASKET	1
36	0106820-00	PAWL	1
37	0110562-00	PAWL STOP SPRING	1
38	0106884-00	PAWL PIN	1
39	0110567-00	PAWL SPRING	1
40	0107993-00	PAWL SPRING RETAINER	2
41	6434031-00	GEARCASE	1
42	0107182-00	VENT PLUG	1
43	6440421-00	INSPECTION COVER GASKET	1
44	6440431-00	INSPECTION COVER	1
45	0116523-00	DOWEL BOLT	2
46	0554868-00	BOLT 3/8 - 16 x 1 1/4	4
47	0623067-00	BOLT 5/16 - 18 x 1 1/4	4
48	0150262-00	LOCKWASHER 5/16 MED. (NOT SHOWN)	4
49	0150264-00	LOCKWASHER	6
50	0149369-00	NUT 3/8 - 16	2
51	0621511-00	BOLT 1/4 - 20 x 1/2	4
52	0150308-00	LOCKWASHER 1/4 HEAVY	4
53	0150266-00	LOCKWASHER	4
54	0596946-00	HEX. SCREW 1/2 - 13	4
*55	6451523-02	LIQUID GASKET (NOT SHOWN)	1

* LOCTITE GASKET ELIMINATOR NO. 515 (50 ML BOTTLE)

** NOT SHOWN

FORM NO. 165-904-011

When Replacement Parts Are Needed, Order Only Yale® Factory Engineered Parts

EW / AW SERIES

6

REV. JANUARY, 1983

BEW X & BAW X

IMPORTANT
SELECT COMPONENT ASSEMBLY
NUMBER FROM PARTS LIST IN FRONT
COVER BEFORE SELECTING
REPLACEMENT ITEM NUMBER

6426032-01
THRU
6426032-12

TABLE 1
GEARING TABLE - "B" CHASSIS

Two Digit Code	Component Assembly Number	Gear Ratio	High Speed Gear (26 & 26A)	Intermediate Gear & Pinion (Item 4)	Intermediate Pinion (29 & 29A)	Driving Pinion (Item 9)
Standard EW & Explosion Proof						
01	6426032-01	27.8	6418134-00 (67 teeth)	6437211-03 (56 teeth)	6437711-03 (28 teeth)	6438841-02 (18 teeth)
02	6426032-02	43.5	6448144-00 (70 teeth)	6437211-02 (60 teeth)	6437711-02 (24 teeth)	6438841-01 (15 teeth)
03	6426032-03	54.7	6418134-00 (67 teeth)	6437211-01 (67 teeth)	6437711-01 (17 teeth)	6438841-02 (18 teeth)
04	6426032-04	68.6	6418144-00 (70 teeth)	6437211-01 (67 teeth)	6437711-01 (17 teeth)	6483841-01 (15 teeth)
EW Without Load Brake						
05	6426032-05	27.8	6445181-02	6437211-03	6445211-02	6438841-02
06	6426032-06	43.5	6445181-01	6437211-02	6445211-01	6438841-01
07	6426032-07	54.7	6445181-02	6437211-01	6445241-00	6438841-02
08	6426032-08	68.6	6445181-01	6437211-01	6445241-00	6438841-01
Standard AW						
09	6426032-09	27.8	6418134-00	6437211-03 (56 teeth)	6437711-03	6483801-02
10	6426032-10	43.5	6418144-00	6437211-02 (60 teeth)	6437711-02	6483801-01
11	6426032-11	54.7	6418134-00	6437211-01 (67 teeth)	6437711-01	6483801-02
12	6426032-12	68.6	6418144-00	6437211-01 (67 teeth)	6437711-01	6483801-01

NOTE: Units W/O Load Brake Omit Items 36, 37, 38, 39, 40, 22, 23, 25, 26, 27, 28, 29. Use Items 29A, 26A, 25A.

When Replacement Parts Are Needed, Order Only Yale® Factory Engineered Parts

SECTION 1340

GEARING &
LOAD BRAKE

RECOMMENDED SPARE PARTS LIST FOR ONE YEAR OPERATION

LOAD BRAKE KIT

ITEM NUMBER	COMPLETE KIT PART NUMBER	PART NO. 6460202-00	QTY. 1
27	RATCHET	6415273-00	1
36	PAWL	0106820-00	1
37	PAWL STOP SPRING	0110562-00	1
38	PAWL PIN	0106884-00	1
39	PAWL SPRING	0110567-00	1
40	PAWL SPRING RETAINER	0107993-00	2

GEARCASE SEAL PACKAGE

ITEM NUMBER	COMPLETE KIT PART NUMBER	PART NO. 6460152-00	QTY. 1
6	SEAL	5024639-04	1
14	SEAL	0596930-00	1
17	SEAL	6401229-04	1
35	PAWL STOP GASKET	0104013-00	1
43	INSPECTION COVER GASKET	6440421-00	1
55	LIQUID GASKET	6451523-02	1

Yale Hoisting Equipment

SECTION 1351

AW SERIES AIR MOTOR BRAKE ASSEMBLY

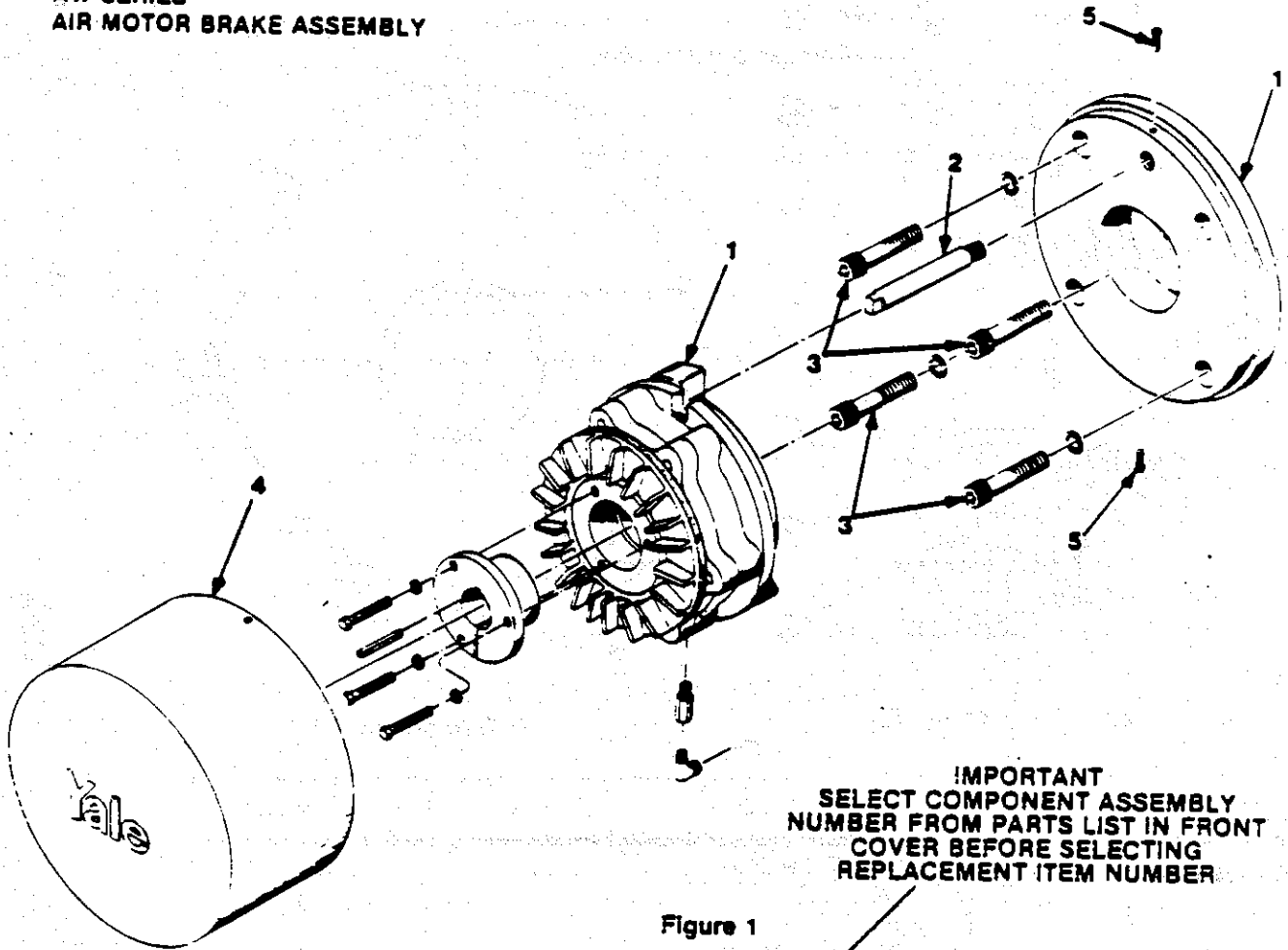

Figure 1

ITEM NBR.	Component & PART NBR.			DESCRIPTION
1	6450073-01	6486311-01	6450333-01	MOTOR BRAKE ASSEMBLY
2	6450023-00	6450313-00	6483831-00	STUD
*	6461063-01	6461063-02	6461063-03	BRAKE DISC KIT
*	6461063-11	6461063-12	6461063-13	REPAIR KIT
3	0579224-00	0579224-00	0579224-00	SCREW
4	6487541-00	6487541-00	6487541-00	COVER
5	0148633-00	0148633-00	0148633-00	SCREW

* See Page 2 for more detailed information.

FORM NO. 165-907-015

When Replacement Parts Are Needed, Order Only Yale[®] Factory Engineered Parts

OCTOBER, 1984

SECTION 1351

AW SERIES
AIR MOTOR BRAKE ASSEMBLY

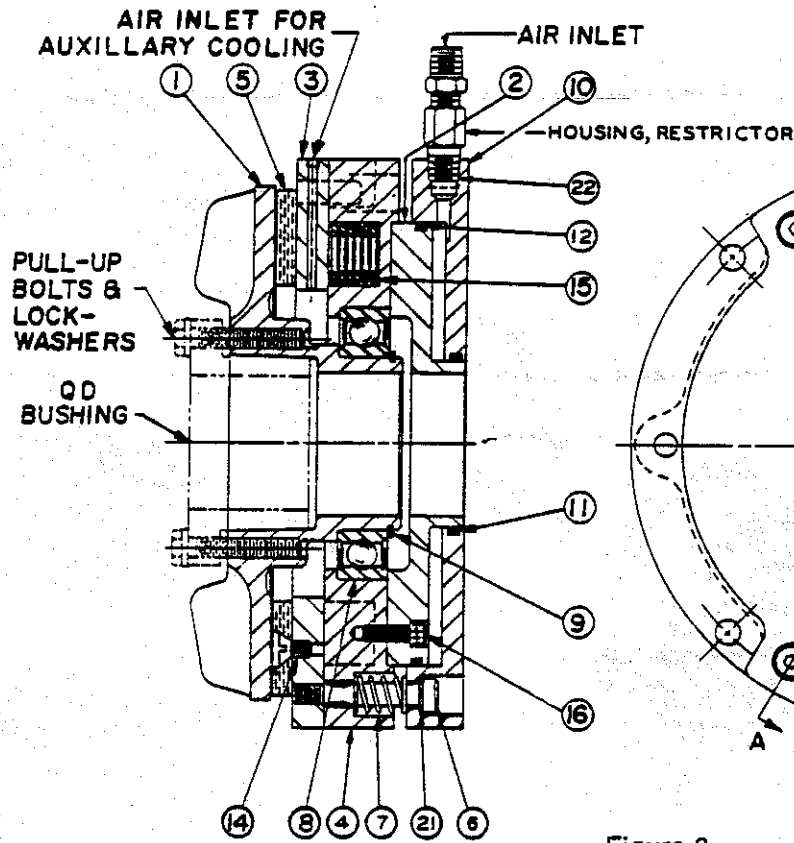

Figure 2

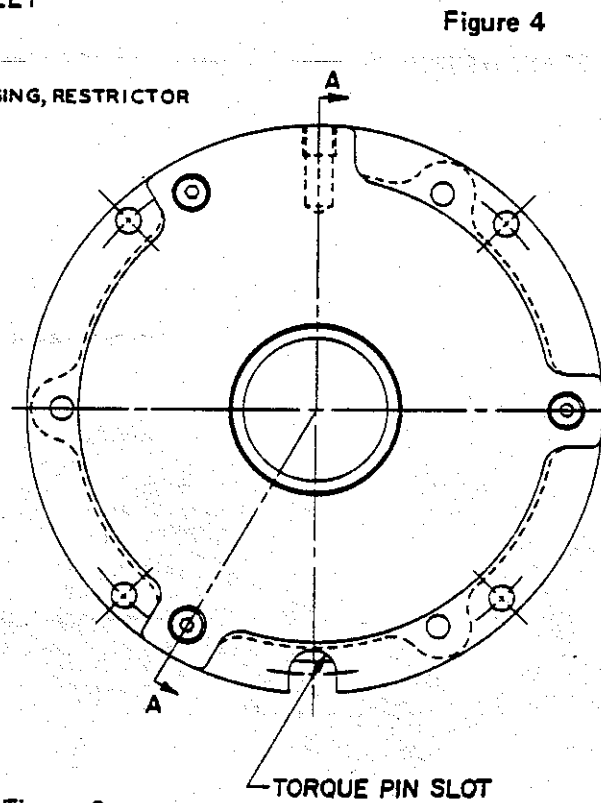

Figure 4

ITEM	REPAIR KIT	BRAKE DISC KIT	DESCRIPTION	QTY.
1			HUB/FRICTION DISC	1
2			PISTON	1
3			PLATE	1
4			HOUSING PIN ASSY.	1
5	*	*	FACING, FRICTION	2
6	*		SCREW, SHOULDER	3
7			SPRING, RETURN	3
8	*		BEARING	1
9			RING, RETAINING	1
10			CYLINDER	1
11	*		O-RING	1
12	*		O-RING	1
14	*	*	SCREW, MACHINE	6
15			SPRING, ENGAGING	6
16			SCREW, CAP	5
19			HOSE ASSY. (not shown)	1
21			WASHER, BRASS	3
22			RESTICTOR	1

07-015

FORM NO. 185-907-015

When Replacement Parts Are Needed, Order Only Yale® Factory Engineered Parts

Brake Removal

Disconnect air supply line to the hoist before attempting service or repair.

1. Disconnect air line to brake. Remove cover screws and cover.
2. Remove three hex. head bolts from taper lock bushing at the end of brake. Re-insert bolts in the threaded holes in the bushing flange and tighten them. Remove the bushing and the brake from the shaft.

Brake Installation (See Figure 2)

1. Before mounting the brake make sure there is adequate clearance for the cylinder (Item 10) to move freely. The brake will not release properly and damage to the "O" rings (Items 11 and 12) could result if the cylinder travel is restricted.
2. Use a clean, dry cloth to remove dirt or foreign particles from the taper on the QD bushing and the hub/friction disc (Item 1).
3. Position the brake hub on the shaft and assemble the key.
4. Slide the brake into position over the brake hub, aligning the untapped holes in the bushing's flange with the tapped holes in the hub/friction disc and assemble the pull - up bolts and lockwashers.
5. Tighten the pull - up bolts in the brake hub alternately and evenly (tightening torque - 10 ft. -lbs.). Runout will be minimized if a dial indicator is used as the pull -up bolts are tightened. Use the perpendicular surface of the plate (Item 3) as a reference. After tightening, there must be a gap between the hub/friction disc and the brake hub to insure a satisfactory fit.
6. Secure the brake's spring housing (Item 4) to prevent rotation and take up the braking torque. A torque pin slot is provided in the spring housing's flange.

Cut off air supply to the hoist by disconnecting the air supply line and lowering the load before attempting service or repair.

Manual Release

To manually release the brake, disconnect air supply line at the bottom of the brake and connect direct line air to the elbow connector. This will keep the brake open until air pressure is removed.

Brake Service

1. **Torque Adjustment** - The Fail Safe Air Brake has been selected for the torque required to stop the load. Additional torque or a lower torque can be obtained by the addition or removal of springs in the brake.
2. **Replacement of Friction Discs** - When wear of rotating friction discs reaches 1/8 in., replace as follows:

Remove cover. Apply disengagement air pressure to brake. Rotate hub/friction disc until holes in disc align with friction facing mounting screws. Remove six (6) mounting screws.

Friction facing can then be removed from the sides in two halves.

Trouble Shooting

1. Brake does not release:
 - (a) Check brake and air supply line visually for damage resulting in air leaks.
 - (b) Check air supply pressure into hoist.
 - (c) Check air pressure in air brake line.
 - (d) If brake is receiving proper air pressure the brake cylinder or "O" rings may be damaged.
2. Brake does not stop load:
 - (a) Check brake visually for broken or damaged parts.
 - (b) Check disc for wear and glazing.
 - (c) Make certain that taper lock bushing bolts are intact and tightened.

Yale Hoisting Equipment

AW SERIES
STANDARD HEADROOM

SECTION 1410
LIMIT VALVE

UPPER LIMIT VALVE

**IMPORTANT
SELECT COMPONENT ASSEMBLY
NUMBER FROM PARTS LIST IN FRONT
COVER BEFORE SELECTING
REPLACEMENT ITEM NUMBER**

Component
Number
6459672-00

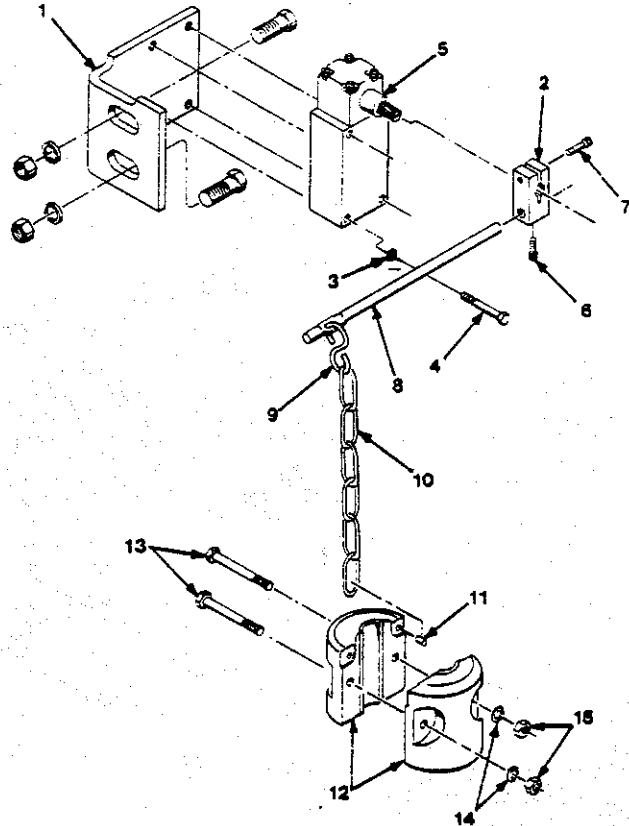

ITEM	PART NO.	DESCRIPTION	QTY.
2	6491211-00	HUB	1
3	0150285-00	LOCKWASHER NO. 10	2
4	0148768-00	R.H. SCREW 10 - 32	2
5	6486251-01	LIMIT VALVE	1
6	0656254-00	SOCKET SCREW 10 - 32 x 3/8	1
7	0656255-00	SOCKET SCREW 10 - 32 x 5/8	1
8	6483211-00	L.S. ROD	1
9	0591497-00	S - HOOK	1
10	6450221-79	CONTROL CHAIN	*
11	0105760-00	L.S. WEIGHT PIN	2
12	6495351-00	L.S.WEIGHT	2
13	0109484-00	R.H. SCREW 1/4 - 20 x 1 3/4	2
14	0150308-00	LOCKWASHER 1/4 in.	2
15	0149707-00	JAM NUT 1/4 - 20	2
16	0554850-00	SCREW 1/2 - 13 x 1 1/4	2
17	0150266-00	LOCKWASHER 1/2 in.	2
18	0149708-00	NUT 1/2	2
19	5041178-81	TUBING 1/4 OD (NOT SHOWN)	*

*SPECIFY LENGTH

FORM NO. 165-908-042

When Replacement Parts Are Needed, Order Only Yale® Factory Engineered Parts

MAY 1984

AW SERIES

SECTION 1410
LIMIT VALVE
AW SERIES
CLOSE HEADROOM

IMPORTANT
SELECT COMPONENT ASSEMBLY
NUMBER FROM PARTS LIST IN FRONT
COVER BEFORE SELECTING
REPLACEMENT ITEM NUMBER

UPPER LIMIT VALVE

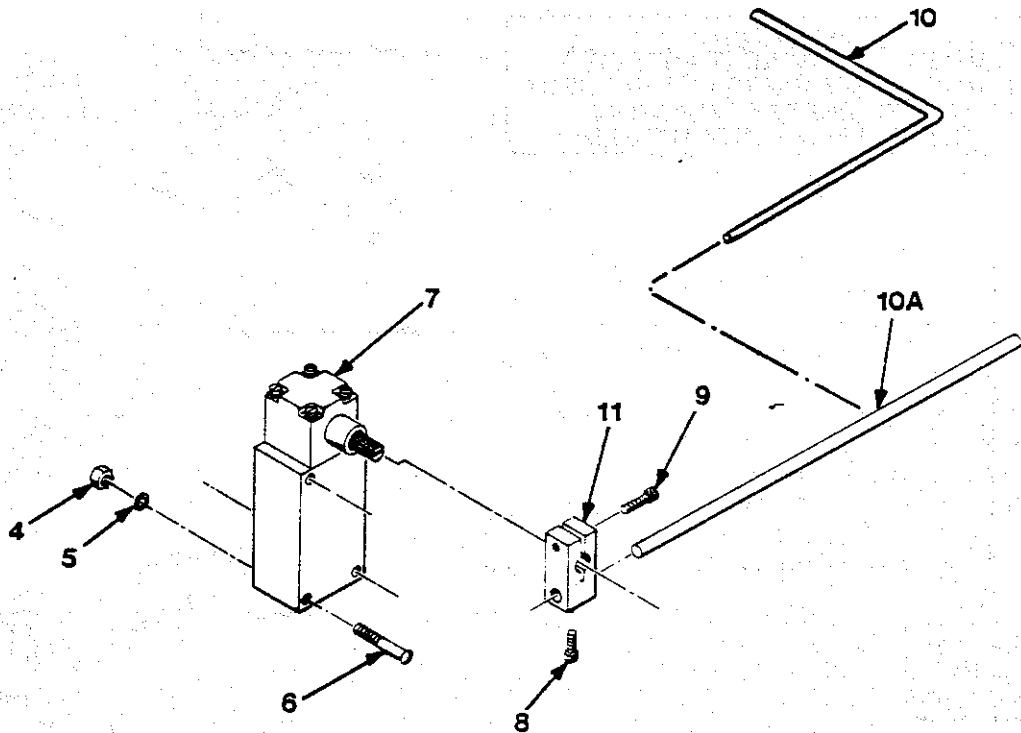

TABLE 2

Component Number	Item No. 7 Valve Part Number
6459682-00	6486251-02
6459692-00	6486251-02

ITEM	PART NO.	DESCRIPTION	QTY.
4	0149393-00	NUT 10-32	2
5	0150285-00	LOCKWASHER NO. 10	2
6	0148641-00	MACHINE SCREW	2
7	SEE TABLE 2	LIMIT SWITCH	1
8	0656254-00	SCREW 10-32 x 3/8	1
9	0656255-00	SCREW 10-32 x 5/8	1
10	6477621-00	ROD, LIMIT SWITCH 90° BEND	1
10A	6467771-00	ROD, LIMIT SWITCH	1
11	6491211-00	HUB	1
12	5041178-81	TUBING 1/4 OD (NOT SHOWN)	*

FORM NO. 165-908-042

When Replacement Parts Are Needed, Order Only Yale® Factory Engineered Parts

MAY 1984

AW SERIES

Yale Hoisting Equipment

AW SERIES ALL CHASSIS AIR POWERED HOIST
TRAVELING NUT GEARED LIMIT VALVE ASSEMBLY

SECTION 1420/30

LIMIT VALVE

IMPORTANT
SELECT COMPONENT ASSEMBLY
NUMBER FROM PARTS LIST IN FRONT
COVER BEFORE SELECTING
REPLACEMENT ITEM NUMBER

ITEM 20	ITEM 21	ITEM 33	ITEM 34	LIMIT VALVE ASSEMBLY
641295100	641292100	645225105	011631100	645467301
641295100	641292100	645225106	011631200	645467302
641295100	641292100	645225107	011631300	645467303
641295100	641292100	645225108	011631400	645467304
641294100	641293100	645225105	011631100	645467317
641294100	641293100	645225106	011631200	645467318
641294100	641293100	645225107	011631300	645467319
641294100	641293100	645225108	011631400	645467320

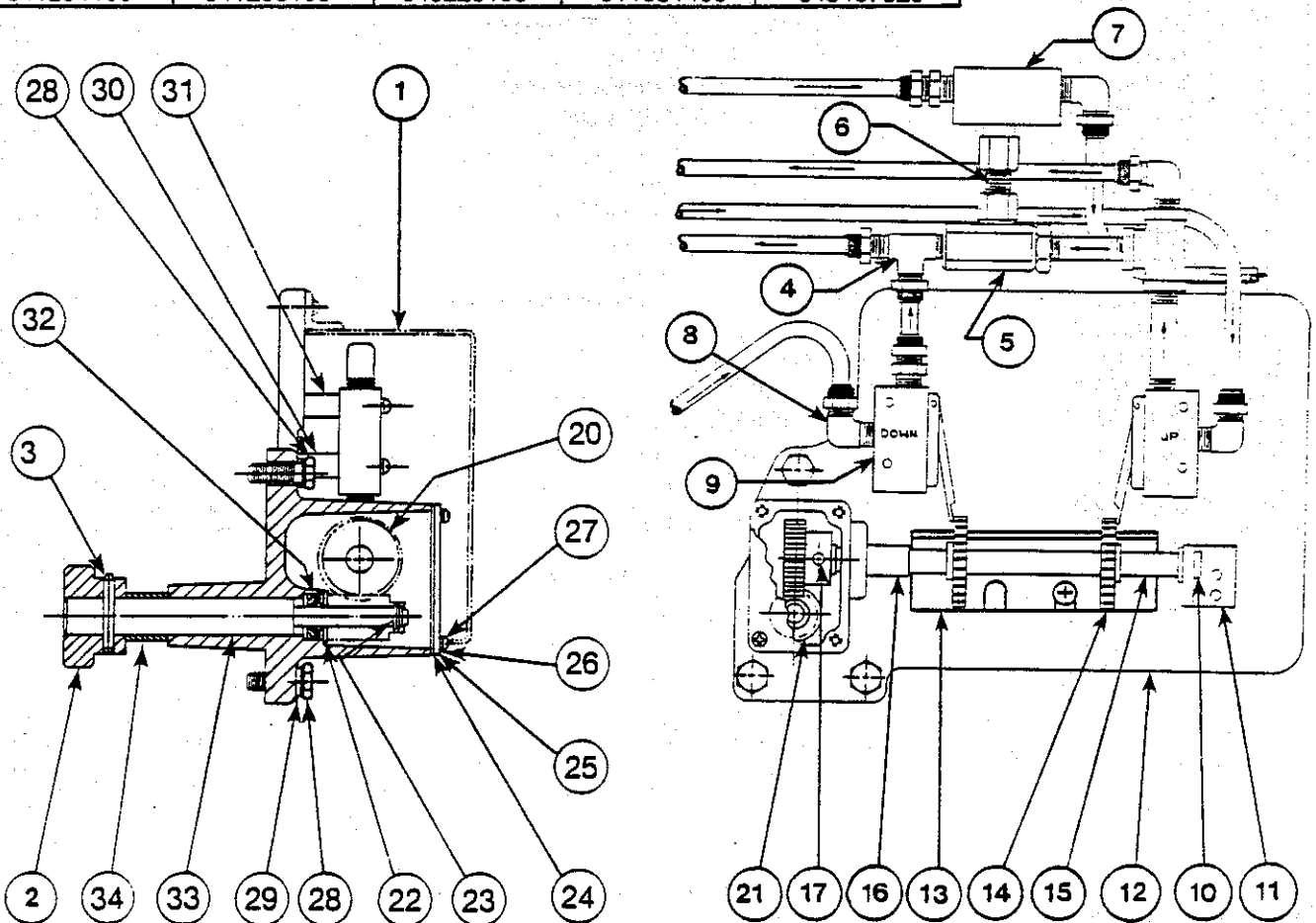

Adjustment

YD - 0574

To adjust the limit valves or to set them at other desired levels remove the limit valve cover. Run the unit down noticing the valve toward which the nut travels. Stop the bottom block at the desired lower limit. Remove the flat bar under the traveling nuts. Move the nut nearest the valve until the valve can be heard to trip. Replace the flat bar under the traveling nuts. Repeat the above to set the upper limit valve.

FORM NO. 165-908-043

When Replacement Parts Are Needed, Order Only Yale® Factory Engineered Parts

**LIMIT VALVE PARTS
TRAVELING NUT LIMIT VALVE ASSEMBLY**

ITEM	PART NO.	DESCRIPTION	QTY.
1	6449903-00	LIMIT SWITCH COVER	1
2	6412881-00	PINION	1
3	0230207-00	ROLL PIN	1
4	6449993-03	MALE TEE	1
5	5019228-00	PRESSURE SELECTOR	1
6	0157509-00	1/8 NIPPLE (3/4 LG.)	1
7	6497001-00	PILOT VALVE	2
8	5041148-00	ELLS (WITH 0184797-00 ELBOW)	4
9	6410008-00	3 WAY VALVE	2
10	6412871-00	BUSHING	2
11	6454531-00	BRACKET	1
12	6454541-00	GEARCASE	1
13	6449101-00	TRAVEL CAM RETAINER	1
14	6440883-00	TRAVEL CAM (24 THREADS/INCH)	2
15	6412891-00	SHAFT (24 THREADS/INCH)	1
16	6454611-01	SPACER	1
17	0109562-00	SET SCREW	1
22	0114291-00	WASHER	1
23	0318061-00	ROLL PIN	1
24	6459091-00	GASKET	1
25	6450551-00	COVER	1
26	0150357-00	LOCKWASHER	4
27	0109468-00	MACHINE SCREW	4
28	0622328-00	5/16 - 18 BOLT	3
29	0150262-00	LOCKWASHER	3
30	6454611-02	SPACER (LONG)	2
31	6454621-01	SPACER (SHORT)	2
32	6453718-00	SEAL	1

When Replacement Parts Are Needed, Order Only Yale® Factory Engineered Parts

IMPORTANT
SELECT COMPONENT ASSEMBLY
NUMBER FROM PARTS LIST IN FRONT
COVER BEFORE SELECTING
REPLACEMENT ITEM NUMBER

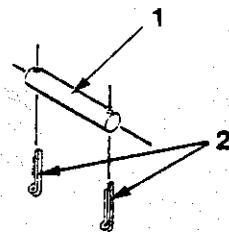

S2

FIGURE 1

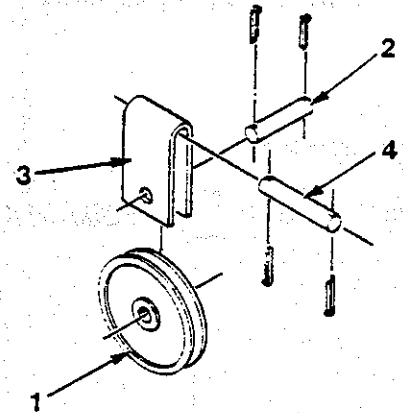

D2

FIGURE 2

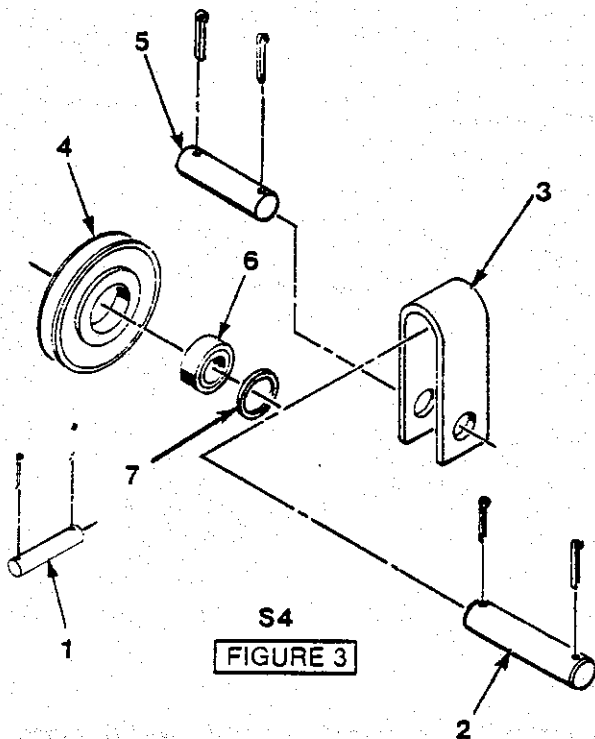

S4

FIGURE 3

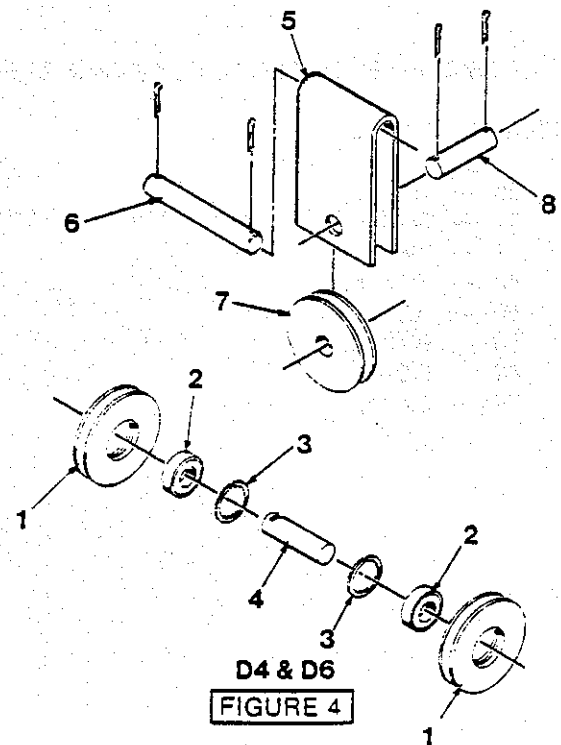

D4 & D6

FIGURE 4

03-110-5
FORM NO. 165-903-110

When Replacement Parts Are Needed, Order Only Yale® Factory Engineered Parts

DETERMINE WIRE ROPE DIAMETER

SEE PARTS LIST IN FRONT COVER FOR WIRE ROPE ASM NUMBER

EXAMPLE

TYPICAL ROPE DESCRIPTION

DESCRIPTION	COMPONENT	SEC.
ROPE ASM 31 S060-S6X19-053	644728201	1610

ROPE DIAMETER
31 — 5/16 in. NOMINAL

NOTE: 31 DESIGNATES NOMINAL ROPE DIAMETER.

SIZES AVAILABLE

- 25 — 1/4 in.
- 31 — 5/16 in.
- 37 — 3/8 in.
- 43 — 7/16 in.
- 50 — 1/2 in.
- 56 — 9/16 in.
- 62 — 5/8 in.
- 75 — 3/4 in.

When Replacement Parts Are Needed, Order Only Yale® Factory Engineered Parts

Yale Hoisting Equipment

SECTION 1630

REEVING KIT

1. SELECT CHASSIS & REEVING
2. DETERMINE WIRE ROPE DIAMETER (SEE SECTION B)
3. USE TABLES TO SELECT REPLACEMENT PARTS

S2 - REEVING TABLE

Chassis	Reev-ing	Rope Dia.	Item No.	Part Number	Description	Fig. No.
B & C	S2	1/4	1	6444951-07	Rope Anchor Pin	1
B, C & D	S2	5/16, 7/16, & 1/2		6444951-08	Rope Anchor Pin	1
D	S2	5/8		6487921-01	Rope Anchor Pin	1
E	S2	7/16, 1/2 & 5/8		6487921-01	Rope Anchor Pin	1
F	S2	3/4		6487921-01	Rope Anchor Pin	1
	S2	1/2		6444951-02	Rope Anchor Pin	1
	S2	5/8		6487921-05	Rope Anchor Pin	1
	S2	3/4		6487921-06	Rope Anchor Pin	1
B & C	S2	1/4	2	0381401-00	Cotter Pin	1
B, C & D	S2	5/16, 7/16, & 1/2		0381401-00	Cotter Pin	1
D	S2	5/8		0154255-00	Cotter Pin	1
E	S2	7/16, 1/2, & 5/8		0154255-00	Cotter Pin	1
F	S2	3/4		0381403-00	Cotter Pin	1
	S2	1/2		0154255-00	Cotter Pin	1
	S2	5/8		0154236-00	Cotter Pin	1
	S2	3/4		0154270-00	Cotter Pin	1

D2 - REEVING TABLE

Chassis	Reev-ing	Rope Dia.	Item No.	Part Number	Description	Fig. No.
B	D2	1/4 & 5/16	1	6479081-00	Equalizer Sheave	2
C & D		1/4, 5/16 & 3/8		6479081-00	Equalizer Sheave	2
D		7/16		6479071-00	Equalizer Sheave	2
E		3/8 & 7/16		6479071-00	Equalizer Sheave	2
F		1/2		6457761-00	Equalizer Sheave	2
		7/16 & 1/2		6457761-00	Equalizer Sheave	2
B	D2	1/4 & 5/16	2	6454071-00	Equalizer Sheave Pin	2
C & D		1/4, 5/16 & 3/8		6454071-00	Equalizer Sheave Pin	2
D		7/16		6452031-05	Equalizer Sheave Pin	2
E		3/8 & 7/16		6452031-05	Equalizer Sheave Pin	2
F		1/2		6452031-07	Equalizer Sheave Pin	2
		7/16 & 1/2		6452031-07	Equalizer Sheave Pin	2
B	D2	1/4 & 5/16	3	6452041-06	Yoke	2
C & D		1/4, 5/16 & 3/8		6452041-06	Yoke	2
D		7/16		6452041-09	Yoke	2
E		3/8 & 7/16		6452041-09	Yoke	2
F		1/2		6452041-12	Yoke	2
		7/16 & 1/2		6452041-12	Yoke	2
B	D2	1/4 & 5/16	4	6480741-00	Yoke Shaft	2
C & D		1/4, 5/16 & 3/8		6480741-00	Yoke Shaft	2
D		7/16		6480731-00	Yoke Shaft	2
E		3/8 & 7/16		6480731-00	Yoke Shaft	2
F		1/2		6480721-00	Yoke Shaft	2
		7/16 & 1/2		6480721-00	Yoke Shaft	2

03-110-3
FORM NO. 165-903-110

When Replacement Parts Are Needed, Order Only Yale® Factory Engineered Parts

OCTOBER 1984

EW/AW SERIES

SECTION 1630

REEVING KIT

S4 - REEVING TABLE

Chassis	Reev- ing	Rope Dia.	Item No.	Part Number	Description	Fig. No.
B B C C D D E E F F	S4	5/16	1	6444951-08	Rope Anchor Pin	3
	S4	3/8		6444951-08	Rope Anchor Pin	3
	S4	3/8		6444951-08	Rope Anchor Pin	3
	S4	7/16 & 1/2		6444951-08	Rope Anchor Pin	3
	S4	5/8		6487921-01	Rope Anchor Pin	3
	S4	1/2		6444951-08	Rope Anchor Pin	3
	S4	3/4		6487921-02	Rope Anchor Pin	3
	S4	5/8		6443364-00	Rope Anchor Pin	3
	S4	3/4		6443364-00	Rope Anchor Pin	3
B B C C D D E E F F	S4	5/16	2	6443991-09	Yoke Shaft	3
	S4	3/8		6486121-01	Yoke Shaft	3
	S4	3/8		6443991-09	Yoke Shaft	3
	S4	7/16 & 1/2		6486121-01	Yoke Shaft	3
	S4	5/8		6444001-12	Yoke Shaft	3
	S4	1/2		6488121-01	Yoke Shaft	3
	S4	3/4		6444001-13	Yoke Shaft	3
	S4	5/8		6487921-03	Yoke Shaft	3
	S4	3/4		6487921-04	Yoke Shaft	3
B B C C D D E E F F	S4	5/16	3	6482841-01	Yoke	3
	S4	3/8		6482841-02	Yoke	3
	S4	3/8		6482841-01	Yoke	3
	S4	7/16 & 1/2		6482841-02	Yoke	3
	S4	5/8		6482841-03	Yoke	3
	S4	1/2		6482841-02	Yoke	3
	S4	3/4		6482841-04	Yoke	3
	S4	5/8		6443354-00	Yoke	3
	S4	3/4		6443354-00	Yoke	3
B B C C D D E E F F	S4	5/16	4	0109885-00	Idler Sheave	3
	S4	3/8		0109996-00	Idler Sheave	3
	S4	3/8		0109885-00	Idler Sheave	3
	S4	7/16 & 1/2		0109996-00	Idler Sheave	3
	S4	5/8		0109946-00	Idler Sheave	3
	S4	1/2		0109996-00	Idler Sheave	3
	S4	3/4		6466171-00	Idler Sheave	3
	S4	5/8		6425776-00	Idler Sheave	3
	S4	3/4		6424066-00	Idler Sheave	3
B B C C D D E E F F	S4	5/16	5	6452031-16	Idler Sheave Shaft	3
	S4	3/8		6452031-09	Idler Sheave Shaft	3
	S4	3/8		8452031-16	Idler Sheave Shaft	3
	S4	7/16 & 1/2		6452031-09	Idler Sheave Shaft	3
	S4	5/8		6452031-12	Idler Sheave Shaft	3
	S4	1/2		6452031-09	Idler Sheave Shaft	3
	S4	3/4		6452031-15	Idler Sheave Shaft	3
	S4	5/8		6444103-00	Idler Sheave Shaft	3
	S4	3/4		6444103-00	Idler Sheave Shaft	3
B B C C D D E E F F	S4	5/16	6	0151281-00	Idler Sheave Bearing	3
	S4	3/8		6456668-00	Idler Sheave Bearing	3
	S4	3/8		0151281-00	Idler Sheave Bearing	3
	S4	7/16 & 1/2		6456668-00	Idler Sheave Bearing	3
	S4	5/8		0100846-00	Idler Sheave Bearing	3
	S4	1/2		6456668-00	Idler Sheave Bearing	3
	S4	3/4		6441528-00	Idler Sheave Bearing	3
	S4	5/8		6441528-00	Idler Sheave Bearing	3
	S4	3/4		6441528-00	Idler Sheave Bearing	3
B B C C D D E E F F	S4	5/16	7	5003439-14	Bearing Retainer	3
	S4	3/8		5003439-02	Bearing Retainer	3
	S4	3/8		5003439-14	Bearing Retainer	3
	S4	7/16 & 1/2		5003439-02	Bearing Retainer	3
	S4	5/8		5003439-11	Bearing Retainer	3
	S4	1/2		5003439-02	Bearing Retainer	3
	S4	3/4		6401619-02	Bearing Retainer	3
	S4	5/8		6401619-02	Bearing Retainer	3
	S4	3/4		6401619-02	Bearing Retainer	3

FORM NO. 165-903-110

When Replacement Parts Are Needed, Order Only Yale® Factory Engineered Parts

D4 - REEVING TABLE

Chassis	Reeving	Rope Dia.	Item No.	Part Number	Description	Fig. No.
B & C C & D D E E F F	D4	1/4	1	0109892-00	Idler Sheave	4
	D4	5/16 & 3/8		0616652-00	Idler Sheave	4
	D4	7/16		0109996-00	Idler Sheave	4
	D4	3/8 & 7/16		0109996-00	Idler Sheave	4
	D4	1/2 & 9/16		6455711-00	Idler Sheave	4
	D4	7/16 & 1/2		6487561-00	Idler Sheave	4
B & C C & D D E E F F	D4	1/4	2	0151283-00	Sheave Bearing	4
	D4	5/16 & 3/8		0100822-00	Sheave Bearing	4
	D4	7/16		0274205-00	Sheave Bearing	4
	D4	3/8 & 7/16		0274205-00	Sheave Bearing	4
	D4	1/2 & 9/16		6401629-01	Sheave Bearing	4
	D4	7/16 & 1/2		6401629-01	Sheave Bearing	4
B & C C & D D E E F F	D4	1/4	3	5003439-12	Bearing Retainer	4
	D4	5/16 & 3/8		5003439-15	Bearing Retainer	4
	D4	7/16		5003439-02	Bearing Retainer	4
	D4	3/8 & 7/16		5003439-02	Bearing Retainer	4
	D4	1/2 & 9/16		6401619-01	Bearing Retainer	4
	D4	7/16 & 1/2		6401619-01	Bearing Retainer	4
B & C C & D D E E F F	D4	1/4	4	6475991-00	Idler Sheave Shaft	4
	D4	5/16 & 3/8		6472811-00	Idler Sheave Shaft	4
	D4	7/16		6469581-00	Idler Sheave Shaft	4
	D4	3/8 & 7/16		6469581-00	Idler Sheave Shaft	4
	D4	1/2 & 9/16		6473961-00	Idler Sheave Shaft	4
	D4	7/16 & 1/2		6473961-00	Idler Sheave Shaft	4
B & C C & D D E E F F	D4	1/4	5	6452041-06	Yoke	4
	D4	5/16 & 3/8		6452041-08	Yoke	4
	D4	7/16		6452041-09	Yoke	4
	D4	3/8 & 7/16		6452041-09	Yoke	4
	D4	1/2 & 9/16		6452041-12	Yoke	4
	D4	7/16 & 1/2		6452041-12	Yoke	4
B & C C & D D E E F F	D4	1/4	6	6480741-00	Yoke Shaft	4
	D4	5/16 & 3/8		6480751-00	Yoke Shaft	4
	D4	7/16		6480731-00	Yoke Shaft	4
	D4	3/8 & 7/16		6480731-00	Yoke Shaft	4
	D4	1/2 & 9/16		6480721-00	Yoke Shaft	4
	D4	7/16 & 1/2		6480721-00	Yoke Shaft	4
B & C C & D D E E F F	D4	1/4	7	6479081-00	Equalizer Sheave	4
	D4	5/16 & 3/8		6457771-00	Equalizer Sheave	4
	D4	7/16		6479071-00	Equalizer Sheave	4
	D4	3/8 & 7/16		6479071-00	Equalizer Sheave	4
	D4	1/2 & 9/16		6457761-00	Equalizer Sheave	4
	D4	7/16 & 1/2		6457761-00	Equalizer Sheave	4
B & C C & D D E E F F	D4	1/4	8	6454071-00	Equalizer Sheave Pin	4
	D4	5/16 & 3/8		6454071-00	Equalizer Sheave Pin	4
	D4	7/16		6452031-05	Equalizer Sheave Pin	4
	D4	3/8 & 7/16		6452031-05	Equalizer Sheave Pin	4
	D4	1/2 & 9/16		6452031-07	Equalizer Sheave Pin	4
	D4	7/16 & 1/2		6452031-07	Equalizer Sheave Pin	4

When Replacement Parts Are Needed, Order Only Yale® Factory Engineered Parts

**SECTION 1630
REEVING KIT**

D6 - REEVING TABLE

Chassis	Reev- ing	Rope Dia.	Item No.	Part Number	Description	Fig. No.
T T M	D6	7/16 - 1/2	1	6455711-00	Idler Sheave	4
	D6	1/2		6487561-00	Idler Sheave	4
	D6	9/16		6423126-00	Idler Sheave	4
T T M	D6	7/16 & 1/2	2	6401629-01	Sheave Bearing	4
	D6	1/2		6401629-01	Sheave Bearing	4
	D6	9/16		6401629-01	Sheave Bearing	4
T T M	D6	7/16 & 1/2	3	6401619-01	Bearing Retainer	4
	D6	1/2		6401619-01	Bearing Retainer	4
	D6	9/16		6401619-01	Bearing Retainer	4
T T M	D6	7/16 & 1/2	4	6473941-00	Idler Sheave Shaft	4
	D6	1/2		6473941-00	Idler Sheave Shaft	4
	D6	9/16		6473941-00	Idler Sheave Shaft	4
T T M	D6	7/16 & 1/2	5	6452021-02	Yoke	4
	D6	1/2		6452021-02	Yoke	4
	D6	9/16		6452021-02	Yoke	4
T T M	D6	7/16 & 1/2	6	6480711-00	Yoke Shaft	4
	D6	1/2		6480711-00	Yoke Shaft	4
	D6	9/16		6480711-00	Yoke Shaft	4
T T M	D6	7/16 & 1/2	7	6457761-00	Equalizer Sheave	4
	D6	1/2		6457761-00	Equalizer Sheave	4
	D6	9/16		6457761-00	Equalizer Sheave	4
T T M	D6	7/16 & 1/2	8	6431891-00	Equalizer Sheave Pin	4
	D6	1/2		6431891-00	Equalizer Sheave Pin	4
	D6	9/16		6431891-00	Equalizer Sheave Pin	4

03-110-4
FORM NO. 165-903-110

When Replacement Parts Are Needed, Order Only Yale® Factory Engineered Parts



BOTTOM BLOCK REPAIR PARTS

SECTION 1640
BOTTOM BLOCK

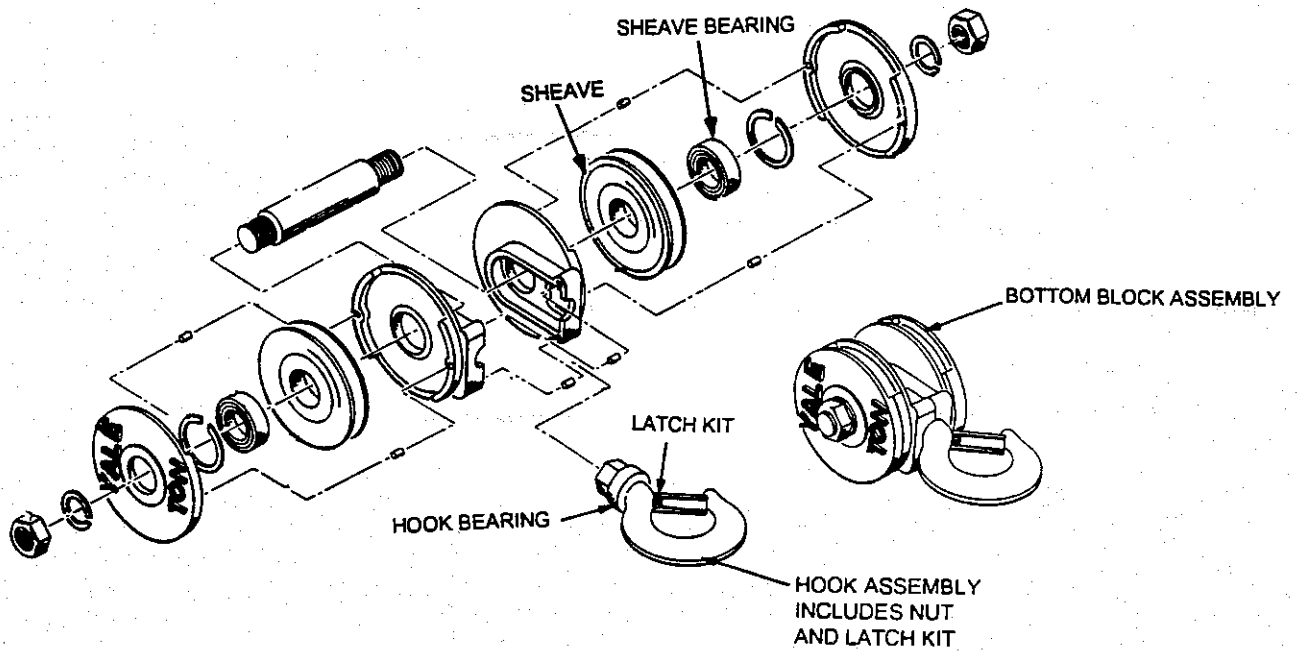

NOTE:
THE BOTTOM BLOCK ILLUSTRATED
ABOVE MAY NOT EXACTLY REPRESENT
THE ACTUAL APPEARANCE OF YOUR
BOTTOM BLOCK. HOWEVER, IT IS TYPICAL.

NOTE:
FOR REPLACEMENT, SEE PARTS LIST IN FRONT OF PARTS MANUAL. FOR PARTS NOT LISTED
CONTACT THE FACTORY.

When Replacement Parts Are Needed, Order Only YALE Factory Engineered Parts

TROLLEY MOTOR 6489431-00

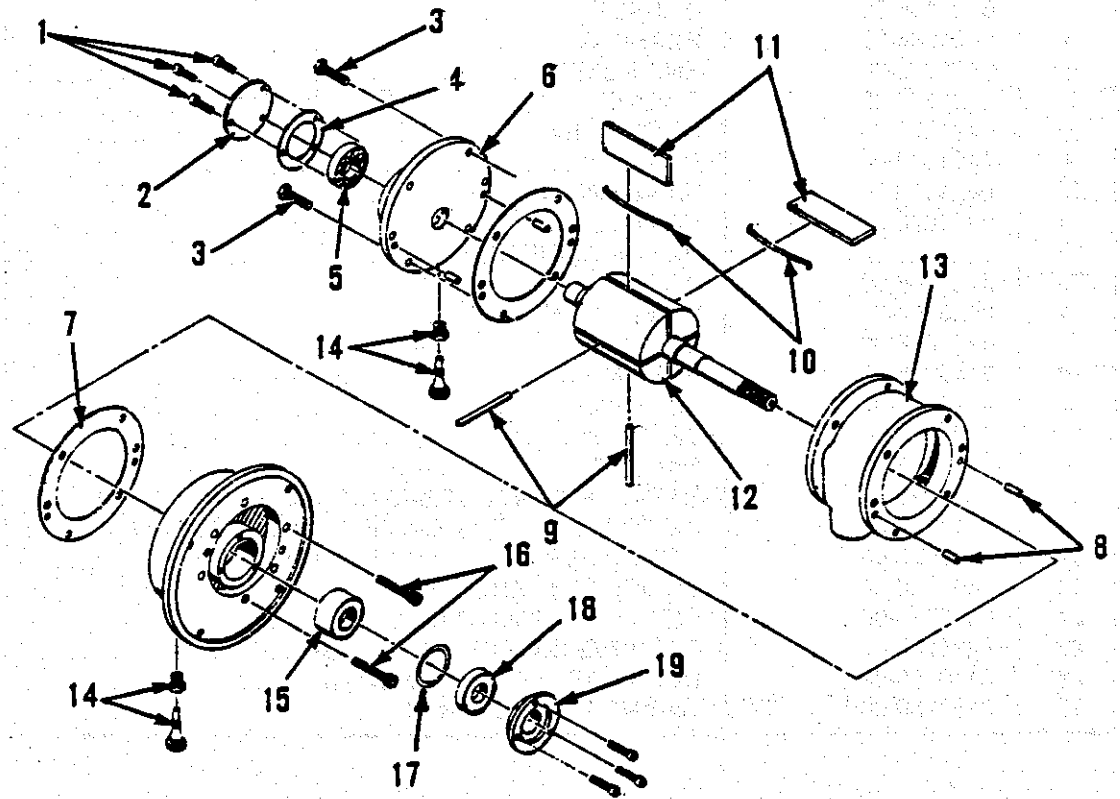

FORM NO. 165-910-004

When Replacement Parts Are Needed, Order Only Yale® Factory Engineered Parts

OCTOBER 1984

AW SERIES

SECTION 3310

AIR MOTOR AND ADAPTER ASM.
AW SERIES

ITEM	PART NO. 1/2 PIPE	DESCRIPTION	QTY.
	6405854-00	MOTOR ASSEMBLY	1
1	6453748-00	SCREW	6
2	6421178-00	END CAP	1
3	6453758-00	SCREW	6
4	6421188-00	GASKET	1
5	6421088-00	BEARING	1
6	6421028-00	END PLATE	1
7	6421138-00	GASKET	2
8	6421128-00	DOWEL PIN	4
9	6421068-00	PUSH PIN	2
10	6421058-00	VANE SPRING	4
11	6421048-00	VANE	4
12		ROTOR ASSEMBLY	1
13	6421008-00	BODY	1
14	6453768-00	OILER ASSEMBLY	2
15	6421078-00	BEARING	1
16	6453778-00	SCREW	6
17	6421198-00	"O" RING	1
18	6421118-00	SEAL	1
19	6421168-00	END CAP	1
20	6421228-00	REPAIR KIT (INCL. ITEMS 4, 5, 7, 9, 10, 11, 15, 17 & 18)	1
21	6414140-00	MOTOR ADAPTER ASM. (INCL. ITEMS 22 through 27)	1
22	6405083-00	MOTOR ADAPTER (NOT SHOWN)	1
23	0655796-00	SCREW (NOT SHOWN)	4
24	0515197-00	RETAINING RING (NOT SHOWN)	1
25	0325737-00	BEARING (NOT SHOWN)	1
26	0150290-00	LOCKWASHER (NOT SHOWN)	4
27	0150288-00	WASHER (NOT SHOWN)	4

FORM NO. 165-910-004

When Replacement Parts Are Needed, Order Only Yale® Factory Engineered Parts

AW SERIES

2

OCTOBER 1984

Yale Hoisting Equipment

USER INFORMATION PAGE

IMPORTANT
SELECT COMPONENT ASSEMBLY
NUMBER FROM PARTS LIST IN FRONT
COVER BEFORE SELECTING
REPLACEMENT ITEM NUMBER

SECTION 3320
ST GEARING

1. FIND TWO DIGIT IDENTIFICATION CODE STAMPED ON TOP OF THE TROLLEY GEARCASE.

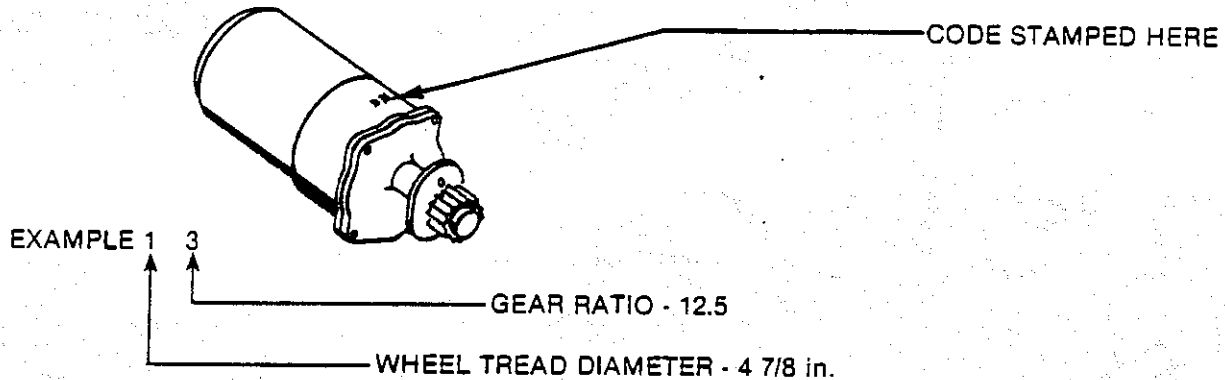

2. SEE TABLE BELOW FOR TROLLEY SPEED AND REPAIR PARTS PAGE NUMBER.

3. TURN TO SECTION 3320 PAGES 2, 3 & 4 FOR REPAIR PART INFORMATION

NOTE: CATALOG SPEEDS ARE BASED ON 1800 RPM MOTORS.

Complete ST Gearing Assembly							
Standard EW Selection	Exp. Proof * EW Selection	Standard AW Selection	Two Digit Code	Tread Diameter (in.)	Gear Ratio	Trolley Speed	Section Page No.
6460072-11	6462142-11	6459472-11	11	4 7/8	18.06	25	3320 Page 4
6460072-12	6462142-12	6459472-12	12	4 7/8	13.58	30	
6460072-13	6462142-13	6459472-13	13	4 7/8	12.5	35	
6460072-14	6462142-14	6459472-14	14	4 7/8	9.4	50	
6460072-15	6462142-15	6459472-15	15	4 7/8	7.87	55	
6460072-16	6462142-16	6459472-16	16	4 7/8	5.45	70	
6460072-21	6462142-21	6459472-21	21	6	18.06	35	3320 Page 4
6460072-22	6462142-22	6459472-22	22	6	13.58	50	
6460072-23	6462142-23	6459472-23	23	6	12.5	55	
6460072-24	6462142-24	6459472-24	24	6	9.4	70	
6460072-25	6462142-25	6459472-25	25	6	7.87	80	
6460072-26	6462142-26	6459472-26	26	6	5.45	120	
6460072-31	6462142-31	6459472-31	31	8	18.06	35	3320 Page 4
6460072-32	6462142-32	6459472-32	32	8	13.58	45	
6460072-33	6462142-33	6459472-33	33	8	12.5	50	
6460072-34	6462142-34	6459472-34	34	8	9.4	70	
6460072-35	6462142-35	6459472-35	35	8	7.87	80	
6460072-36	6462142-36	6459472-36	36	8	5.45	115	
6460072-41	6462142-41	6459472-41	41	10	18.06	35	3320 Page 4
6460072-42	6462142-42	6459472-42	42	10	13.58	45	
6460072-43	6462142-43	6459472-43	43	10	12.5	50	
6460072-44	6462142-44	6459472-44	44	10	9.4	70	
6460072-45	6462142-45	6459472-45	45	10	7.87	80	
6460072-46	6462142-46	6459472-46	46	10	5.45	115	

* C-Face Mounting

FORM NO. 165-912-113

When Replacement Parts Are Needed, Order Only Yale® Factory Engineered Parts

SECTION 3320

GEARING
ST SERIES

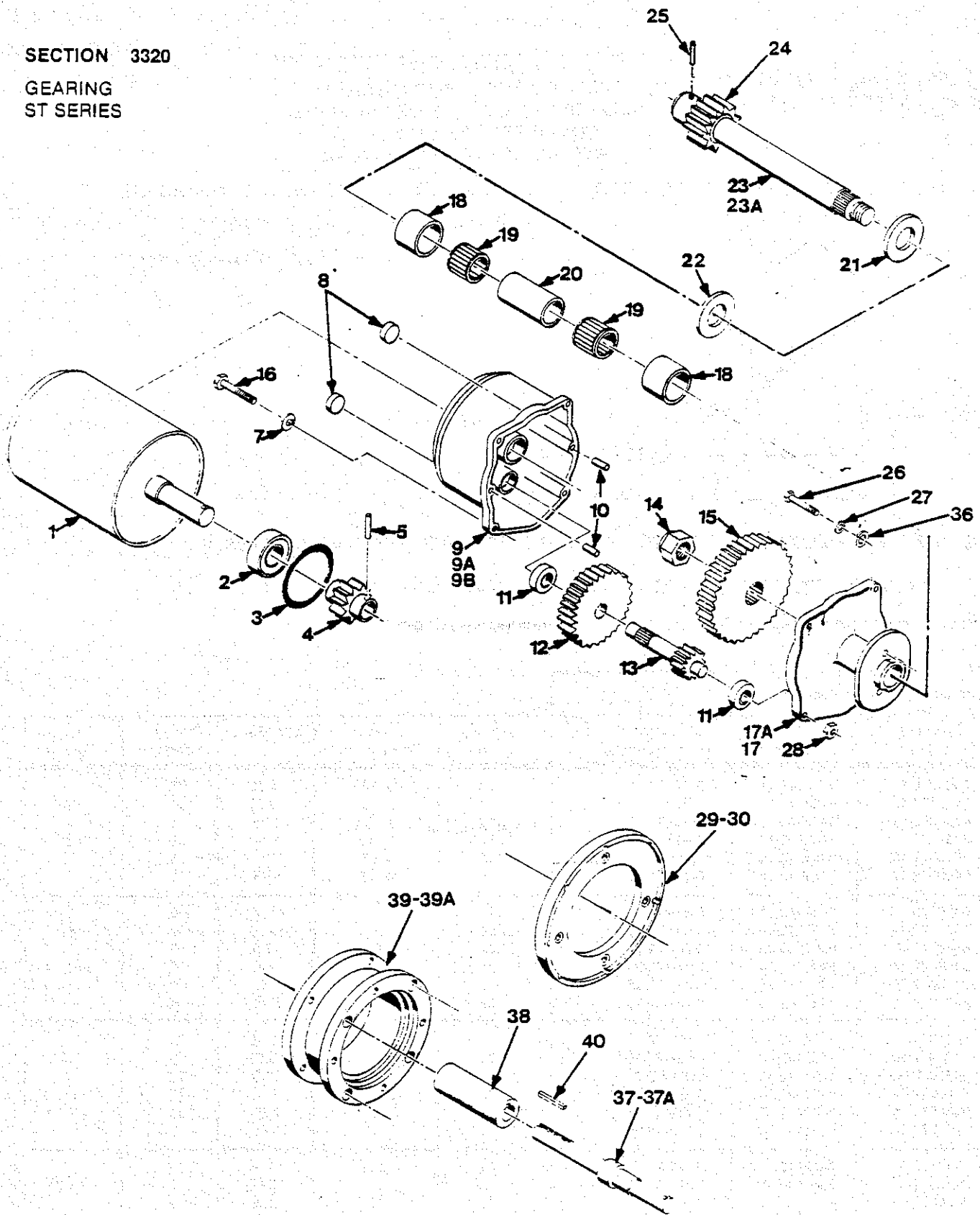

FORM NO. 165-912-115

When Replacement Parts Are Needed, Order Only Yale® Factory Engineered Parts
EW / AW SERIES

ITEM	PART NO.	DESCRIPTION	QTY.
1	SEE PARTS LIST	MOTOR	1
2	0325737-00	MOTOR BEARING	1
3	0193248-00	"O" RING	1
4	SEE TABLE 2	PINION	1
5	SEE TABLE 2	PINION PIN	1
6	0146723-00	SCREW (CONTROL BOX MTG. ONLY)	2
7	0150264-00	WASHER	4
8	0230825-00	PIPE PLUG	2
9	0192483-00	GEARCASE FOR PARTIAL MOTOR	1
9A	5041364-00	GEARCASE FOR C-FACE MOTOR	1
9B	6499941-00	GEARCASE AIR POWERED	1
10	6400529-01	DOWEL PIN	2
11	0100850-00	BEARING	2
12	SEE TABLE 2	GEAR	1
13	SEE TABLE 2	PINION	1
14	0326590-00	LOCKNUT 5/8 - 11	1
15	SEE TABLE 2	GEAR	1
16	0570482-00	SCREW 3/8 - 16 x 1	4
17	0221092-00	GEARCASE COVER STANDARD	1
17A	6446561-00	GEARCASE COVER C-FACE & AIR POWERED	1
18	0610994-00	INNER RACE	2
19	0572813-00	NEEDLE BEARING	2
20	0317344-00	SPACER	1
21	0535816-00	WASHER	1
22	0544158-00	WASHER, THRUST BRONZE SELF LUB.	1
23	SEE TABLE 1	SHAFT	1
23A	6400851-00	PINION & SHAFT ASM. (4 7/8 WHL TREAD DIA. ONLY)	1
24	SEE TABLE 1	PINION	1
25	SEE TABLE 1	DRIVE PIN	1
26	0554650-00	SCREW 1/2 - 13 x 1 1/4	2
27	0150266-00	LOCKWASHER	2
28	0149369-00	NUT 3/8 - 16	2
29	5039344-00	ADAPTER (C-FACE MOTOR)	1
30	5039354-00	ADAPTER (GEARCASE) (C-FACE MOTOR)	1
31	0149087-00	SCREW 5/16 X 1 FLAT HD (NOT SHOWN)	4
32	0149100-00	SCREW 3/8 X 7/8 FLAT HD (NOT SHOWN)	4
33	0597191-00	SCREW 3/8 - 1 1/2 (NOT SHOWN)	4
34	0150264-00	3/8 LOCKWASHER (NOT SHOWN)	12
35	0597164-00	SCREW 5/16 X 2 1/4 (NOT SHOWN)	4
36	0161100-00	FLAT WASHER	2
37	6489361-00	PINION SHAFT (W/HORTON BRK.) AIR POWERED	1
37A	6447193-00	PINION SHAFT (W/O BRAKE) AIR POWERED	1
38	6447203-00	COUPLING (W/O BRAKE) AIR POWERED	1
39	6447213-00	ADAPTER (W/O BRAKE) AIR POWERED	1
39A	6489391-00	ADAPTER (W/HORTON BRAKE) AIR POWERED	1
40	6405431-00	KEY, DRIVE SHAFT AIR POWERED	2
41	0621437-00	SCREW 5/16 X 1 (NOT SHOWN) AIR POWERED	4
42	0150262-00	LOCKWASHER 5/16 (NOT SHOWN) AIR POWERED	4
43	0570482-00	SCREW 3/8 X 1 (NOT SHOWN) AIR POWERED	8

FORM NO. 165-912-115

When Replacement Parts Are Needed, Order Only Yale® Factory Engineered Parts

SECTION 3320

GEARING
ST SERIES

TABLE 1

	PINION SHAFT ITEM 23	PINION ITEM 24	DRIVE PIN ITEM 25
6 in. Whl Trolley	6401423-00	0588168-00 14 teeth	0559292-00
8 in. Whl Trolley	6435181-00	6415121-00 10 teeth	0157393-00
10 in. Whl Trolley	6426333-00	6415121-00 10 teeth	0157393-00

TABLE 2

TWO DIGIT CODE	WHEEL TREAD DIA.			MOTOR PINION ITEM 4	LOCK PIN ITEM 5	GEAR ITEM 12	PINION ITEM 13	GEAR ITEM 15
	4 7/8	6	8 & 10					
SPEED FPM								
11	25	-	-	0104607-00 12 teeth	0106959-00	6407531-00 52 teeth	6407511-00 12 teeth	0226396-00 50 teeth
12	30	-	-	0104607-00 12 teeth	0106959-00	6407531-00 52 teeth	6407501-00 15 teeth	0226408-00 47 teeth
13	35	-	-	0104602-00 16 teeth	0106953-00	6407541-00 48 teeth	6407511-00 12 teeth	0226396-00 50 teeth
14	50	-	-	0104602-00 16 teeth	0106953-00	6407541-00 48 teeth	6407501-00 15 teeth	0226408-00 47 teeth
15	55	-	-	0104607-00 12 teeth	0106959-00	6407531-00 52 teeth	6407521-00 22 teeth	0610986-00 40 teeth
16	70	-	-	0104602-00 16 teeth	0106953-00	6407541-00 48 teeth	6407521-00 22 teeth	0610986-00 40 teeth
21, 31, 41	-	35	35	0104607-00 12 teeth	0106959-00	6407531-00 52 teeth	6407511-00 12 teeth	0226396-00 50 teeth
22, 32, 42	-	50	45	0104607-00 12 teeth	0106959-00	6407531-00 52 teeth	6407501-00 15 teeth	0226408-00 47 teeth
23, 33, 43	-	55	50	0104602-00 16 teeth	0106953-00	6407541-00 45 teeth	6407511-00 12 teeth	0226396-00 50 teeth
24, 34, 44	-	70	70	0104602-00 16 teeth	0106953-00	6407541-00 48 teeth	6407501-00 15 teeth	0226408-00 47 teeth
25, 35, 45	-	80	80	0104607-00 12 teeth	0106959-00	6407531-00 52 teeth	6407521-00 22 teeth	0610986-00 40 teeth
26, 36, 46	-	120	115	0104602-00 16 teeth	0106953-00	6407541-00 48 teeth	6407521-00 22 teeth	0610986-00 40 teeth

-115-3

FORM NO. 165-912-115

When Replacement Parts Are Needed, Order Only Yale® Factory Engineered Parts

Yale Hoisting Equipment

SECTION 3323

REPAIR PARTS

MOTORIZED TROLLEY DRIVE (RT)

Trolley Assembly

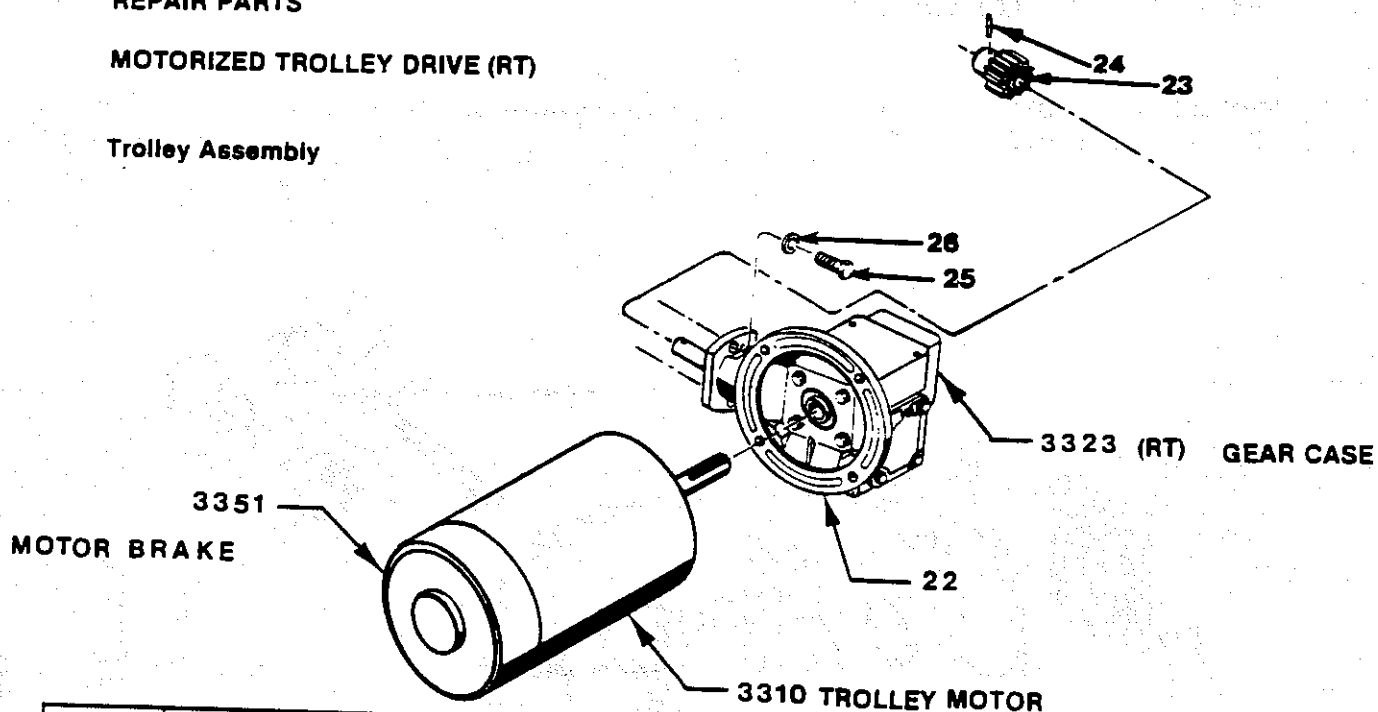

ITEM NBR	PART NUMBER	DESCRIPTION	QTY.
3323	SEE PART LIST	GEAR CASE	
3232	SEE PART LIST	RT MGT. KIT (Incl. Items 23, 24, 25 & 26)	1
22	6498053	ADAPTOR RING	1
23		PINION	1
24		GROOVE PIN	1
25		BOLT	1
26		LOCK WASHER	2
3310	SEE PART LIST*	MOTOR	2
3351	SEE PART LIST	MOTOR BRAKE	1

* When Ordering Motors Give Complete Data on Motor Nameplate.

PAT-005

When Replacement Parts Are Needed, Order Only Yale® Factory Engineered Parts

AUGUST 1987

EW SERIES

Yale Hoisting Equipment

SECTION 3323

REPAIR PARTS

MOTORIZED TROLLEY DRIVE (RT)

TROLLEY GEAR BOX
133 and 175 SERIES

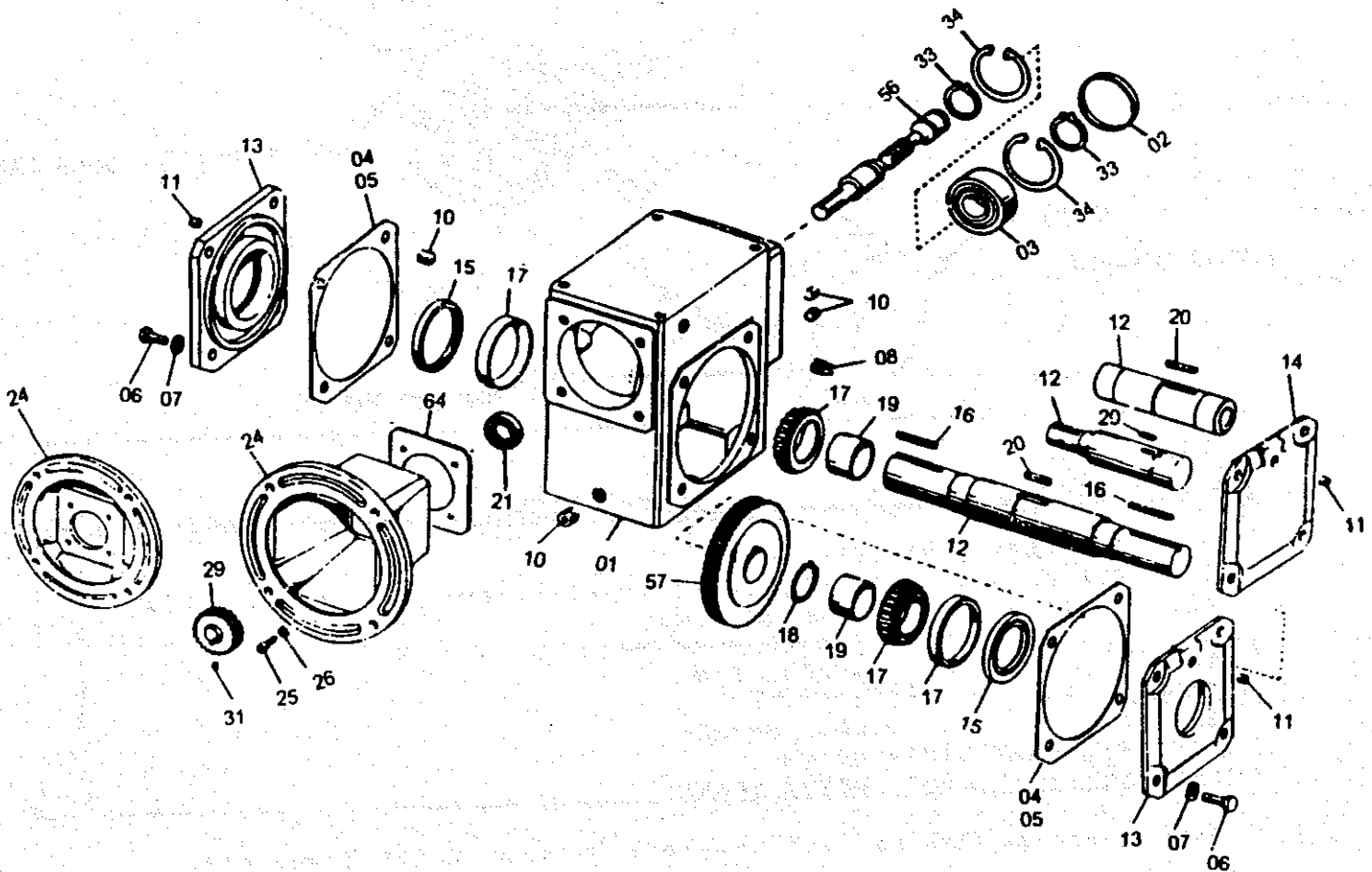

****NOTE** When ordering parts give complete name plate data.
*Refer to parts list in front of manual for gear box part number.

When Replacement Parts Are Needed, Order Only Yale® Factory Engineered Parts

OCTOBER 1994

EW SERIES

RT GEAR BOX

6462923** Series 133	
ITEM **	DESCRIPTION
644426-01	HOUSING
644426-02	END COVER
644426-03	BEARING
644426-04	SHIM (.019 THICK)
644426-05	SHIM (.007 THICK)
644426-06	CAPSCREW
644426-07	LOCKWASHER
644426-09	VENT PLUG
644426-10	PIPE PLUG
644426-11	PIPE PLUG
644426-12	OUTPUT SHAFT
644426-13	SEAL CAGE
644426-14	END COVER
644426-15	OIL SEAL
644426-16	KEY
644426-17	BEARING
644426-18	LOCK RING
644426-19	SPACER
644426-20	KEY
644426-21	OIL SEAL
644426-22	KEY
644426-24	MOTOR FLANGE
644426-25	CAPSCREW
644426-26	LOCKWASHER
644426-30	COUPLING HUB (MOTOR)
644426-31	SETSCREW
644426-33	LOCK RING
644426-34	LOCK RING
** -56	WORM - SEE CHART
** -57	GEAR - SEE CHART
644426-64	GASKET
NOTE: WHEN ORDERING REPLACEMENT PARTS, SPECIFY I.D. NUMBER, ITEM NUMBER AND PART DESCRIPTION.	

Worm & Gear

Ratio	Worm No.	Gear No.
5-1	6444706-01	6444706-02
10-1	6444706-03	6444706-04
15-1	6444706-05	6444706-06
20-1	6444706-07	6444706-08
30-1	6444706-09	6444706-10
40-1	6444706-11	6444706-12
50-1	6444706-13	6444706-14
60-1	6444706-15	6444706-16

When Replacement Parts Are Needed, Order Only Yale® Factory Engineered Parts

Yale® Hoists

RT GEAR BOX

6467093** Series 175	
ITEM **	DESCRIPTION
6449826-01	HOUSING
6449826-02	END COVER
6449826-03	BEARING
6449826-04	SHIM (.019 THICK)
6449826-05	SHIM (.007 THICK)
6449826-06	CAPSCREW
6444426-07	LOCKWASHER
6444426-09	VENT PLUG
6444426-10	PIPE PLUG
6444426-11	PIPE PLUG
6449826-12	OUTPUT SHAFT
6449826-13	SEAL CAGE
6449826-14	END COVER
6449826-15	OIL SEAL
6444426-16	KEY
6449826-17	BEARING
6449826-18	LOCK RING
6449826-19	SPACER
6449826-20	KEY
6444426-21	OIL SEAL
6444426-24	MOTOR FLANGE
6449826-25	CAPSCREW
6449826-26	LOCKWASHER
6449826-30	COUPLING HUB (MOTOR)
6449826-31	SETSCREW
6449826-33	LOCK RING
6449826-34	LOCK RING
** -56	WORM - SEE CHART
** -57	GEAR - SEE CHART
6444426-64	GASKET
NOTE: WHEN ORDERING REPLACEMENT PARTS, SPECIFY I.D. NUMBER, ITEM NUMBER AND PART DESCRIPTION.	

Worm & Gear

RATIO	WORM NO.	GEAR NO.
5-1	# 645174601	# 645174602
10-1	# 645174603	# 645174604
15-1	# 645174605	# 645174606
20-1	# 645174607	# 645174608
30-1	# 645174609	# 645174610
40-1	# 645174611	# 645174612
50-1	# 645174613	# 645174614
60-1	# 645174615	# 645174616

TROLLEY HANDWHEEL GROUP

EW / AW SERIES GT - GEARED TROLLEY
4 7/8" & 6" TREAD DIAMETER WHEELS

IMPORTANT
SELECT COMPONENT ASSEMBLY
NUMBER FROM PARTS LIST IN FRONT
COVER BEFORE SELECTING
REPLACEMENT ITEM NUMBER

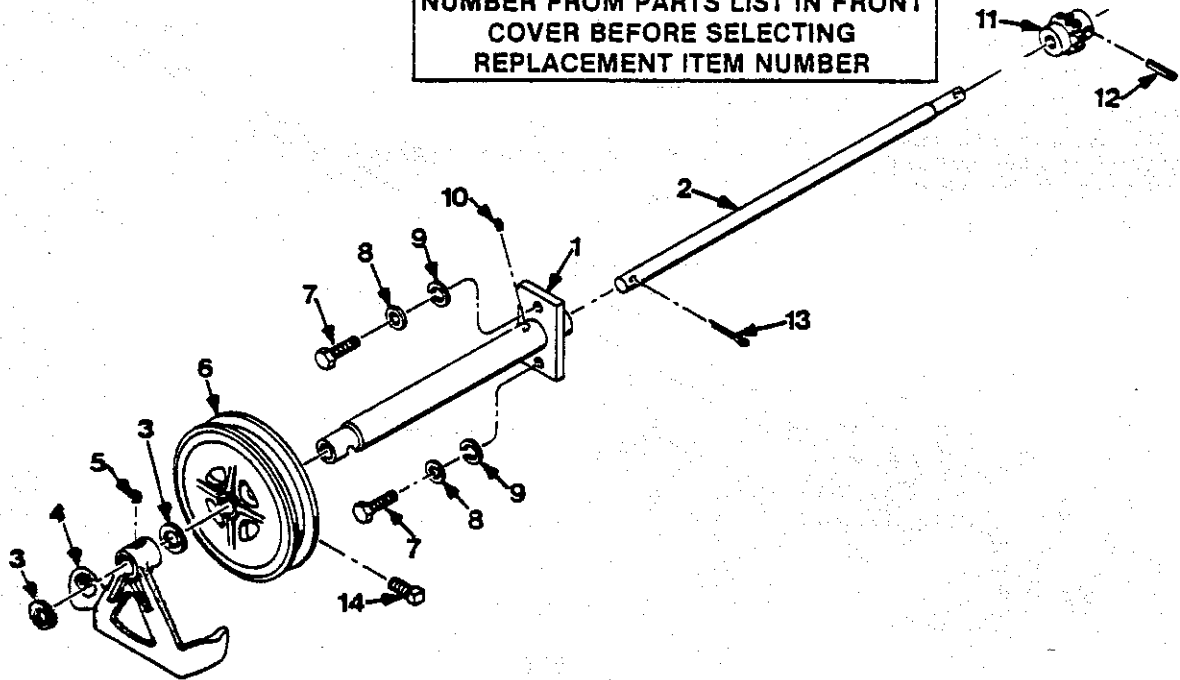

TABLE

4 7/8" TREAD DIAMETER WHEELS				
ASSEMBLY NUMBER	ITEM 1 EXTENSION	ITEM 2 SHAFT	ITEM 11 PINION	ITEM 12 ROLL PIN
6434722-01	0664454-00	6456491-01	0250202-00	0230207-00
6434722-02	6437154-00	6456491-02	↓	↓
6434722-03	6439061-00	6456491-03	↓	↓
6434722-04	6452881-01	6456491-04	↓	↓
6434722-05	6452881-02	6456491-05	↓	↓
6434722-06	6442576-00	6456491-06	↓	↓
6434722-07	6452881-03	6456491-07	0250202-00	0230207-00

6" TREAD DIAMETER WHEELS				
ASSEMBLY NUMBER	ITEM 1 EXTENSION	ITEM 2 SHAFT	ITEM 11 PINION	ITEM 12 ROLL PIN
6434732-01	0664454-00	0664456-00	0588168-00	0559292-00
6434732-02	6437154-00	6430283-00	↓	↓
6434732-03	6439061-00	6439051-00	↓	↓
6434732-04	6452881-01	6452891-01	↓	↓
6434732-05	6452881-02	6452881-02	↓	↓
6434732-06	6442576-00	6446733-00	↓	↓
6434732-07	6452881-03	6452891-03	0588168-00	0559292-00

ITEM NUMBER	PART NUMBER	DESCRIPTION	QTY.
3	0250668-00	WASHER	2
4	0588165-00	GUIDE	1
5	0185584-00	FITTING	1
6	0111132-00	HANDWHEEL	1
7	0554850-00	1/2-13 X 1 1/4 HEX HEAD SCREW	2
8	0142209-00	WASHER	2
9	0150266-00	LOCKWASHER	2
10	0227845-00	FITTING	1
11	SEE TABLE	PINION	1
12	SEE TABLE	ROLL PIN	1
13	0381400-00	COTTER PIN	1
14	0388054-00	7/16-14X1 SQUARE HEAD SCREW	1
15	0033730-00	HAND CHAIN (NOT SHOWN) SPECIFY LENGTH	

165-912-070

When Replacement Parts Are Needed, Order Only Yale Factory Engineered Parts.

SECTION 3330

TROLLEY HANDWHEEL GROUP
 EW / AW SERIES GT - GEARED TROLLEY
 8 & 10" TREAD DIAMETER WHEELS

IMPORTANT
SELECT COMPONENT ASSEMBLY
NUMBER FROM PARTS LIST IN FRONT
COVER BEFORE SELECTING
REPLACEMENT ITEM NUMBER

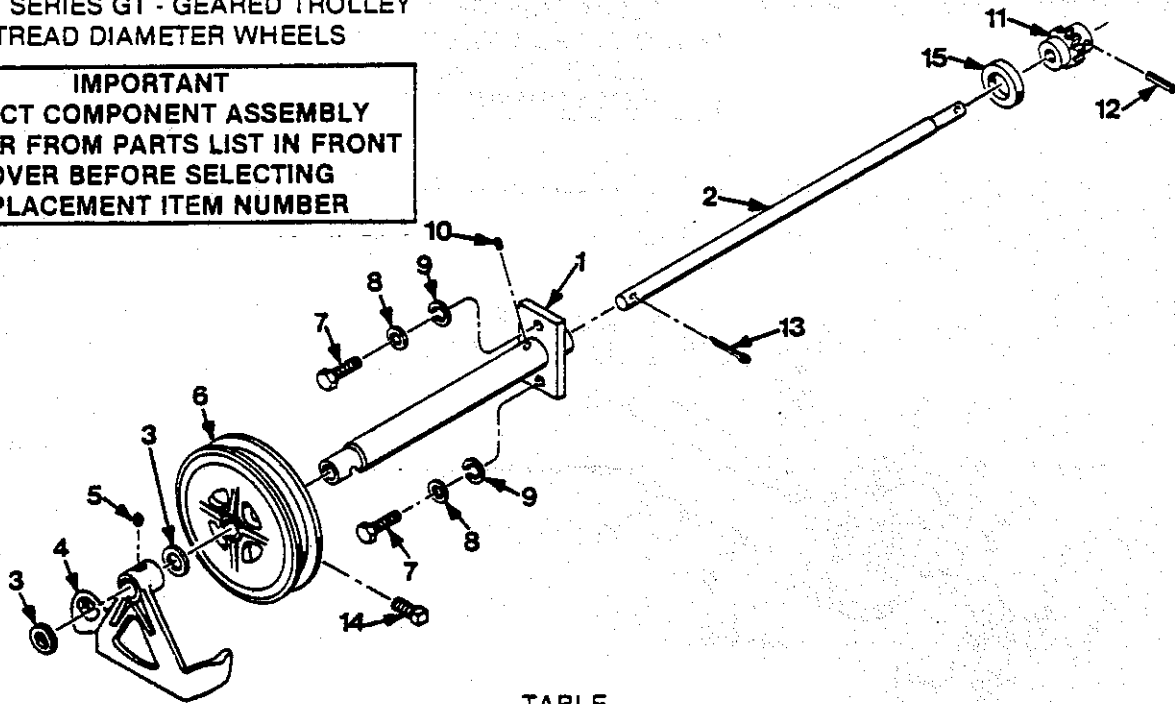

TABLE

ASSEMBLY NUMBER	ITEM 1 EXTENSION	ITEM 2 SHAFT	LIFT
6434742-01	6445804-01	6436753-00	2
6434742-02	0664820-00	0665191-00	3
6434742-03	6443384-00	6419981-06	4
6434742-04	6420554-00	6410351-00	5
6434742-05	6444194-01	6419981-03	6
6434742-06	6444194-02	6419981-04	7
			8

ITEM NUMBER	PART NUMBER	DESCRIPTION	QTY.
1	SEE TABLE	EXTENSION ITEM 1	1
2	SEE TABLE	SHAFT ITEM 2	1
3	0250664-00	WASHER	3
4	0591410-00	GUIDE	1
5	0185584-00	FITTING	1
6	0535795-00	HANDWHEEL	1
7	0596946-00	1/2-13 X 1 1/2 HEX HEAD SCREW	2
8	0142209-00	WASHER	2
9	0150266-00	LOCKWASHER	2
10	0227845-00	FITTING	1
11	0589890-00	PINION	1
12	0230236-00	ROLL PIN	1
13	0154214-00	COTTER PIN	1
14	0388010-00	1/2-13 SQUARE HEAD SCREW	1
15	0665193-00	SPACER	1
16	0033730-00	HAND CHAIN (NOT SHOWN) SPECIFY LENGTH	1

165-912-073

When Replacement Parts Are Needed, Order Only Yale Factory Engineered Parts.

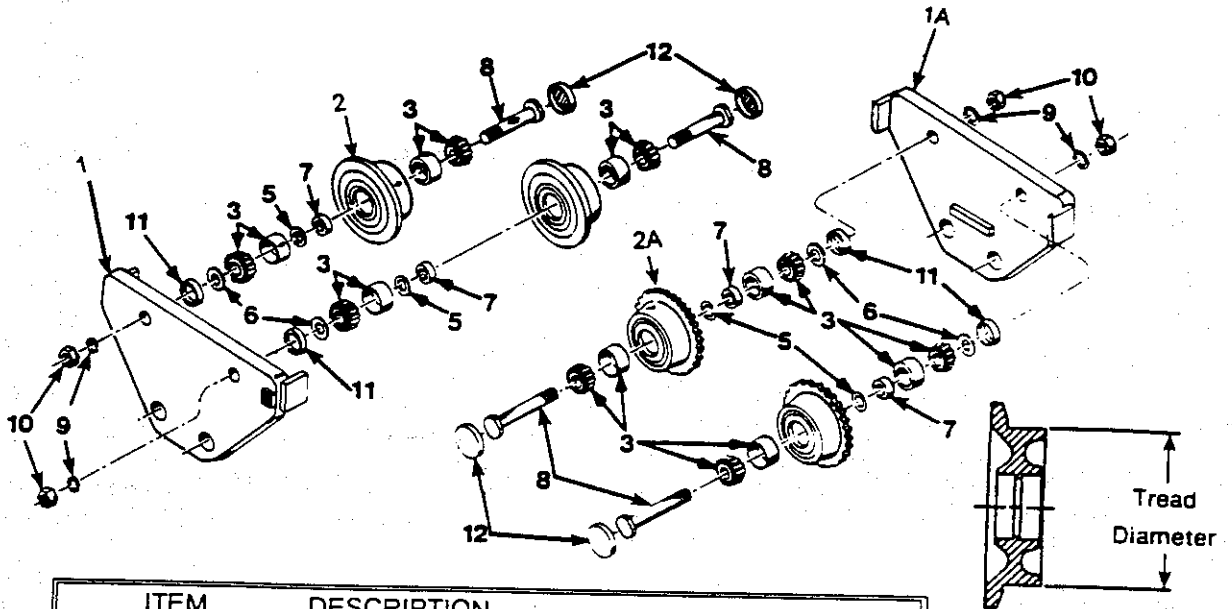

ITEM	DESCRIPTION
1	SIDEPLATE PLAIN
1A	SIDEPLATE GEARED
2	WHEEL PLAIN
2A	WHEEL GEARED
3	BEARING
4	AXLE GROUP INC. ITEMS 3,5,6,7,8,9,10,11,12
5	BEARING SHIM
6	BEARING SPACER
7	WHEEL SPACER
8	AXLE
9	LOCKWASHER
10	AXLE NUT
11	DUST COVER INSIDE (8 & 10 IN TD ONLY)
12	DUST COVER OUTSIDE (8 & 10 IN TD ONLY)

Wheel Description

Wheel 6.0 p - ball

Tread Dia _____

Plain _____

Tread Type _____

NOTE: THE TROLLEY ILLUSTRATED ABOVE MAY NOT EXACTLY REPRESENT THE ACTUAL APPEARANCE OF YOUR TROLLEY HOWEVER, IT IS TYPICAL.

NOTE: FOR REPAIR PARTS, REFER TO PARTS LIST IN FRONT OF THE PARTS MANUAL.

When Replacement Parts Are Needed, Order Only Yale[®] Factory Engineered Parts.

SECTION 3475
TROLLEY GUIDE ROLLER

**IMPORTANT
SELECT COMPONENT ASSEMBLY
NUMBER FROM PARTS LIST
BEFORE SELECTING
REPLACEMENT ITEM NUMBER**

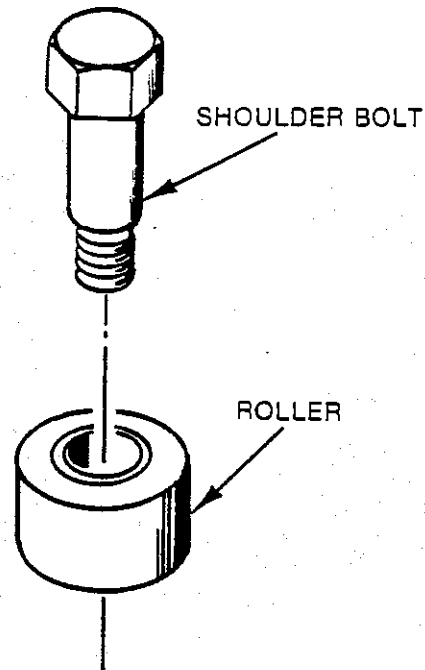

COMPONENT NUMBER	ROLLER DIAMETER	MATERIAL	ROLLER PART NUMBER	SHOULDER BOLT PART NO.
6446012-01	2	STANDARD	6481681-01	6481371-00
6446012-02	1 3/4	STANDARD	6481681-02	6481371-00
6452562-01	2	BRONZE	6491571-01	6481371-00
6452562-02	1 3/4	BRONZE	6491571-02	6481371-00

FORM NO. 165-912-116

When Replacement Parts Are Needed, Order Only Yale® Factory Engineered Parts

OCTOBER, 1984

EW/AW SERIES

Duff-Norton Yale® Hoists

SECTION 6210
HOIST MOTOR

RM110, 210, 310, 410 Air Motors

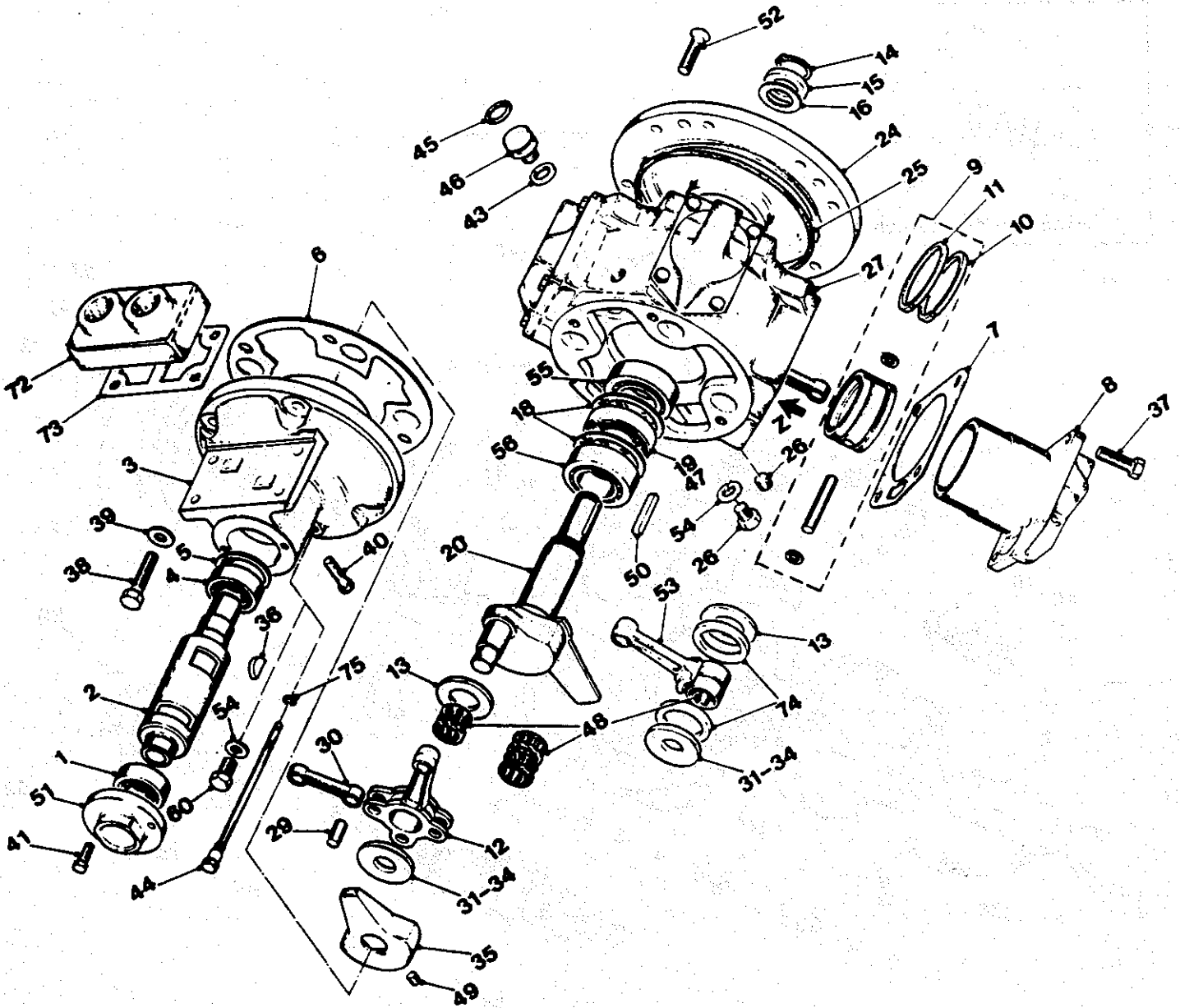

When Replacement Parts Are Needed, Order Only Yale® Factory Engineered Parts

Duff-Norton Yale® Hoists

SECTION 6210
HOIST MOTOR

RM 510 and 610 Air Motors

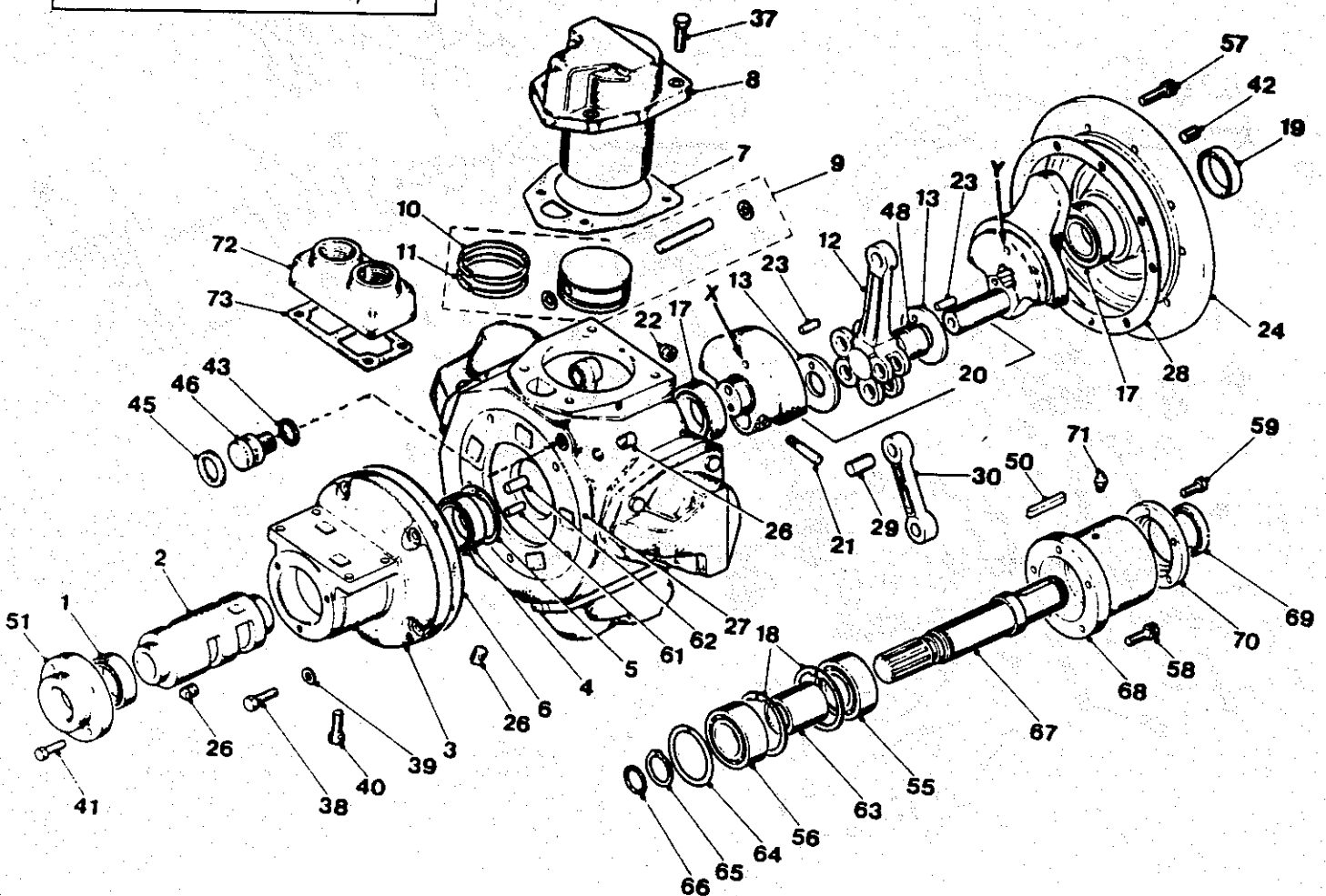
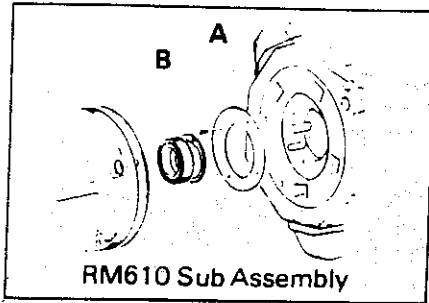

When Replacement Parts Are Needed, Order Only Yale® Factory Engineered Parts

Duff-Norton Yale® Hoists

RM110 210 310 410 510 AND 610 AIR MOTORS

110	210	310	410	510	610
PART NO.	PART NO.	PART NO.	PART NO.	PART NO.	PART NO.
6492854-	6492864-	6492874-	6492884-	6492894-	6492904-

PART NUMBER = BASE NUMBER + ITEM NUMBER

ITEM	DESCRIPTION	QTY	MOTOR SIZE					
			110	210	310	410	510	610
1	ROTARY VALVE BRG. (OUTER)	1	110	210	310	410	510	610
2	ROTARY VALVE	1	110	210	310	410	510	610
3	ROTARY VALVE HOUSING	1	110	210	310	410	510	610
4	ROTARY VALVE BRG. (INNER)	1	110	210	310	410	510	610
5	ROTARY VALVE BRG. CIRCLIP	1	110	210	310	410	510	610
6*	ROTARY VALVE BRG. GASKET	1	110	210	310	410	510	610
7*	CYLINDER GASKET	4-5	110	210	310	410	510	610
8	CYLINDER	4-5	110	210	310	410	510	610
9	PISTON ASSEMBLY	4-5	110	210	310	410	510	610
10*	COMPRESSION RING	1	110	210	310	410	510	610
11*	OIL CONTROL RING	4-5	110	210	310	410	510	610
12	KING ROD	1	—	210	310	410	510	610
13	CRANKSHAFT SPACER	1	110	210	310	410	510	610
14	CRANKSHAFT CIRCLIP	1	110	210	310	410	—	—
15	CRANKSHAFT SPACER	1	110	210	310	410	—	—
16	CRANKSHAFT SPACER SHIM	5	110	210	310	410	—	—
17	CRANKSHAFT BEARING	2	—	—	—	—	510	610
18	CRANKSHAFT BEARING CIRCLIP	2	—	210	310	410	510	610
19*	CRANKSHAFT OIL SEAL	1	110	210	310	410	510	610
20	STD CRANKSHAFT ASSEMBLY	1	110	210	310	410	510	610
21	CRANK BOLT	1	—	—	—	—	510	610
22	CRANK NUT	1	—	—	—	—	510	610
23	SPRING DOWEL	2	—	—	—	—	510	610
24	STD FLANGE PLATE	1	110	210	310	410	510	610
25*	FLANGE PLATE SEAL	1	110	210	310	410	—	—
26	PLUG	1-3	110	210	310	410	510	610
27	ENGINE CASE	1	110	210	310	410	510	610
28*	ENGINE CASE GASKET (520)	1	—	—	—	—	510	610
29	QUEEN ROD PIVOT	3-4	—	210	310	410	510	610
30	QUEEN ROD	3-4	—	210	310	410	—	—
31	CRANK SPACER SELECT	1	110	210	310	410	—	—
32	CRANK SPACER ON	1	110	—	310	410	—	—
33	CRANK SPACER ASSEMBLY	1	110	210	310	410	—	—
34	CRANK SPACER	1	110	210	—	—	—	—
35	BALANCE WEIGHT	1	110	210	310	410	—	—
36	WOODRUFF KEY	1	110	210	310	410	—	—
37	CYLINDER BOLTS	16-20	110	210	310	410	510	610
38	VALVE HOUSING BOLTS	4-10	110	210	—	410	510	610

When Replacement Parts Are Needed, Order Only Yale® Factory Engineered Parts

110	210	310	410	510	610
PART NO.	PART NO.	PART NO.	PART NO.	PART NO.	PART NO.
6492854-	6492864-	6492874-	6492884-	6492894-	6492904-

PART NUMBER = BASE NUMBER + ITEM NUMBER

ITEM	DESCRIPTION	QTY	MOTOR SIZE					
			110	210	310	410	510	610
39	WASHER FOR ITEM 38	4-10	—	210	—	—	510	610
40	ADAPTER PLATE BOLTS	4	110	210	310	410	510	610
41	EXHAUST COVER BOLTS	2-4	110	210	310	410	510	610
42	FLANGE PLUGS	5	—	—	—	—	510	610
43*	BREATHER PLUG SEAL	1	110	210	310	410	510	610
44	DIPSTICK (VERTICAL MTG)	1	110	210	310	—	—	—
45	SEAL (TRANSIT ONLY)	1	110	210	310	410	510	610
46	BREATHER PLUG	1	110	210	310	410	510	610
47	OIL SEAL CARRIER	1	—	—	—	410	—	—
48	NEEDLE BEARING	1-2	110	210	310	410	510	610
49	GRUB SCREW	1-5	110	210	310	410	—	—
50	KEY	1	—	210	310	410	510	610
51	ROTARY VALVE EXHAUST COVER	1	110	210	310	410	510	610
52	COUNTERSUNK FLANGE BOLTS	4-8	110	210	310	410	—	—
53	CONN. ROD (SLIPPER TYPE)	4	110	—	—	—	—	—
54	NYLON WASHER	1	—	—	—	410	—	—
55	OUTPUT SHAFT BRG (OUTER)	1	110	210	310	410	510	610
56	OUTPUT SHAFT BRG (INNER)	1	—	210	310	410	510	610
57	FLANGE PLATE CAP SCREW	10	110	210	310	410	510	610
58	OUTPUT HOUSING BOLTS	5	—	—	—	—	510	610
59	OUTPUT HSG COVER BOLTS	5	—	—	—	—	510	610
60	OIL LEVEL PLUG	1	110	210	310	410	—	—
61	DRIVE PIN (DIA. 10MM)	1	—	—	—	—	510	610
62	DRIVE PIN (DIA. 12MM)	1	—	—	—	—	510	610
63	OUTPUT SHAFT BRG. SPACER	1	—	—	—	—	510	610
64	OUTPUT SHAFT SPRING RING	1	—	—	—	—	510	610
65	OUTPUT SHAFT CIRCLIP	1	—	—	—	—	510	610
66*	OUTPUT SHAFT SEAL	1	—	—	—	—	510	610
67	OUTPUT SHAFT	1	—	—	—	—	510	610
68	OUTPUT SHAFT HOUSING	1	—	—	—	—	510	610
69*	OUTPUT SHAFT OIL SEAL	1	—	—	—	—	510	610
70	OUTPUT SHAFT HSG. COVER	1	—	—	—	—	510	610
71	OUTPUT SHAFT GREASE NIPPLE	1	—	—	—	—	510	610
72	INLET ADAPTER PLATE	1	110	210	310	410	510	610
73*	INLET ADAPTER PLATE GASKET	1	110	210	310	410	510	610
74	RETAINING RING	2	110	—	—	—	—	—
75*	DIPSTICK SEAL	1	110	210	310	—	—	—
76	SEAL KIT	1	110	210	310	410	510	610

NOTE: SEAL KIT INCLUDES ALL ITEMS MARKED WITH *

When Replacement Parts Are Needed, Order Only Yale® Factory Engineered Parts

NOTE! When first running the motor some light oil should be injected into the inlet connection to ensure adequate lubrication until the airline lubrication is established.

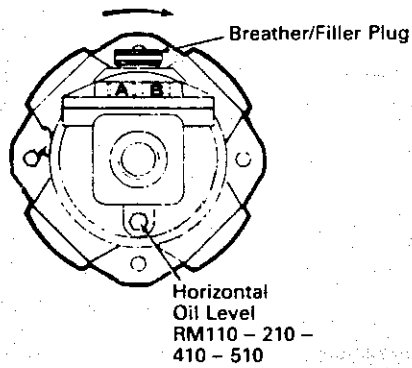

Fig. 1
horizontal

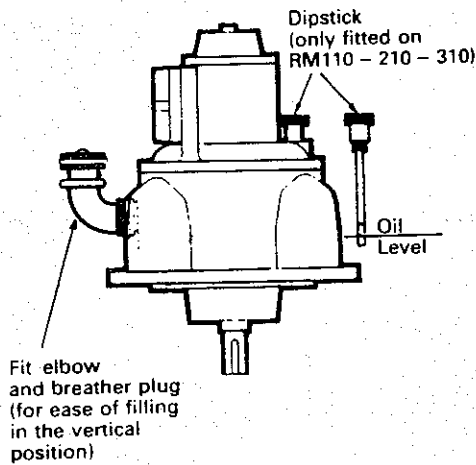

Fig. 2
vertical

Shaft rotation is shown with inlet at 'A'
Reverse rotation is obtained with inlet at 'B'

Motor Mounting Positions

Fit spacing washer such that A-B = 0.25 to 0.50mm (0.01 to 0.02in.) clearance

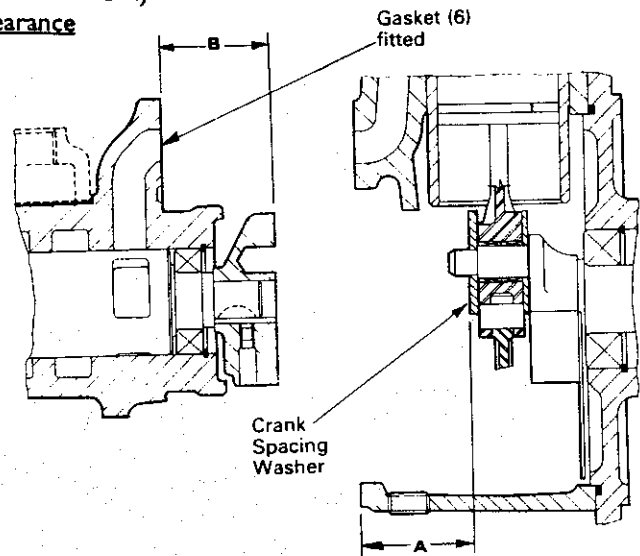

FIG. 3

Crank Spacing Washers

RM 110	RM 210	RM 310	RM 410
1 .85 (.073)	2 .64 (.104)	3 .24 (.128)	2 .5 (.099)
2 .03 (.080)	3 .25 (.128)	3 .66 (.144)	3 .0 (.120)
2 .34 (.092)	3 .66 (.144)	4 .06 (.160)	4 .0 (.157)
2 .64 (.104)			

Dimensions are in millimeters (and inches)

Spacing Diagram

Spacing Diagram

Piston Ring Clamp Details

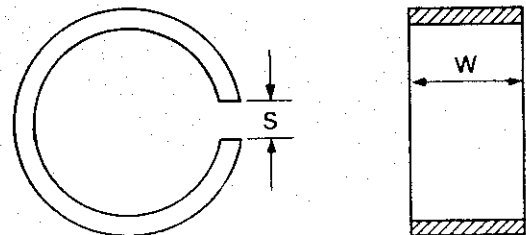

	W	S
RM210	32 (1.25)	25 (1.0)
RM310	45 (1.75)	16 (.625)

NOTE: These items can be cut from an old cylinder

Yale Hoisting Equipment

ITEM	STATION QUANTITY	2-STATION	4-STATION	6-STATION
		PENDANT ASSEMBLY (includes items A thru G)	6459332-00	6459342-00
A	Pipe Red. Bush 1/4 to 1/8	6410298-00	6410298-00	6410298-00
B	1/4 Tube Male Conn. 1/8 NP	5041138-00	5041138-00	5041138-00
C	Clamp Crosby G426 1/8 In.	6455918-00	6455918-00	6455918-00
D	Splice Sleeve 1/8 Swag	6455928-00	6455928-00	6455928-00
E	Plate For OSHA Decal	6442303-00	6442303-00	6442303-00
F	Decal, Warning	6438123-00	6438123-00	6438123-00
G	PENDANT CONTROL (HANDLE & VALVE ASSEMBLY CONSISTS OF ITEM 1 THRU 27(See Back) HANDLE & VALVE ASM.-SEALS & GASKET KIT	6499891-02 6499931-10	6499891-04 6499931-10	6499891-06 6499931-10

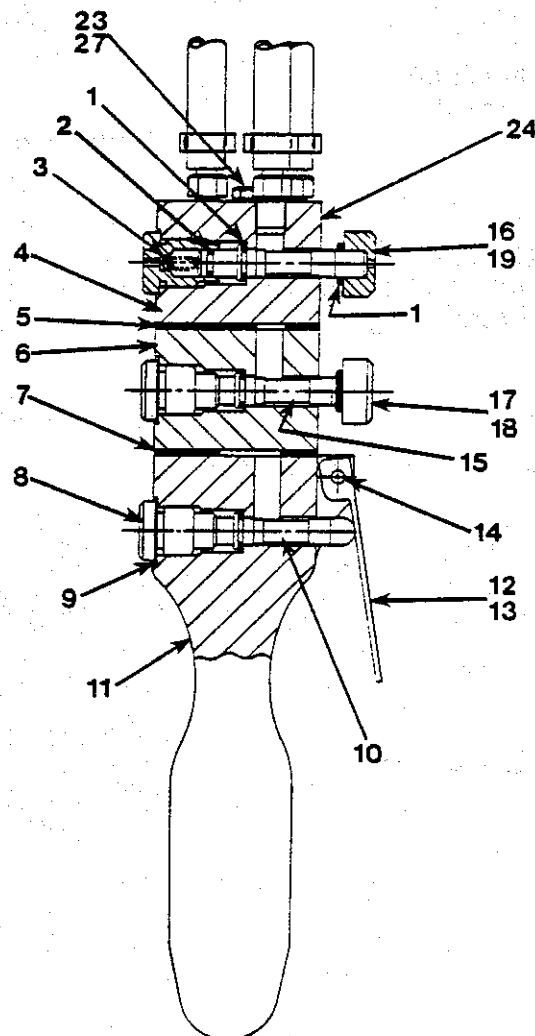

When Replacement Parts Are Needed, Order Only Yale® Factory Engineered Parts

SECTION 6715

PENDANT ASSEMBLY

AW PENDANT HANDLES

ITEM NO.	DESCRIPTION	PENDANT CONTROL		
		2 STATION QTY.	4 STATION QTY.	6 STATION QTY.
1	"O" RING 5/16" ID 7/16" OD	2	6	10
2	"O" RING 1/4" ID 3/8" OD	2	4	6
3	COMPRESSION SPRING	2	4	6
4	TOP BODY		1	1
5	GASKET			1
6	INTERMEDIATE BODY			1
7	GASKET		1	1
8	VALVE PLUG	2	4	6
9	WASHER (6MM)		2	2
10	PLUNGER (LEVER TYPE)	2	2	2
11	HANDLE	1	1	1
12	RAISE LEVER	1	1	1
13	LOWER LEVER	1	1	1
14	LEVER PIVOT PIN O4 X 55 LG	1	1	1
15	PLUNGER (BUTTON TYPE)		2	4
16	BUTTON (RED)		1	1
17	BUTTON (GREEN)		1	1
18	BUTTON (BLACK)			1
19	BUTTON (WHITE)			1
23	M6 X 100 LG HEX HD BOLT			2
24	M6 X 8 LG SKT HD FULL DOG GRUB SCREW	1	1	1
27	M6 X 60 LG HEX HD BOLT		2	

When Replacement Parts Are Needed, Order Only Yale® Factory Engineered Parts

TYPE F11: BASIC 1/4"
TYPE F12: BASIC 1/2"
TYPE F17: BASIC 1"

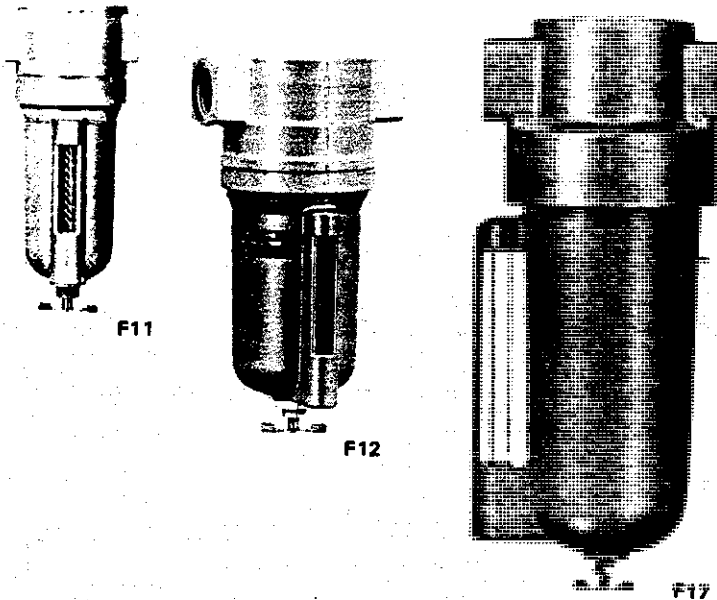

DESIGNER SERIES AIR FILTERS

- FOR COMPRESSED AIR SERVICE
- MANUAL OR AUTOMATIC DRAIN
- 1/4" THRU 1-1/2" PORTS

ORDER TABLE

Models listed include 50-micron element and automatic drain.

TYPE	PORT THREADS PTF	METAL BOWL WITH SIGHT GLASS	POLYCARBONATE BOWL WITH GUARD
F11	1/4" 3/8"	F11-200-A3DA F11-300-A3DA	F11-200-A3PA F11-300-A3PA
F12	1/4" 3/8" 1/2" 3/4"	F12-200-A3DA F12-300-A3DA F12-400-A3DA F12-600-A3DA	F12-200-A3PA F12-300-A3PA F12-400-A3PA F12-600-A3PA
F17	3/4" 1" 1-1/4" 1-1/2"	F17-600-A3DA F17-800-A3DA F17-A00-A3DA F17-800-A3DA	Not Available

Options:

- For manual drain, use "M" in 7th position (FXX-XXX-MXXX).
- For 5-micron element, use "1" in 8th position (FXX-XXX-X1XX).
- For 25-micron element, use "2" in 8th position (FXX-XXX-X2XX).
- For 75-micron element, use "4" in 8th position (FXX-XXX-X4XX).
- For metal bowl without sight glass, use "M" in 9th position (FXX-XXX-XXMX).
- For polycarbonate bowl without guard, use "T" in 9th position (FXX-XXX-XXTX). Not available on F17 filters.
- For short transparent bowl with manual drain and without guard, use "B" in 9th position. Available on F11 filters only (F11-XXX-XXBX).
- For ISO G ports, use "G" in 10th position (FXX-XXX-XXXG). Not available on F12 filters with 3/4" ports or F17 filters with 1-1/2" ports.

ACCESSORIES

	F11	F12	F17	
			3/4 & 1" PORTS	1-1/4" & 1-1/2" PORTS
Mounting Bracket	5203-02	5532-04	6212-50	6212-51
Bowl Guard	5176-02	5270-50	-	-

APPLICATION

Designer Series Filters are used in compressed air systems to remove most liquid and solid particles from the compressed air. They are designed for general application in compressed air systems where effective filtration and large flow capacity are required.

FEATURES

- Removes liquid and solid contaminants to protect air tools and other equipment.
- Screw-on bowl reduces maintenance time.
- Cleanable depth-type element has extra large surface area for long service life.
- Can be disassembled for cleaning without the use of tools and without removal from the air line.
- Choice of automatic or manual drain. Use automatic drain models if filter will be installed in an inaccessible area and when large quantities of water are present. Automatic drain operates when liquid accumulates above a certain level. Manual drain is a simple petcock.

REPAIR KITS

	F11	F12	F17
O-rings and Gaskets	3163-01	3019-09	5578-05
Element			
5-micron	3161-13	2992-18	5311-01
25-micron	3161-14	2992-19	5311-02
50-micron	3161-15	2992-20	5311-03
75-micron	5361-01	3793-01	5656-01
Liquid Level Sight Glass	2273-13	2273-08	2273-15

NORGREN®



OPERATION

A filter is used in a compressed air system to remove most liquid and solid particles from the compressed air. Air entering the filter is guided into a swirling pattern by the louvers (1). Coarse solid particles and liquids are forced to the bowl wall by centrifugal force and drop to the bottom. Baffle (2) creates a quiet zone at the bottom of the bowl and prevents air turbulence from picking up liquids and returning them to the air stream. The air then passes thru the filter element (3) where most finer solid particles are retained.

A drain (manual or automatic) is provided to drain accumulated liquid. The liquid level must be maintained below baffle (2) or liquid will be carried downstream. The manual drain is a simple petcock at the bottom of the bowl. The automatic drain (4 and 5) is a float operated mechanism at the bottom of the bowl which automatically expels any liquid that accumulates above a certain level. An over-accumulation of liquid in the bottom of the bowl causes float (4) to rise. This admits bowl pressure into the drain mechanism (5), opening a bleed valve and allowing excess liquid to be expelled under pressure. When the liquid level drops sufficiently, the float drops and draining stops. A screen (6) traps large particles which would not pass thru the drain mechanism. The automatic drain is normally open when the filter is not pressurized and any liquid that collects drains by gravity. The automatic drain closes when the bowl is pressurized to approximately 5 psig. Minimum operating pressure is 10 psig for the automatic drain.

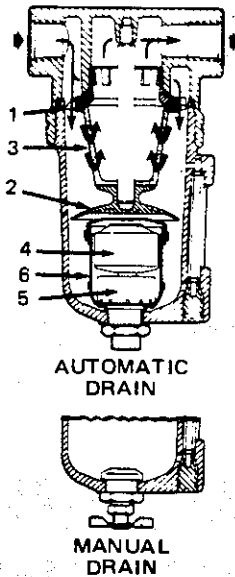

PERFORMANCE CHARACTERISTICS

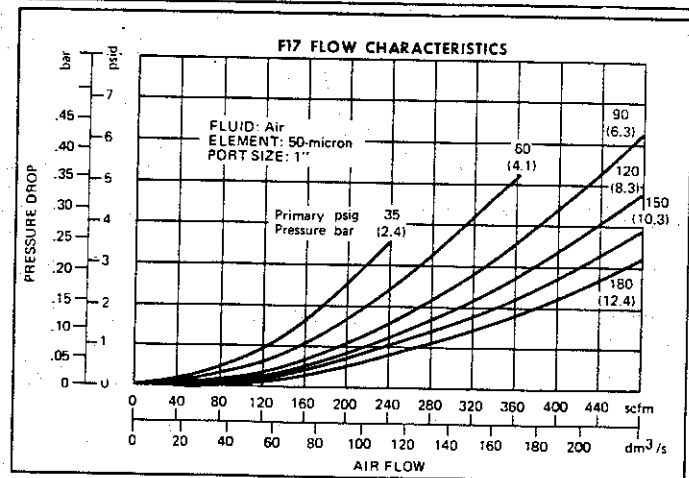
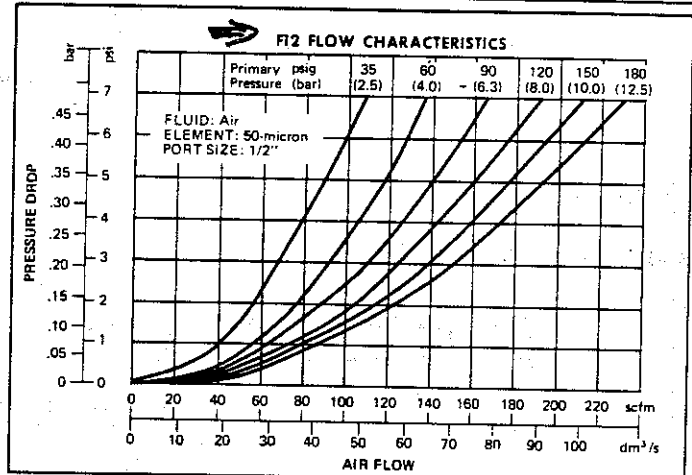
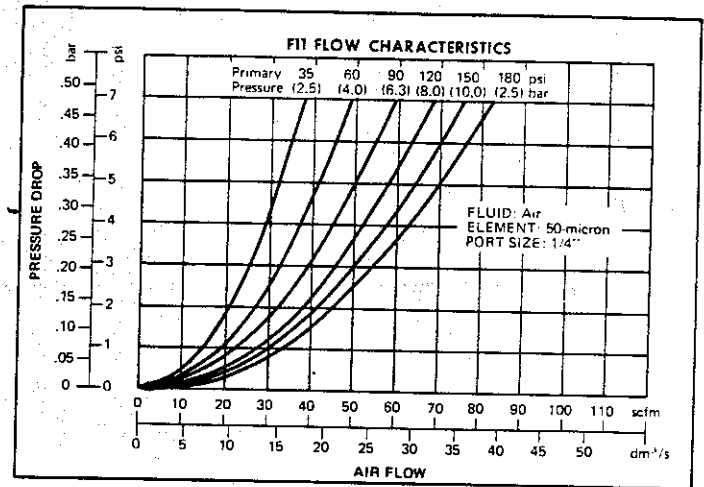

SPECIFICATIONS

MAXIMUM RATED OPERATING CONDITIONS -

Polycarbonate (Transparent) Bowl: 150 psig (10.3 bar); 125°F (52°C)

Metal Bowl: 250 psig (17.2 bar); 175°F (79°C)

FLUID: Compressed Air

PORT SIZES -

Type F11: 1/4", 3/8" PTF (G 1/4, G 3/8 ISO optional)

Type F12: 1/4", 3/8", 1/2" or 3/4" PTF (G 1/4, G 3/8 or G 1/2 ISO optional)

Type F17: 3/4", 1", 1-1/4" or 1-1/2" PTF (G 3/4, G 1 or G 1-1/4 ISO optional)

DRAIN: Automatic with 1/8" NPTF connection or manual

FILTER ELEMENT: 50-micron (5, 25 or 75-micron optional)

BOWL: Metal with sight glass (Metal without sight glass and polycarbonate are optional. The F17 is not available with polycarbonate bowl.)

MATERIALS OF CONSTRUCTION -

Body: Aluminum or Zinc on F11 and F12; Aluminum on F17

Bowl -

Transparent: Polycarbonate Plastic

Metal: Aluminum or Zinc on F11 and F12; Aluminum on F17

Sight Glass: Pyrex

Elastomers: Neoprene and Buna-N

Element -

5, 25, 50-micron -

Type F11 and F12: Porous Polypropylene (Plastic)

Type F17: Sintered Bronze

75-micron: Stainless Steel Screen

NOTE

These filters will remove most liquid and solid particles from the compressed air. Water vapor, however, will pass through the filters and could condense into liquid form downstream. Install an air dryer if water condensation will have a detrimental effect on the downstream application.

WARNING

THESE UNITS ARE INTENDED FOR USE IN INDUSTRIAL COMPRESSED AIR SYSTEMS ONLY. THEY MUST NOT BE USED WHERE PRESSURE OR TEMPERATURE MAY EXCEED MAXIMUM RATED OPERATING CONDITIONS. SEE SPECIFICATIONS.

THE POLYCARBONATE PLASTIC BOWLS USED ON THESE UNITS CAN BE DAMAGED AND POSSIBLY BURST IF EXPOSED TO SUCH SUBSTANCES AS CERTAIN SOLVENTS, STRONG ALKALIES, COMPRESSOR OILS CONTAINING ESTER-BASED ADDITIVES OR SYNTHETIC OILS. FUMES OF THESE SUBSTANCES IN CONTACT WITH THE POLYCARBONATE BOWL, EXTERNALLY OR INTERNALLY, CAN ALSO RESULT IN DAMAGE. CLEAN WITH WARM WATER ONLY.

USE METAL BOWL IN APPLICATIONS WHERE A PLASTIC BOWL MIGHT BE EXPOSED TO SUBSTANCES THAT ARE INCOMPATIBLE WITH POLYCARBONATE.

BEFORE USING WITH FLUIDS OTHER THAN AIR, FOR NON-INDUSTRIAL APPLICATIONS, OR FOR LIFE SUPPORT SYSTEMS CONSULT C. A. NORNGREN CO.

Replaces NC-222, NC-223, NC-226, NC-227

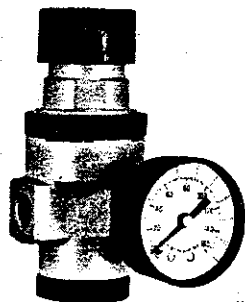

TYPE R11

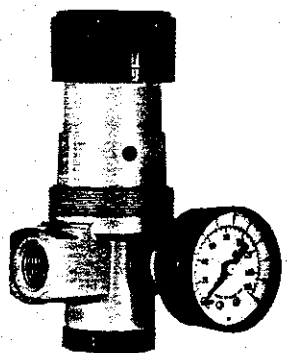

TYPE R12

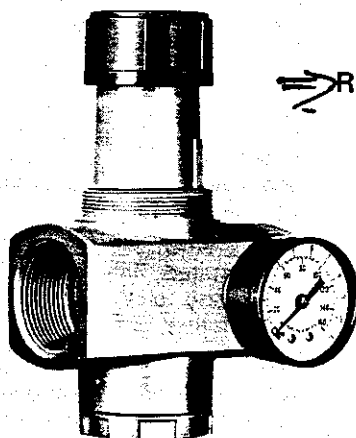

TYPE R17

→ TYPES R01 (T-HANDLE ADJUSTMENT) BASIC 1/4"
R11 (KNOB ADJUSTMENT) BASIC 1/4"
R12 (T-HANDLE OR KNOB ADJUSTMENT) BASIC 1/2"
R17 (T-HANDLE OR KNOB ADJUSTMENT) BASIC 1"

DESIGNER SERIES PRESSURE REGULATORS

- FOR COMPRESSED AIR SERVICE
- DIAPHRAGM TYPE
- RELIEVING OR NONRELIEVING
- 1/4" THRU 1-1/2" PORTS

FEATURES

- Easy hand adjustment under any pressure range.
- Nonrising adjustment knob has integral locking device which can be made tamper-resistant with addition of optional seal wire. T-handle adjustment with locknut also available.
- Wall mounting bracket and panel mount nut available.
- Accurate and quick response to flow demands and line pressure changes.
- Balanced valve design minimizes effect of variations in primary pressure on secondary pressure.
- Relieving or nonrelieving models. With relieving models, outlet pressure can be reduced even though the system is dead-ended.
- Easily disassembled for servicing without removal from air line.

WARNING

THESE REGULATORS ARE INTENDED FOR USE IN INDUSTRIAL COMPRESSED AIR SYSTEMS ONLY. DO NOT USE THESE REGULATORS WHERE PRESSURE OR TEMPERATURE CAN EXCEED RATED OPERATING CONDITIONS. SEE SPECIFICATIONS.

IF OUTLET PRESSURE IN EXCESS OF THE REGULATOR PRESSURE SETTING COULD CAUSE DOWNSTREAM EQUIPMENT TO RUPTURE OR MALFUNCTION, INSTALL A PRESSURE RELIEF DEVICE DOWNSTREAM OF THE REGULATOR. THE RELIEF PRESSURE AND FLOW CAPACITY OF THE RELIEF DEVICE MUST SATISFY SYSTEM REQUIREMENTS.

THE ACCURACY OF THE INDICATION OF PRESSURE GAUGES CAN CHANGE, BOTH DURING SHIPMENT (DESPITE CARE IN PACKAGING) AND DURING THE SERVICE LIFE. IF A PRESSURE GAUGE IS TO BE USED WITH THESE PRODUCTS AND IF INACCURATE INDICATIONS MAY BE HAZARDOUS TO PERSONNEL OR PROPERTY, THE GAUGE SHOULD BE CALIBRATED BEFORE INITIAL INSTALLATION AND AT REGULAR INTERVALS DURING USE. FOR GAUGE STANDARDS REFER TO ANSI B40.1-1974.

BEFORE USING WITH FLUIDS OTHER THAN AIR, FOR NON-INDUSTRIAL APPLICATIONS, OR FOR LIFE SUPPORT SYSTEMS CONSULT C. A. NORGREN CO.

SPECIFICATIONS

RATED OPERATING CONDITIONS —

INLET PRESSURE: 300 psig (20.7 bar) maximum
TEMPERATURE: 0° to 175°F (-18° to 79°C) with dew-point less than air temperature below 35°F (2°C).

FLUID: Compressed air

MAIN PORTS —

STANDARD —

R01 & R11: 1/4", 3/8" PTF
R12: 1/2", 3/4" PTF
R17: 3/4", 1", 1-1/4", 1-1/2" PTF

OPTIONAL —

R01 & R11: G 1/4, G 3/8 ISO
R12: G 1/2 ISO
R17: G 3/4, G 1, G1-1/4 ISO

GAUGE PORTS —

STANDARD: 1/4" PTF
OPTIONAL: G 1/4 ISO

TYPE —

STANDARD: Relieving diaphragm
OPTIONAL: Nonrelieving diaphragm

OUTLET PRESSURE ADJUSTMENT RANGES* —

STANDARD: 5 TO 125 psig (.3 TO 8.6 bar)
OPTIONAL: 5 TO 50 psig (.3 TO 3.5 bar)
OPTIONAL: 15 TO 250 psig (1.0 TO 17.2 bar)

MATERIALS OF CONSTRUCTION —

Body —

Type R01, R11, R12 Aluminum or Zinc
Type R17 Aluminum

Bonnet Aluminum or Zinc

Bottom Plug —

Type R01, R11, R12 Nylon
Type R17 Aluminum or Zinc

Valve Assembly —

Type R01, R11 Brass
Type R12 Brass & Acetal Resin
Type R17 Aluminum & Nylon

Elastomers Buna-N

*Outlet pressure adjustment ranges are not minimum or maximum outlet pressure limits. Regulators can be adjusted to zero psig outlet pressure and, generally, to pressures in excess of those specified. The use of these regulators to control pressures outside of the specified ranges is not recommended.

NORGREN
LITTLETON, COLORADO
©1983, C. A. NORGREN CO.



APPLICATION

Designer Series Regulators are used in compressed air systems to maintain a nearly constant outlet pressure despite changes in the inlet air pressure and changes in downstream flow requirements. They are designed for general application in compressed air systems where reliable, accurate pressure regulation and large flow capacity are required. Gauge ports are full-flow and can be used as auxiliary outlet ports.

ORDER TABLE

Standard models normally available from distributor stock.

RELIEVING TYPE: WITHOUT PRESSURE GAUGE; 5 TO 125 psig OUTLET PRESSURE ADJUSTMENT RANGE

MODEL NUMBER		PORT SIZE
Knob	T-Handle	
R11-200-RNLA	R01-200-RNLA	1/4"
R11-300-RNLA	R01-300-RNLA	3/8"
R12-400-RNLA	R12-401-RNLA	1/2"
R12-600-RNLA	R12-601-RNLA	3/4"
R17-600-RNLA	R17-601-RNLA	3/4" ←
R17-800-RNLA	R17-801-RNLA	1"
R17-A00-RNLA	R17-A01-RNLA	1-1/4"
R17-B00-RNLA	R17-B01-RNLA	1-1/2"

Options:

- For nonrelieving models, use "N" in 7th position (RXX-XXX-NXXX).
- For models with gauge, use "G" in 8th position (RXX-XXX-XGXX).
- For outlet pressure adjustment of 5 to 50 psig, use "E" in 9th position (RXX-XXX-XXEX).
- For outlet pressure adjustment of 15 to 250 psig, use "S" in 9th position (RXX-XXX-XXSX).
- For ISO G ports, use "G" in 10th position (RXX-XXX-XXXG). Not available on R12 units with 3/4" ports and R17 units with 1-1/2" ports.

ACCESSORIES

	Type R01 & R11	Type R12	Type R17
Wall mounting bracket	5203-05	5514-06*	5570-04*
Plastic panel mounting nut	Standard	5226-89	5226-89
Metal panel mounting nut	5191-01	5226-97	5226-97
Tamper resistant seal wire (knob adjustment only)	2117-01	2117-01	2117-01

*Includes 5226-89 plastic mounting nut.

REPAIR KITS

Includes diaphragm, valve, valve spring, and O-rings.

Regulator Type	Relieving	Non Relieving
R01 & R11	5298-02	5298-01
R12	5550-08	5550-07
R17**	5578-02	5578-01

OPERATION

A regulator is used in a compressed air system to maintain a nearly constant outlet pressure despite changes in the inlet air pressure and changes in downstream flow requirements.

Outlet pressure is controlled by the adjusting screw (1). Clockwise rotation increases and counterclockwise rotation decreases outlet pressure setting. When the adjustment (1) is rotated fully counterclockwise, no force is applied to the regulating spring (2), and the valve (6) is held closed by the valve spring (7). Clockwise rotation of the adjustment (1) compresses the regulating spring (2) which applies a downward force on top of the diaphragm (4). The diaphragm (4) and valve pin (5) move downward forcing valve (6) off its seat (10) which allows air to flow through the regulator to the downstream system.

Outlet pressure increases in the downstream system and sensing chamber (9) and applies an upward force on bottom of the diaphragm (4). The diaphragm (4), valve pin (5), and valve (6) move upward, compressing the regulating spring (2). Upward movement stops when the forces below the diaphragm balance the forces above the diaphragm. When there is no downstream flow demand, the balance of forces occurs with the valve (6) closed. When there is downstream flow demand, the balance of forces occurs when the valve opens sufficiently to compensate for demand, thus maintaining the desired outlet pressure.

RELIEVING TYPE REGULATORS. With relieving regulators, outlet pressure can be reduced even though the system is dead-ended. When the adjustment (1) is turned counterclockwise, the force on the regulating spring (2) is reduced, and air pressure in the sensing chamber (9) moves the diaphragm (4) upward. This upward movement opens the relief passage (8) in the diaphragm and allows air to escape from the outlet side of the regulator through the relief passage (8) and vent (3) to atmosphere. As the outlet pressure decreases to the reduced pressure setting, the diaphragm moves downward and closes the relief passage.

The diaphragm will likewise move upward in response to an increase in outlet pressure above the regulator setting, allowing air to escape to the atmosphere as described above. However, the flow capacity of the relief passage is limited, and depending upon the source of the overpressure condition, the outlet pressure might increase to a point significantly higher than the regulator setting. For this reason, the relief feature of a regulator must not be relied upon as an overpressure safety device. See WARNING note on first page.

NONRELIEVING TYPE REGULATORS. With nonrelieving regulators, outlet pressure can not be reduced if the system is dead-ended. The nonrelieving type regulator is identical to the relieving type with the exception of the diaphragm, which is not equipped with relief passage (8). This type of regulator will not vent the outlet air as described under "RELIEVING TYPE REGULATORS" and some other means of relieving the outlet air pressure must be provided.

** WARNING NOTE

In September, 1978 the R17 type regulator design was changed internally and, as a result, several parts are no longer interchangeable with models manufactured before that date. In the interest of safety, before attempting to replace any parts, contact your Norgren distributor for information.

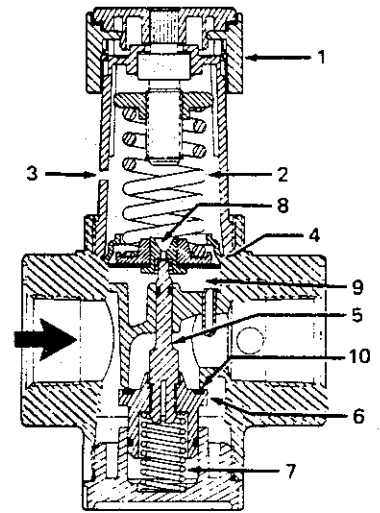

TYPE R17

TYPE L01
TYPE L12
TYPE L17

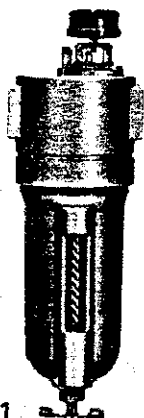

TYPE L01

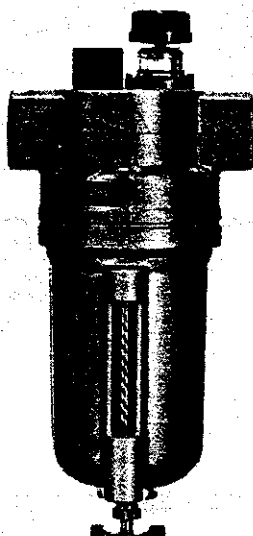

TYPE L12

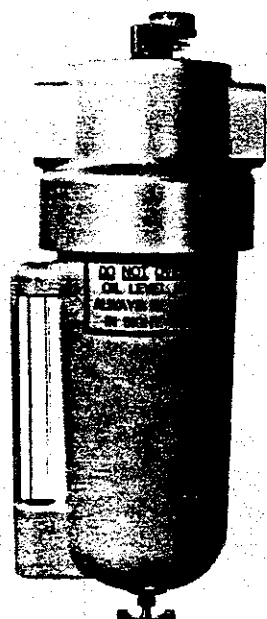

TYPE L17

APPLICATION

Norgren Oil-Fog Lubricators are used in industrial compressed air systems to lubricate air tools, cylinders, valves, air motors or other air driven devices that require lubrication. Individual Oil-Fog Lubricators should be provided for each device requiring lubrication. Micro-Fog Lubricators are recommended for systems containing complex piping and multiple points of lubrication. See NC-360.

Conventional Oil-Fog Lubricators must not be located downstream of frequently cycling directional control valves. Special Rapid-Cycle Oil-Fog Lubricators or Multi-Point Injection Lubricators are available for use under such conditions.

DESIGNER SERIES OIL-FOG LUBRICATORS

*FOR COMPRESSED AIR SERVICE
1/4" THRU 1-1/2" PORTS*

FEATURES

- Compact design.
- Flow sensor design provides a nearly constant oil/air ratio over a wide range of air flows.
- Simple, knob type oil-feed control integral with sight-feed dome permits fine adjustment of oil-feed rate to provide proper degree of lubrication at point of need.
- Final oil feed adjustment easily locked with integral push-pull locking ring on control knob. Optional seal wire can be installed to resist unauthorized adjustment.
- All around (360°) visibility of sight-feed dome simplifies installation and adjustment.
- Easily disassembled for servicing without removal from air line.
- Bracket mounting available.
- Reservoirs (except the two and five gallon sizes) can be refilled without shutting off air pressure.

HOW TO SELECT PROPER LUBRICATOR MODEL

1. Determine the port size and flow range required for your application, then refer to the Order Table on page 2 and select the appropriate lubricator. The lubricator selected should not exceed 5 psi pressure drop at the maximum flow condition of your system.
2. Determine your need for a transparent or metal bowl, standard or pyrex/aluminum sight-feed dome, etc. See Warning note on third page and Optional Equipment on second page.
3. Check the pressure and temperature requirements of your application against the Maximum Rated Operating Conditions given in the Order Table.

NORGREN®



ORDER TABLE AND SPECIFICATIONS

MODEL NUMBER		STD RSVR SIZE	PORT SIZE (PTF)	RECOMMENDED FLOW RANGE At 100 psig (6.9 bar) Inlet and 5 psid scfm (dm ³ /s)	MAXIMUM RATED OPERATING CONDITIONS	RECOMMENDED LUBRICANTS
Metal Reservoir With Sight Glass & Drain	Transparent Reservoir With Guard & Drain					
L01-200-OPDA L01-300-OPDA	L01-200-OPNA L01-300-OPNA	1/3-Pt.	1/4 3/8	1.5 to 20 (.7 to 9) 3 to 40 (1.4 to 19)	Transparent Reservoir – Pressure: 150 psig (10.3 bar) Temperature: 125°F (52°C) Metal Reservoir – Pressure: 250 psig (17.2 bar) Temperature: 175°F (79°C)	Use a misting type oil rated at 150 to 200 SSU at 100°F (38°C). The oil used must be compatible with materials of construction. Contact your lubricant supplier and the builder of the equipment to be lubricated to obtain lubricant recommendations.
L12-200-OPDA L12-300-OPDA L12-400-OPDA L12-600-OPDA	L12-200-OPNA L12-300-OPNA L12-400-OPNA L12-600-OPNA	1/2-Pt.	1/4 3/8 1/2 3/4	2 to 20 (1 to 9) 2.5 to 40 (1.2 to 19) 3.5 to 100 (1.7 to 47) 3.5 to 100 (1.7 to 47)		
L17-600-OPDA L17-800-OPDA L17-A00-OPDA L17-B00-OPDA	NOT AVAILABLE	1-Qt.	3/4 1 1-1/4 1-1/2	8 to 160 (3.8 to 75.5) 8 to 275 (3.8 to 129.8) 8 to 275 (3.8 to 129.8) 8 to 275 (3.8 to 129.8)		

OPTIONAL EQUIPMENT

OPTION	USED ON	HOW ORDERED	
Reservoir Options Standard size metal without sight glass, with drain Standard size transparent with guard, without drain Standard size transparent without guard, with drain Standard size transparent without guard, with drain 3-oz. transparent with drain, without guard 1-qt. metal with drain and sight glass 2-qt. metal with drain and sight glass 2-gal. metal with drain and sight glass* 5-gal. metal with drain and sight glass*	L01, L12, L17 L01, L12 L01 L12 L01 L12 L12, L17 L12, L17 L12, L17	Use the letter listed below in the 9th position of the model number (LXX-XXX-XX_X). M P C L B G H J K	
ISO G Threads (Not available on L12 models with 3/4" ports and L17 models with 1-1/2" ports)	L01, L12, L17	Use "G" in 10th position of model number (LXX-XXX-XXXG).	
		FACTORY INSTALLED (Specify in addition to the model number)	FIELD INSTALLATION
Quick Fill Cap	L01 L12, L17	18-011-007 18-011-020	18-011-008 18-011-021
Low Oil Level Switch	L12 (1-qt.) L12 (2-qt.) L12 (2-gal.) L12 (5-gal.) L17 (2-qt.) L17 (2-gal.) L17 (5-gal.)	18-023-601 18-023-603 18-023-605 18-023-607 18-023-611 18-023-613 18-023-615	18-023-602 18-023-604 18-023-606 18-023-608 18-023-612 18-023-614 18-023-616
High/Low Oil Level Switch	L12 (2-gal.) L12 (5-gal.) L17 (2-gal.) L17 (5-gal.)	18-023-651 18-023-653 18-023-655 18-023-657	18-023-652 18-023-654 18-023-656 18-023-658
Remote Fill Device	L01 (1/3-pt.) L12 (1/2-pt.)	Specify "WITH REMOTE FILL"	See NC-809
Pyrex/Aluminum Sight Feed Dome	L01 L12, L17	5605-54 5605-61**	5605-50 5605-60**
Aluminum Fill Plug	L01 L12, L17	Standard 5301-02	1206-50 5301-50
Tamper Resistant Seal Wire	L01, L12, L17	2117-01†	
Mounting Bracket 1/2-pt., 1-qt., 2-qt. 1-qt., 2-qt. 1-qt., 2-qt.	L01 L12 L17 (3/4 & 1") L17 (1-1/4 & 1-1/2")	5203-02 5532-04 6212-50 6212-51	
Mounting Strap 2-gal. 5-gal.	L12, L17		18-001-056 18-001-039

*The 2 and 5-gallon steel reservoirs are ASME rated to Section VIII of the ASME Pressure Vessel Code.

**Includes 5301-50 aluminum fill plug.

†Fits standard sight feed dome only.

REPAIR KITS

L01 L12 L17

O-rings	5324-01	5771-01	5771-02
Sight Glass* (Std. Size Rsvrs)	2273-13	2273-08	2273-15
Sight Glass† (Std. Size Rsvrs)	2273-07	2273-06	2273-05
Sight Glass (Large Rsvrs)			
L12 (1 qt.)	—	2272-02	—
L12 & L17 (2 qt.)	—	2273-04	2273-04
L12 & L17 (2 & 5 gal.)	—	2274-01	2274-01
Pyrex Aluminum Sight Feed Dome	5738-01	5738-01	5738-01

*Used on current models.

†Used on early models that used screws to attach the sight glass to the reservoir.

POWERED HOIST INSPECTION CHECK LIST

SEE PREVENTIVE MAINTENANCE SECTION OF INSTRUCTION MANUAL FOR DETAILS.

CHECK ONLY COMPONENTS APPLICABLE FOR SPECIFIC EQUIPMENT AND INSPECTION TYPE.

HOIST MODEL _____

HOIST S/N _____

HOOKS	YES	NO	CABLE	YES	NO	CHAINS	YES	NO
HARDWARE LOOSE	<input type="checkbox"/>	<input type="checkbox"/>	BROKEN WIRES AT ENDS	<input type="checkbox"/>	<input type="checkbox"/>	BINDING	<input type="checkbox"/>	<input type="checkbox"/>
CRACKS	<input type="checkbox"/>	<input type="checkbox"/>	BROKEN WIRES EXCESSIVE	<input type="checkbox"/>	<input type="checkbox"/>	CRACKED	<input type="checkbox"/>	<input type="checkbox"/>
EXCESSIVE WEAR	<input type="checkbox"/>	<input type="checkbox"/>	EXCESSIVE WEAR	<input type="checkbox"/>	<input type="checkbox"/>	TWISTED	<input type="checkbox"/>	<input type="checkbox"/>
BENT	<input type="checkbox"/>	<input type="checkbox"/>	KINKED OR DISTORTED	<input type="checkbox"/>	<input type="checkbox"/>	DISTORTED	<input type="checkbox"/>	<input type="checkbox"/>
SPREADING	<input type="checkbox"/>	<input type="checkbox"/>	CORROSION	<input type="checkbox"/>	<input type="checkbox"/>	CORRODED	<input type="checkbox"/>	<input type="checkbox"/>
FREELY ROTATE	<input type="checkbox"/>	<input type="checkbox"/>	HEAT DAMAGED	<input type="checkbox"/>	<input type="checkbox"/>	EXCESSIVE WEAR	<input type="checkbox"/>	<input type="checkbox"/>
LATCH DAMAGED	<input type="checkbox"/>	<input type="checkbox"/>				WORN CHAIN GUIDES	<input type="checkbox"/>	<input type="checkbox"/>
						POCKET WHEELS WORN	<input type="checkbox"/>	<input type="checkbox"/>
BRAKES	YES	NO	WIRING	YES	NO	DRUM & SHEAVES	YES	NO
MOTOR BRAKE WORN OR NOT OPERATING	<input type="checkbox"/>	<input type="checkbox"/>	LOOSE CONNECTIONS	<input type="checkbox"/>	<input type="checkbox"/>	WORN EXCESSIVELY	<input type="checkbox"/>	<input type="checkbox"/>
EXCESSIVE LOADBRAKE DRIFT OR BLACKLASH	<input type="checkbox"/>	<input type="checkbox"/>	FRAYED	<input type="checkbox"/>	<input type="checkbox"/>	CRACKED OR SCORED	<input type="checkbox"/>	<input type="checkbox"/>
EXCESSIVE DISC WEAR	<input type="checkbox"/>	<input type="checkbox"/>	DAMAGED	<input type="checkbox"/>	<input type="checkbox"/>			
			PROPER GROUNDING	<input type="checkbox"/>	<input type="checkbox"/>			
LIMIT SWITCHES	YES	NO	LOAD LIMITING DEVICE	YES	NO	COLLECTORS	YES	NO
OPERATING PROPERLY	<input type="checkbox"/>	<input type="checkbox"/>	OPERATING PROPERLY	<input type="checkbox"/>	<input type="checkbox"/>	BINDING	<input type="checkbox"/>	<input type="checkbox"/>
						EXCESSIVE WEAR	<input type="checkbox"/>	<input type="checkbox"/>
HOUSING	YES	NO	OPERATION CONTROLS	YES	NO	LUBRICATION	YES	NO
DISTORTED	<input type="checkbox"/>	<input type="checkbox"/>	CONTACTOR PITTING	<input type="checkbox"/>	<input type="checkbox"/>	ALL POINTS LUBRICATED AS GIVEN IN LUB CHART	<input type="checkbox"/>	<input type="checkbox"/>
CRACKS	<input type="checkbox"/>	<input type="checkbox"/>	OPERATING PROPERLY	<input type="checkbox"/>	<input type="checkbox"/>	OIL DARK OR LOW	<input type="checkbox"/>	<input type="checkbox"/>
LOOSE HARDWARE	<input type="checkbox"/>	<input type="checkbox"/>	DAMAGED PUSH BUTTON	<input type="checkbox"/>	<input type="checkbox"/>	OIL LEAKS	<input type="checkbox"/>	<input type="checkbox"/>
BEARING NOISE	<input type="checkbox"/>	<input type="checkbox"/>	HOUSING	<input type="checkbox"/>	<input type="checkbox"/>			
SUPPORTING STRUCTURE	YES	NO	AIR SYSTEM	YES	NO	WARNING LABELS	YES	NO
CONTINUED ABILITY TO SUPPORT IMPOSED LOADS	<input type="checkbox"/>	<input type="checkbox"/>	LEAKING	<input type="checkbox"/>	<input type="checkbox"/>	MISSING	<input type="checkbox"/>	<input type="checkbox"/>
WORN OR DISTORTED TROLLEY PARTS	<input type="checkbox"/>	<input type="checkbox"/>	LOOSE CONNECTIONS	<input type="checkbox"/>	<input type="checkbox"/>	ILLEGIBLE	<input type="checkbox"/>	<input type="checkbox"/>
			BROKEN CONTROL PENDANT	<input type="checkbox"/>	<input type="checkbox"/>			

NOTE: IF ANY () IS CHECKED DO NOT OPERATE THE HOIST UNTIL REPAIRS HAVE BEEN MADE.

REMARKS AND REPAIRS MADE _____

SIGNATURE _____

DATE _____

CLOCK NUMBER _____

POWERED HOIST INSPECTION CHECK LIST

SEE PREVENTIVE MAINTENANCE SECTION OF INSTRUCTION MANUAL FOR DETAILS.

CHECK ONLY COMPONENTS APPLICABLE FOR SPECIFIC EQUIPMENT AND INSPECTION TYPE.

HOIST MODEL _____

HOIST S/N _____

HOOKS	YES	NO	CABLE	YES	NO	CHAINS	YES	NO
HARDWARE LOOSE	<input type="checkbox"/>	<input type="checkbox"/>	BROKEN WIRES AT ENDS	<input type="checkbox"/>	<input type="checkbox"/>	BINDING	<input type="checkbox"/>	<input type="checkbox"/>
CRACKS	<input type="checkbox"/>	<input type="checkbox"/>	BROKEN WIRES EXCESSIVE	<input type="checkbox"/>	<input type="checkbox"/>	CRACKED	<input type="checkbox"/>	<input type="checkbox"/>
EXCESSIVE WEAR	<input type="checkbox"/>	<input type="checkbox"/>	EXCESSIVE WEAR	<input type="checkbox"/>	<input type="checkbox"/>	TWISTED	<input type="checkbox"/>	<input type="checkbox"/>
BENT	<input type="checkbox"/>	<input type="checkbox"/>	KINKED OR DISTORTED	<input type="checkbox"/>	<input type="checkbox"/>	DISTORTED	<input type="checkbox"/>	<input type="checkbox"/>
SPREADING	<input type="checkbox"/>	<input type="checkbox"/>	CORROSION	<input type="checkbox"/>	<input type="checkbox"/>	CORRODED	<input type="checkbox"/>	<input type="checkbox"/>
FREELY ROTATE	<input type="checkbox"/>	<input type="checkbox"/>	HEAT DAMAGED	<input type="checkbox"/>	<input type="checkbox"/>	EXCESSIVE WEAR	<input type="checkbox"/>	<input type="checkbox"/>
LATCH DAMAGED	<input type="checkbox"/>	<input type="checkbox"/>				WORN CHAIN GUIDES	<input type="checkbox"/>	<input type="checkbox"/>
						POCKET WHEELS WORN	<input type="checkbox"/>	<input type="checkbox"/>
BRAKES	YES	NO	WIRING	YES	NO	DRUM & SHEAVES	YES	NO
MOTOR BRAKE WORN OR NOT OPERATING	<input type="checkbox"/>	<input type="checkbox"/>	LOOSE CONNECTIONS	<input type="checkbox"/>	<input type="checkbox"/>	WORN EXCESSIVELY	<input type="checkbox"/>	<input type="checkbox"/>
EXCESSIVE LOADBRAKE DRIFT OR BLACKLASH	<input type="checkbox"/>	<input type="checkbox"/>	FRAYED	<input type="checkbox"/>	<input type="checkbox"/>	CRACKED OR SCORED	<input type="checkbox"/>	<input type="checkbox"/>
EXCESSIVE DISC WEAR	<input type="checkbox"/>	<input type="checkbox"/>	DAMAGED	<input type="checkbox"/>	<input type="checkbox"/>			
			PROPER GROUNDING	<input type="checkbox"/>	<input type="checkbox"/>			
LIMIT SWITCHES	YES	NO	LOAD LIMITING DEVICE	YES	NO	COLLECTORS	YES	NO
OPERATING PROPERLY	<input type="checkbox"/>	<input type="checkbox"/>	OPERATING PROPERLY	<input type="checkbox"/>	<input type="checkbox"/>	BINDING	<input type="checkbox"/>	<input type="checkbox"/>
						EXCESSIVE WEAR	<input type="checkbox"/>	<input type="checkbox"/>
HOUSING	YES	NO	OPERATION CONTROLS	YES	NO	LUBRICATION	YES	NO
DISTORTED	<input type="checkbox"/>	<input type="checkbox"/>	CONTACTOR PITTING	<input type="checkbox"/>	<input type="checkbox"/>	ALL POINTS LUBRICATED AS GIVEN IN LUB CHART	<input type="checkbox"/>	<input type="checkbox"/>
CRACKS	<input type="checkbox"/>	<input type="checkbox"/>	OPERATING PROPERLY	<input type="checkbox"/>	<input type="checkbox"/>	OIL DARK OR LOW	<input type="checkbox"/>	<input type="checkbox"/>
LOOSE HARDWARE	<input type="checkbox"/>	<input type="checkbox"/>	DAMAGED PUSH BUTTON	<input type="checkbox"/>	<input type="checkbox"/>	OIL LEAKS	<input type="checkbox"/>	<input type="checkbox"/>
BEARING NOISE	<input type="checkbox"/>	<input type="checkbox"/>	HOUSING	<input type="checkbox"/>	<input type="checkbox"/>			
SUPPORTING STRUCTURE	YES	NO	AIR SYSTEM	YES	NO	WARNING LABELS	YES	NO
CONTINUED ABILITY TO SUPPORT IMPOSED LOADS	<input type="checkbox"/>	<input type="checkbox"/>	LEAKING	<input type="checkbox"/>	<input type="checkbox"/>	MISSING	<input type="checkbox"/>	<input type="checkbox"/>
WORN OR DISTORTED TROLLEY PARTS	<input type="checkbox"/>	<input type="checkbox"/>	LOOSE CONNECTIONS	<input type="checkbox"/>	<input type="checkbox"/>	ILLEGIBLE	<input type="checkbox"/>	<input type="checkbox"/>
			BROKEN CONTROL PENDANT	<input type="checkbox"/>	<input type="checkbox"/>			

NOTE: IF ANY () IS CHECKED DO NOT OPERATE THE HOIST UNTIL REPAIRS HAVE BEEN MADE.

REMARKS AND REPAIRS MADE _____

SIGNATURE _____ DATE _____ CLOCK NUMBER _____

Yale®

HOISTS

WARRANTY

Every hoist is thoroughly inspected and tested prior to shipment from the factory. Should any problems develop, return the complete hoist prepaid to your nearest Yale Hoists Authorized Warranty Repair Station.

This warranty does not apply where: (1) deterioration is caused by normal wear, abuse, improper or inadequate power supply, eccentric or side loading, overloading, chemical or abrasive actions, improper maintenance or excessive heat; (2) problems resulted from repairs, modifications or

alterations made by persons other than factory or Yale Hoists personnel; (3) the hoist has been abused or damaged as a result of an accident; (4) repair parts or accessories other than those supplied by Yale Hoists are used on the hoist. Equipment and accessories not of the seller's manufacture are warranted only to the extent that they are warranted by the manufacturer. EXCEPT AS STATED HEREIN, YALE HOISTS MAKES NO OTHER WARRANTIES, EXPRESS OR IMPLIED, INCLUDING WARRANTIES OF MERCHANTABILITY AND FITNESS FOR A PARTICULAR PURPOSE.

Improvements:

Yale Hoists is constantly striving to improve its product. Changes in design and improvements will be made whenever manufacturer believes the efficiency of the product will be improved without incurring any obligation to incorporate such improvements in any products which have been shipped or are in service.

Important Notice:

Use of chain, wire rope or replacement parts other than as supplied as original equipment on Yale hoists may lead to dangerous operation. Accordingly, Yale Hoists cannot be responsible in such cases and our warranty will be voided.

For more information, write Yale Hoists, Forrest City, Arkansas 72335.

For more information contact:
American Crane & Equipment Corp.
Authorized Distributor
Tel: 877-503-2972
Fax: 484-945-0430
sales@americancrane.com
www.americancrane.com

Yale® HOISTS
3105 N. Washington
P. O. Box 1000
Forrest City, Arkansas 72335
Customer Service (800) 999-6318
FAX (800) 766-0223