

SHAW-BOX®

AIR HOIST SUPPLEMENT TO 113533-72
(OPERATION, SERVICE & PARTS MANUAL
FOR SERIES 800 SHAW-BOX
WIRE ROPE ELECTRIC HOISTS)
(1/2 THRU 5 TON RATED LOADS)

SHAW-BOX Series 800 Wire Rope Air Hoists use the same mechanical parts as the Wire Rope Electric Hoists. The electric motor, controls and push button of the electric hoist are replaced by an air motor, control valve and pendant control assembly for the air hoist. A motor brake is also available as an option.

This supplement, which contains instructions and parts lists pertaining to the air motor, control valve and pendant control assembly (and brake if furnished), is to be used in conjunction with the relevant parts of 113533-72 to provide information on the Series 800 Wire Rope Air Hoists.

A pressure regulator valve, to maintain proper pressure, and a filter lubricator unit must be installed, near the hoist-between the air source and the air hose leading to the hoist.

The following table is meant as a guide only. Provide proper fittings to furnish required pressure and volume.

Never drive this hoist with combustible gas.

Note: When first running the motor some light oil should be injected into the inlet connection to ensure adequate lubrication until the airline lubricator is established.

MOTOR DATA

<u>Motor Size</u>	<u>Air Inlet Size</u>	<u>Air Consumption (cfm)</u>	<u>Lubricator Drops Per Minute*</u>
V6	3/4" NPT	110-125	5-6

*Double the lubrication drip rate if operation is intermittent.

One motor size is available.

The recommended operating air pressure is 90 psi **at the hoist**. If the air pressure source is far enough removed from the hoist to allow a drop in pressure, 90 psi (dynamic) at the hoist must be maintained when the hoist is running.

Maximum working air pressure is 100 psi.

INSTALLATION

1. Mounting Position.

The motor and other components are mounted as shown on the Air Hoist Assembly on Figure 1.

P.O. Box 769
Muskegon, MI 49443-0769

Phone: **800 742-9269**
Fax: **800 742-9270**

2. Recommended Lubricants for Normal Ambient Temperature (0-32 Degrees C).

Supplier	Air Line Lube
Shell	TELLUS 32
Exxon	FANOX N 33
Texaco	RANDO Oil HD 32
Mobil	ALMO 525
Generic	SAE 20

For extremes of ambient temperatures consult the oil manufacturers.

3. Air Inlet

The air is input to the RVC Control.: Valve. All motors are reversible.

4. Air Supply. Maximum Working Pressure 7 bar - 100 psi.

The air supply must be clean and free from moisture. An air line filter and mist lubricator must be incorporated in the air supply line located immediately before the motor. If the rated performance of the motor is to be obtained all valves and pipework must be of adequate size. Valves should be sited as close as possible to the motor.

5. Fitting

Mount motor in operating position. Before connecting to the air supply blow out air lines to remove any loose scale, debris or abrasive dust which may be present. Remove the red plastic dust caps.

The motor should not be allowed to race.

MAINTENANCE

6. Air Supply

The air filter should be drained regularly and examined for clogging of the element. The air line lubricator should be replenished as required and set to give the drip rate specified on page 1.

7. Motor

The motor is lubricated by the oil dripped into the air line.

8. Optional Brake

Check the brake after the first 30 days of service and regularly thereafter.

The brakes are adjusted by part numbers 13. The brakes are spring set and the springs are released by applied air pressure. Adjust as required.

9. Servicing

It is recommended that the air motor be taken to an authorized SHAWBOX repair station for repairs.

Lack of lubrication will lead to rapid wear, internal seizure, loss of power or excessive air leakage.

Faults in the air supply system may be due to failure to remove plastic protective dust caps, supply pipe line or valve too small, excessive back pressure due to small bore pipes when exhaust is piped away or clogged air line filter.

The following parts lists and drawings cover parts not included in 113533-72.

The numbers assigned to the parts of our various assemblies in our parts list are not the part numbers used in manufacturing the part. They are identification numbers, that when given with the model number, permit us to identify, select or manufacture and ship the correct part needed.

Schematics follow the parts list.

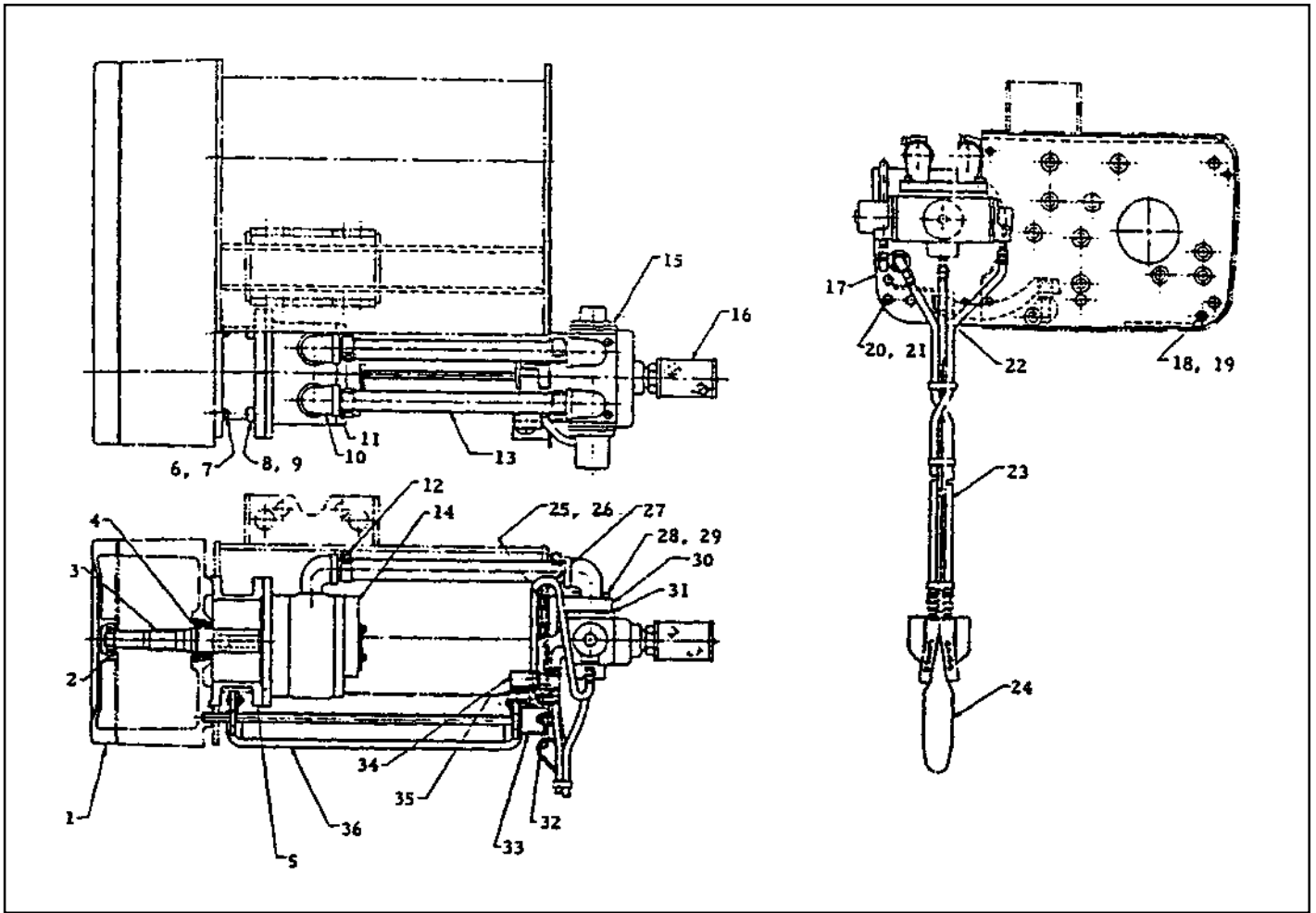

Figure 1. Air Hoist Assembly

Ref. No.	Part Number	Description	Qty. Req'd
1	800AH-101	Gear Case Cover	1
2	800AH-102	Bearing	1
3	800AH-103	Motor Shaft Extension	1
4	800AH-104	Retaining Ring	1
5	800AH-105	Motor Spacer	1
6	800AH-106	Hex Socket Head Cap Screw (#10-32 x 7/8)	4
7	800AH-107	Lockwasher (#10)	4
8	800AH-108	Hex Socket Head Cap Screw (3/8-16 x 1)	4
9	800AH-109	Lockwasher (3/8)	4
10	800AH-110	90° Elbow	4
11	800AH-111	Close Pipe Nipple	4
12	800AH-112	Hose Clamp	4
13		Hose	2
	800AH-113	5" Long	
	800AH-114	12" Long	
	800AH-115	18-1/8" Long	1
14	See Fig. 2	Air Motor Assembly	1
15	See Fig. 3	Control Valve	1
16	800AH-116	Muffler	1
17	800AH-117	Base Plate	1
18	800AH-118	Hex Socket Head Cap Screw (5/16-18 x 1/2)	4

Figure 1. Air Hoist Assembly (Continued)

Ref. No.	Part Number	Description	Qty. Req'd
19	800AH-119	Lockwasher (5/16)	4
20	800AH-120	Hex Head Bolt (1/4-20 x 5/8)	4
21	800AH-121	Self-locking Nut (1/4)	4
22	800AH-122	Spring Pin	1
23	See Fig. 4	Hose Assembly	1
	800AH-123	14' Lift	
	800AH-124	18' Lift	
	800AH-125	20' Lift	
	800AH-126	25' Lift	
	800AH-127	39' Lift	
	800AH-128	34' Lift	
	800AH-129	40' Lift	
	800AH-145	45' Lift	
	800AH-130	50' Lift	
24	See Fig. 4	Pendant Control Station	1
25	800AH-131	Hex Head Bolt (5/16-18 x 3/4)	4
26	800AH-132	Lockwasher (5/16)	4
27	800AH-133	Hose Assembly	1
28	800AH-134	Hex Socket Head Cap Screw (M6 x 25)	4
29	800AH-135	Lockwasher (1/4 Hi-Collar)	4
30	800AH-136	Manifold	1
31	800AH-137	Manifold Gasket	1
32	800AH-138	Mounting Bracket	1
33	800AH-139	Limit Lever Extension	1
34	800AH-140	Limit Valve	1
35	800AH-141	Lockwasher (3/4)	1
36		Limit Lever Assembly for Hoists:	1
	800AH-142	1 Ton w/ 18' & 25' Lifts and 2 Ton w/ 14' & 20' Lifts	
	800AH-143	1 Ton w/ 34' & 50' Lifts and 2 Ton w/ 25' & 40' Lifts	
	800AH-144	3 Ton w/ 30' Lift and 5 Ton w/ 20' Lift	
	800AH-146	3 Ton w/ 45' Lift and 5 Ton w/ 30' Lift	

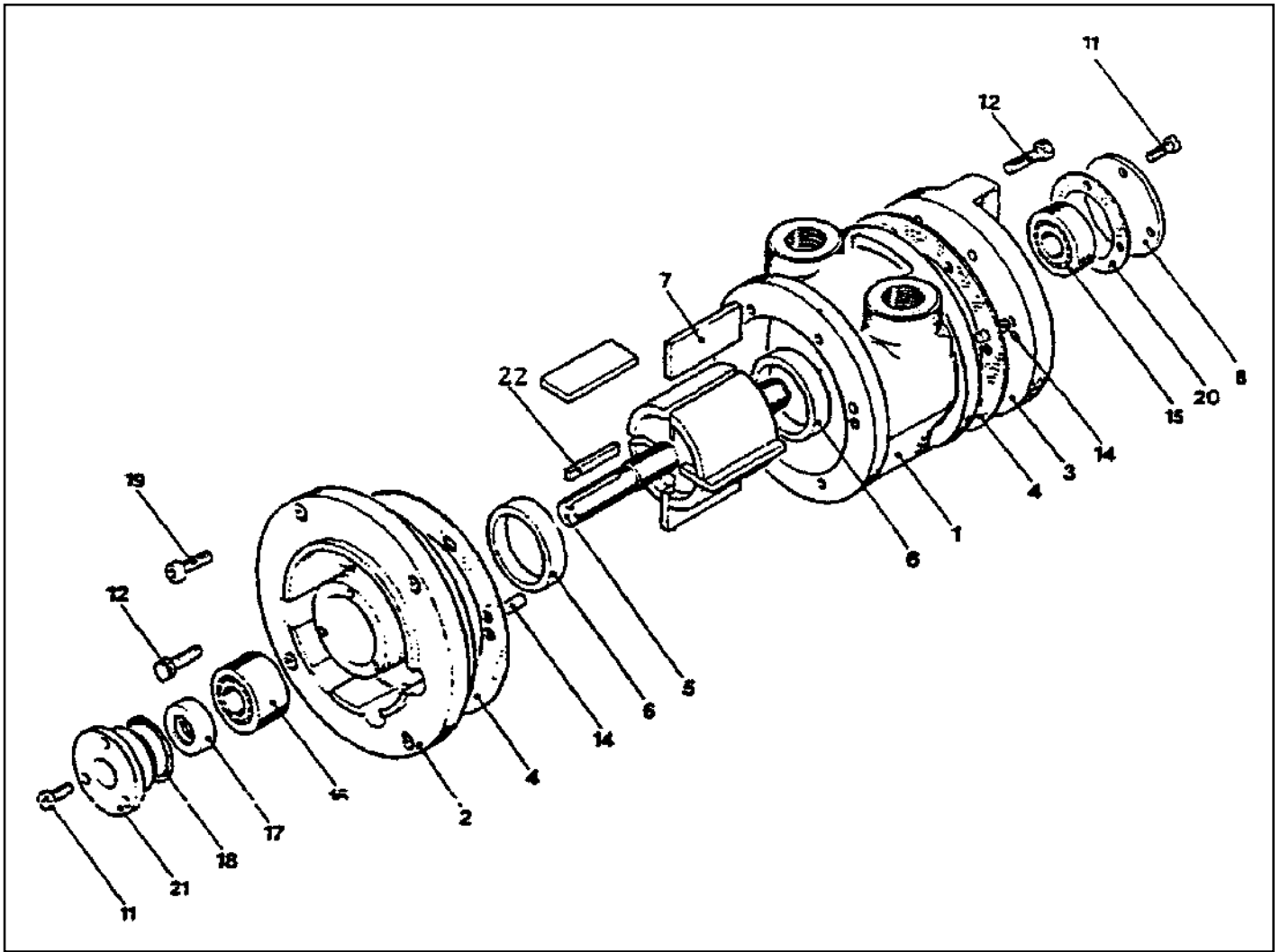

Figure 2. Air Motor Assembly

Ref. No.	Part Number	Description	Qty. Req'd
	800AH-201	Air Motor Assembly	1
1	800AH-202	Body	1
2	800AH-203	Front Plate	1
3	800AH-204	End Plate	1
4	800AH-205	Body Gasket	2
5	800AH-206	Rotor Shaft	1
6	800AH-207	Ejection Ring	2
7	800AH-208	Rotor Blade	4
8	800AH-209	Cover Plate	1
11	800AH-210	Screw (M5 x 12)	6
12	800AH-211	Hex Head Bolt (M6 x 20)	6
14	800AH-212	Dowel	4
15	800AH-213	Single Row Bearing	1
16	800AH-214	Double Row Bearing	1
17	800AH-215	Oil Seal	1
18	800AH-216	'O' Ring	1
19	800AH-217	Hex Socket Head Cap Screw (M6 x 16)	6
20	800AH-218	Gasket	1
21	800AH-219	Seal Housing	1

Service Kit Part Number 800AH-220 includes Ref. Nos. 4, 7, 17, 18 and 20

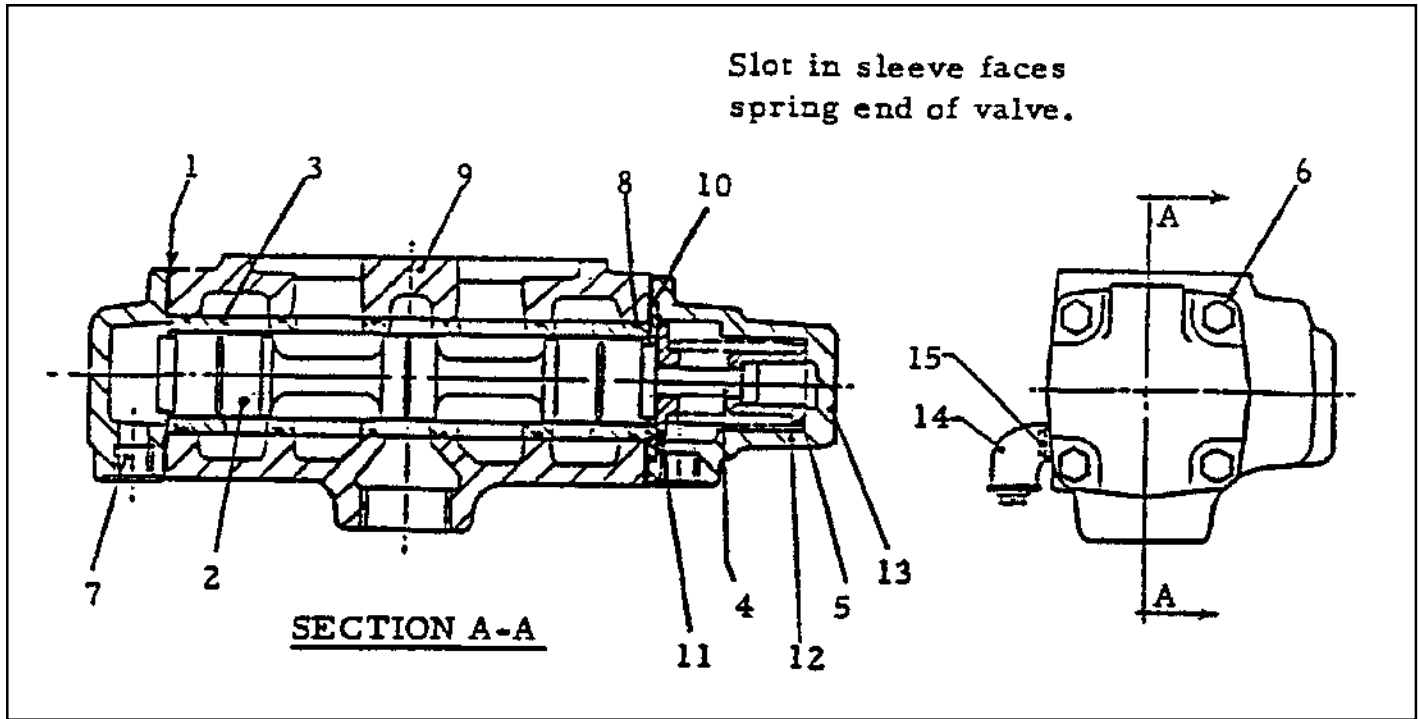

Figure 3. RVC Control Valve

Ref. No.	Part Number	Description	Qty. Req'd
	800AH-301	Control Valve	1
1	800AH-302	End Cap Gasket	2
2	800AH-303	Valve Spool	1
3	800AH-304	Valve Sleeve	1
4	800AH-305	Shoulder Screw	1
5	800AH-306	Shaft Guide	1
6	800AH-307	Hex Head Bolt	8
7	800AH-308	End Cap	1
8	800AH-309	'O' Ring	6
9	800AH-310	Valve Body	1
10	800AH-311	Spacer	1
11	800AH-312	Washer	1
12	800AH-313	Spring	1
13	800AH-314	End Cap	1
14	800AH-315	Elbow	1
15	800AH-316	Plug	3

Notes

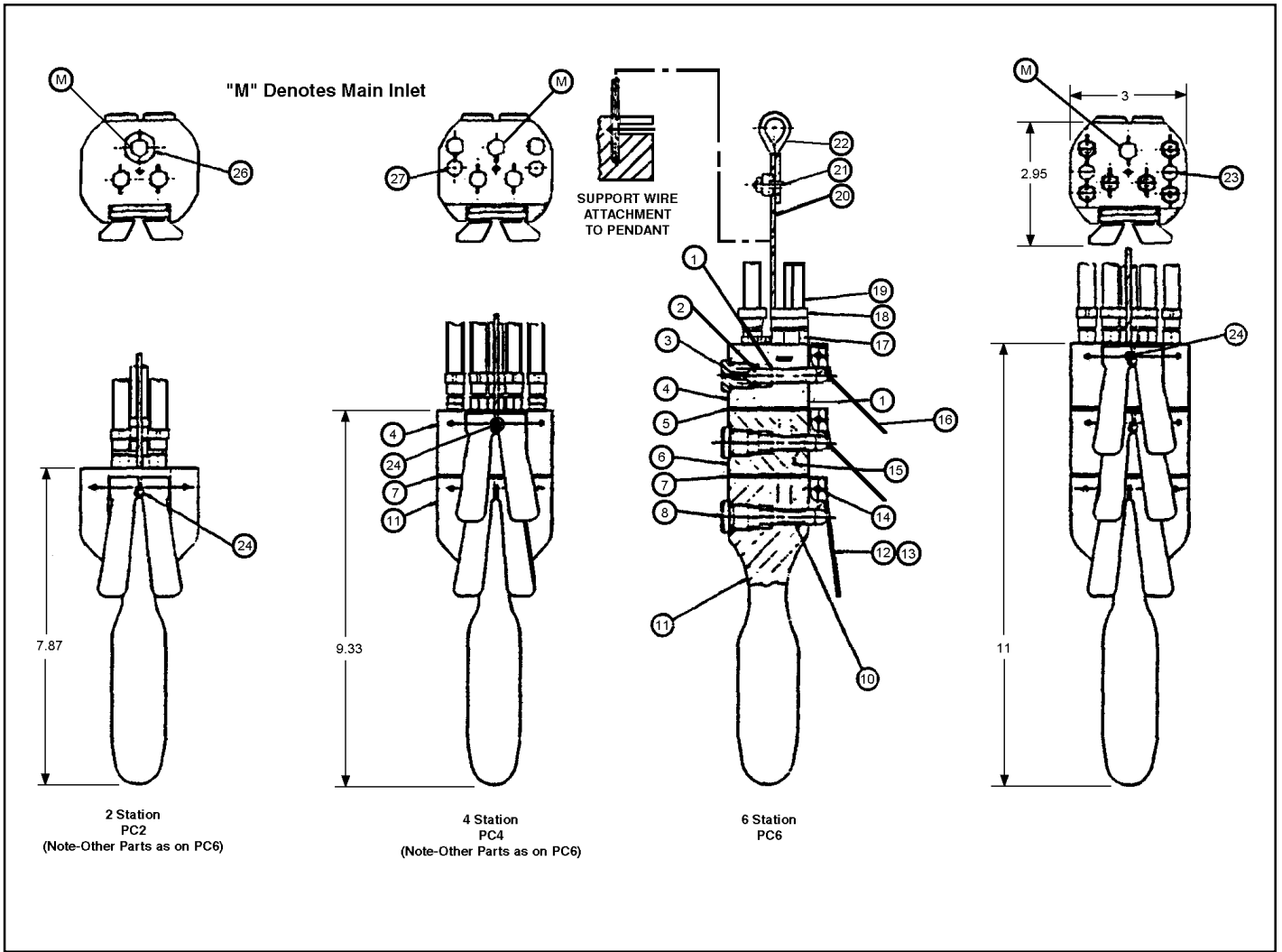

Figure 4. Pendant Control Assemblies PC2, PC4 & PC6

Ref. No.	Part Number	Description	Quantity Required		
			2 Station	4 Station	6 Station
		Pendant Control Station			
	800AH-401	2 Station	1	--	--
	800AH-402	4 Station	--	1	--
	800AH-403	6 Station	--	--	1
1	800AH-404	'O' Ring	2	6	10
2	800AH-405	'O' Ring	2	4	6
3	800AH-406	Compression Spring	2	4	6
4	800AH-407	Top Body	--	1	1
5	800AH-408	Gasket	--	--	1
6	800AH-409	Intermediate Body	--	--	1
7	800AH-410	Gasket	--	1	1
8	800AH-411	Valve Plug	2	4	6
10	800AH-412	Plunger	2	2	2
11	800AH-413	Handle	1	1	1
12	800AH-414	'Raise' Lever	1	1	1
13	800AH-415	'Lower' Lever	1	1	1
14	800AH-416	Lever Pivot Pin	1	1	1
15	800AH-417	Plunger	--	2	4

Figure 4. Pendant Control Assemblies PC2, PC4 & PC6 (Continued)

Ref. No.	Part Number	Description	Quantity Required		
			2 Station	4 Station	6 Station
16		Button			
	800AH-418	Trolley Left	--	1	1
	800AH-419	Trolley Right	--	1	1
	800AH-418	Trolley Left	--	--	1
	800AH-419	Trolley Right	--	--	1
23	800AH-422	Hex Head Bolt	--	--	2
24	800AH-423	Socket Head Full Dog Grub Screw	1	1	1
26	800AH-424	Reducing Bushing	1	--	--
27	800AH-425	Hex Head Bolt	--	2	--
17	800AH-426	Male Connectors (1 At Top End)	4		
	800AH-427	Male Connector (At Top End)	1		
	800AH-428	Male Elbow (At Top End)	1		
18	800AH-429	Hose Fittings	6		
19	800AH-430	Hose (Specify Lift)	3		
20	800AH-448	Wire Rope (Specify Lift)	1		
21	800AH-459	Cable Connectors	2		
22	800AH-460	Wire Rope Thimble	1		

Notes

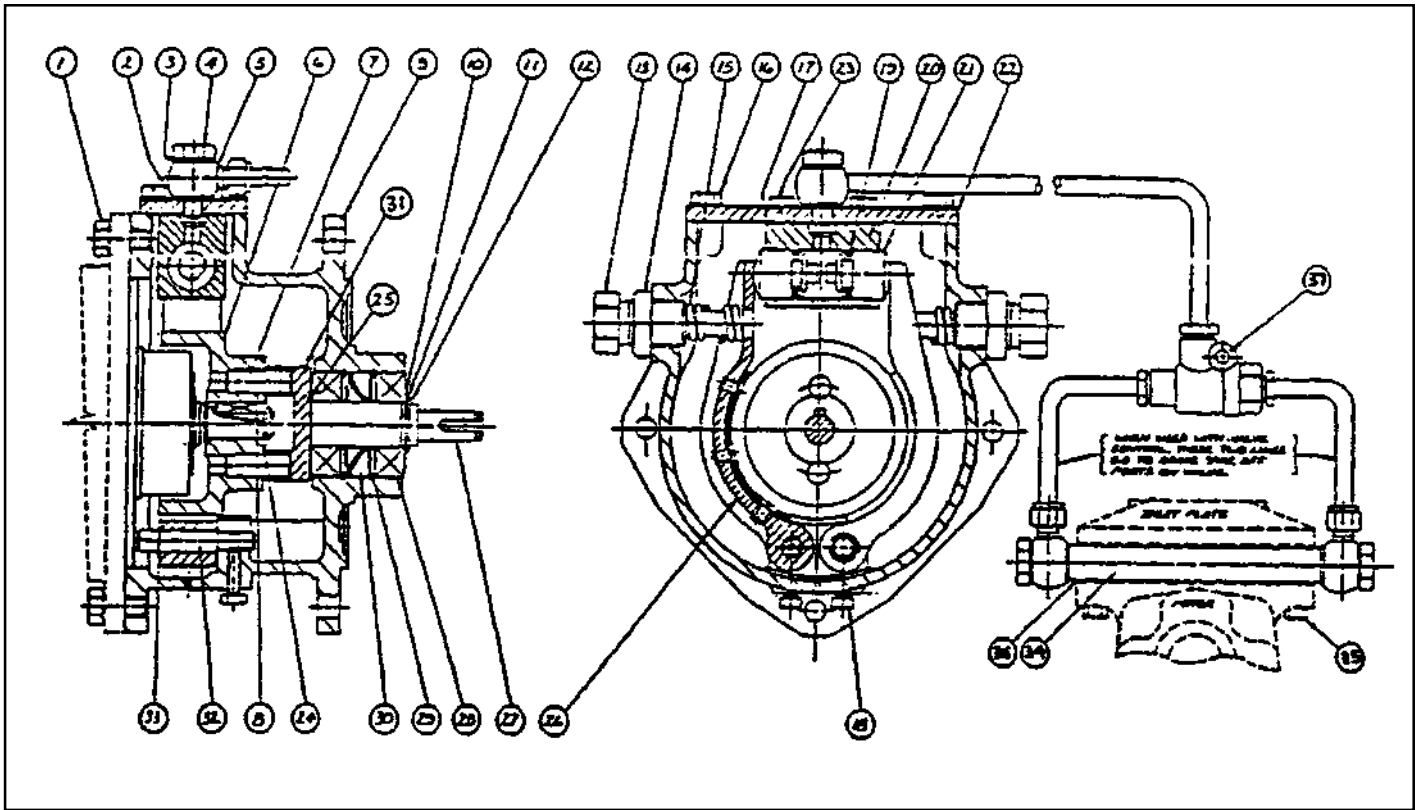

Figure 5. Brake Parts

Ref. No.	Part Number For			Description	Qty Req'd.
	RM210	RM310	RM410		
1	700AH-500	700AH-1500	700AH-2500	Brake Assembly	1
	700AH-501	700AH-1501	700AH-1501	Hex Head Bolt	4
2	700AH-502	700AH-502	700AH-503	Banjo Washer	1
3	700AH-503	700AH-503	--	Banjo Washer	1
4	700AH-504	700AH-504	700AH-2504	Banjo Bolt	1
5	700AH-505	700AH-505	700AH-505	Banjo Body	1
6	700AH-506	700AH-1506	700AH-2506	Brake Wheel	1
7	700AH-507	700AH-1507	700AH-1507	Dowel Pin	2
8	700AH-508	700AH-1508	--	Key	1
9	700AH-509	700AH-1509	700AH-2509	Brake Housing	1
10	700AH-510	700AH-1510	700AH-2510	Output Shaft Shims	As Req'd.
11	700AH-511	700AH-1511	--	Output Shaft Spacer	1
	--	--	700AH-2511	Output Shaft Spacer	2
12	700AH-512	700AH-1512	700AH-2512	External Circlip	1
13	700AH-513	700AH-513	700AH-2513	Spring Adjuster	2
14	700AH-514	700AH-514	700AH-2514	Backnut	2
15	700AH-515	700AH-1515	700AH-2515	Compression Spring	2
16	700AH-516	700AH-1516	--	Hex Head Bolt	4
	--	--	700AH-1516	Hex Head Bolt	8
17	700AH-517	700AH-1517	700AH-2517	Piston Block Gasket	1
18	700AH-518	700AH-1518	--	Hex Head Bolt	2
19	700AH-519	700AH-1519	700AH-2519	U Packing	2
20	700AH-520	700AH-1520	700AH-2520	Piston Block	1
21	700AH-521	700AH-1521	700AH-2521	Piston	2
22	700AH-522	700AH-1522	700AH-2522	Block Support Plate	1
23	700AH-523	700AH-523	--	Hex Head Bolt	2
24	700AH-524	700AH-1524	700AH-2524	External Circlip	1
25	--	--	700AH-2525	Key (Not Shown)	1

Figure 5. Brake Parts (Continued)

Ref. No.	Part Number For			Description	Qty Req'd.
	RM210	RM310	RM410		
26	700AH-526	700AH-1526	700AH-2526	Brake Shoe Assembly	2
27	700AH-527	700AH-1527	700AH-2527	Output Shaft	1
28	700AH-528	700AH-1528	700AH-2528	Output Bearing	2
29	700AH-529	700AH-1529	700AH-1529	Internal Circlip	2
30	700AH-530	700AH-1530	700AH-2530	Oil Seal	1
	--	--	700AH-2531	Sleeve (Not Shown)	1
31	--	--	700AH-2532	Brake Shaft Driver	1
32	700AH-533	700AH-1533	700AH-2533	Brake Shoe Pivot	2
33	700AH-534	700AH-1534	--	External Circlip	2
34	700AH-535	700AH-1535	--	Adaptor Plate	1
35	700AH-536	700AH-1536	--	Hex Head Bolt	4
36	700AH-537	700AH-1537	--	Gasket	2
37	700AH-538	700AH-538	--	Shuttle Valve	1

Notes

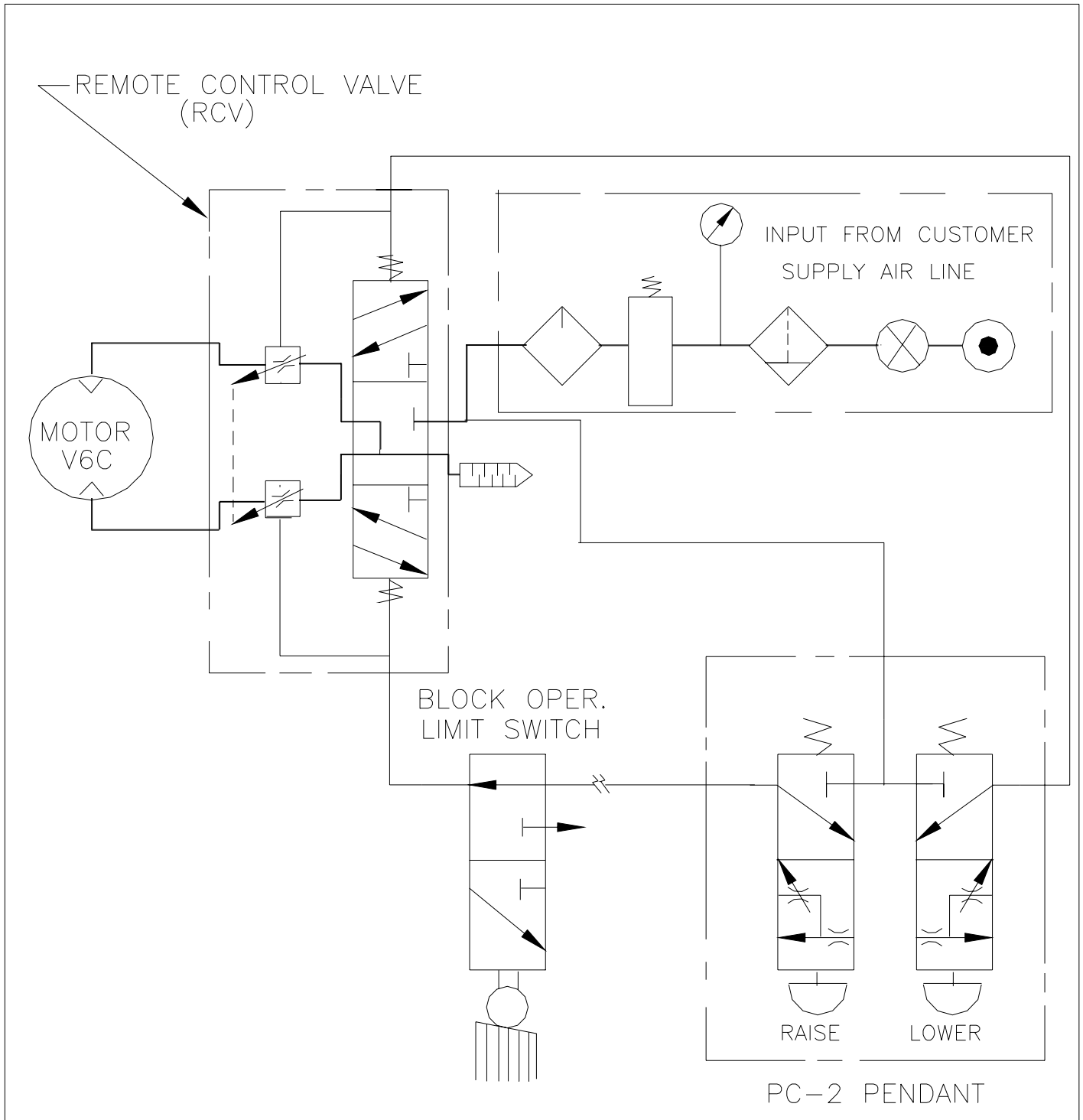

NO.	CHANGE	DATE	ITL.	--- SCHEMATIC ---	
				AIR CONTROL	
				"800" SERIES AIR HOISTS	
			SC. ---	 LIFT-TECH INTERNATIONAL, division of COLUMBUS MCKINNON CORPORATION MUSKEGON, MICHIGAN 49443-0769	
			DA.		
			DR.		SHEET 1 OF 2 SHEETS
			CK. AP.		116115

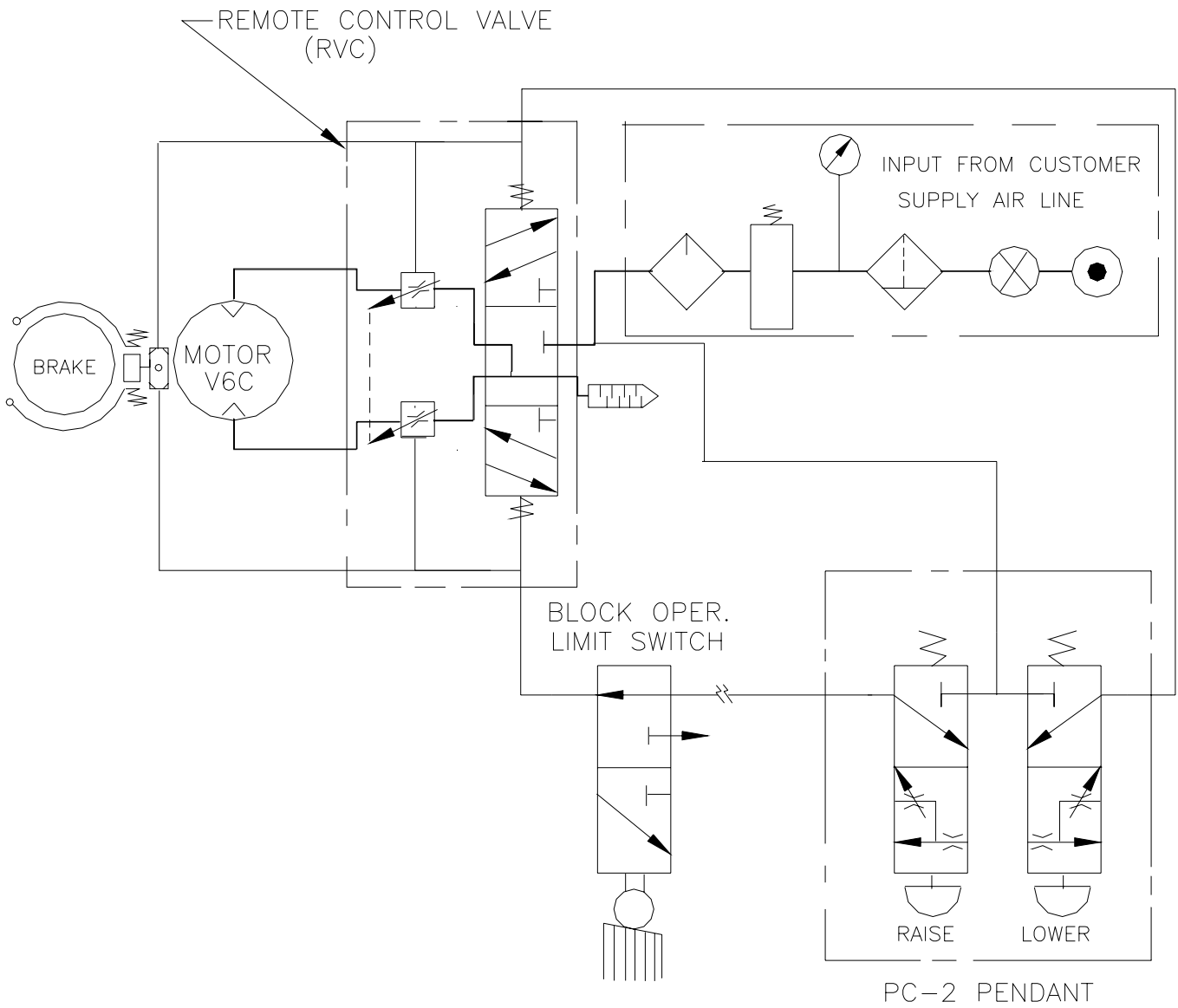

NO.	CHANGE	DATE	ITL.	-- SCHEMATIC --	
				AIR CONTROL	
				"800" SERIES AIR HOISTS	
				WITH MOTOR BRAKE	
			SC. — — —	 LIFT-TECH INTERNATIONAL, division of COLUMBUS MCKINNON CORPORATION MUSKEGON, MICHIGAN 49443-0769	
			DA. 10/16/90		
			DR.	SHEET 1 OF 2 SHEETS	
			CK.	1 1 6 1 1 6	
			AP.		

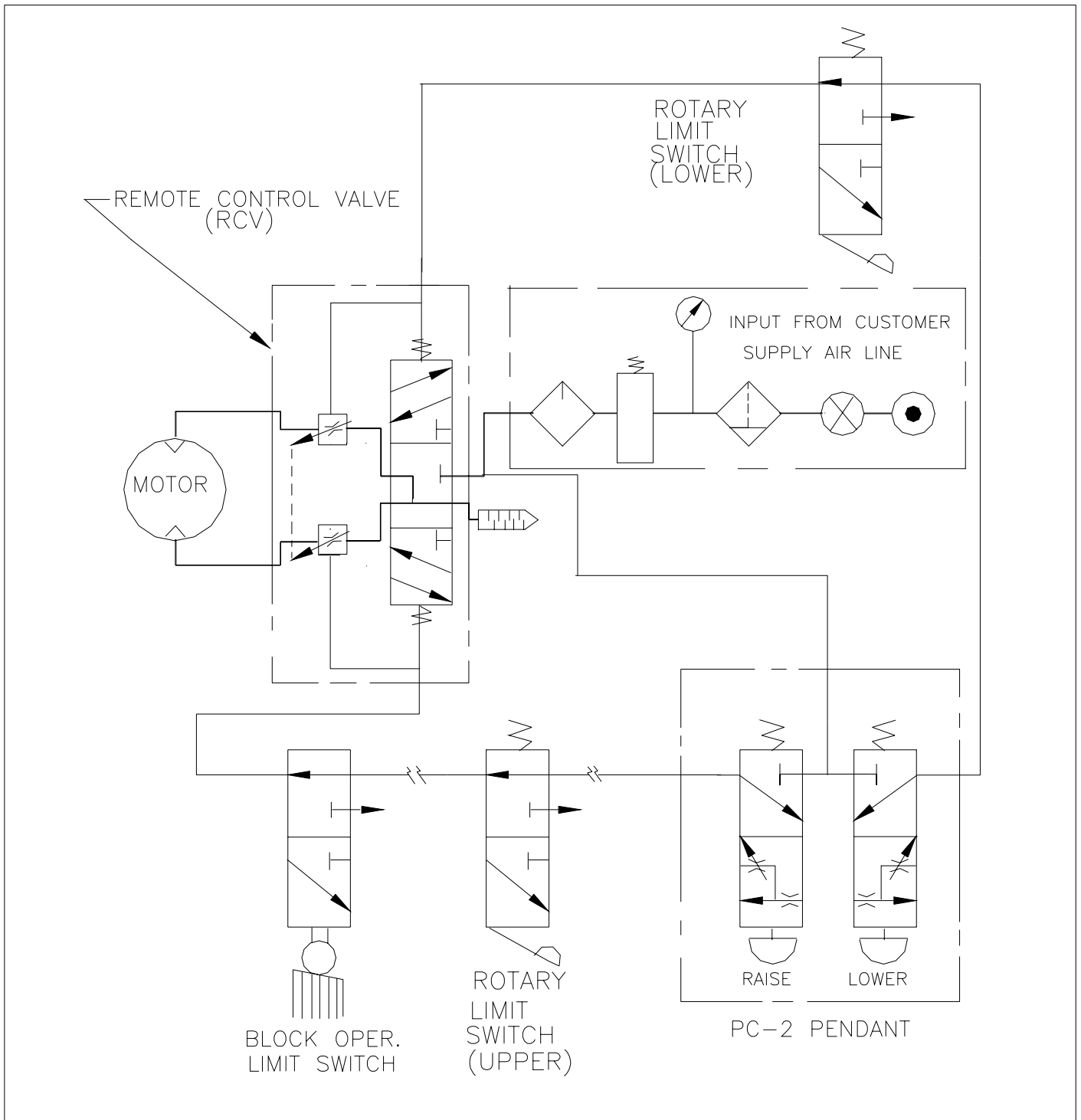

NO.	CHANGE	DATE	ITL.	-- SCHEMATIC --
				AIR CONTROL
				"800" AIR HOISTS
				WITH ROTARY LIMIT SWITCH
			SC. — — —	 LIFT-TECH INTERNATIONAL, division of COLUMBUS MCKINNON CORPORATION MUSKEGON, MICHIGAN 49443-0769
			DA. 10/16/90	
			DR.	SHEET 1 OF 2 SHEETS
			CK.	116117
			AP.	

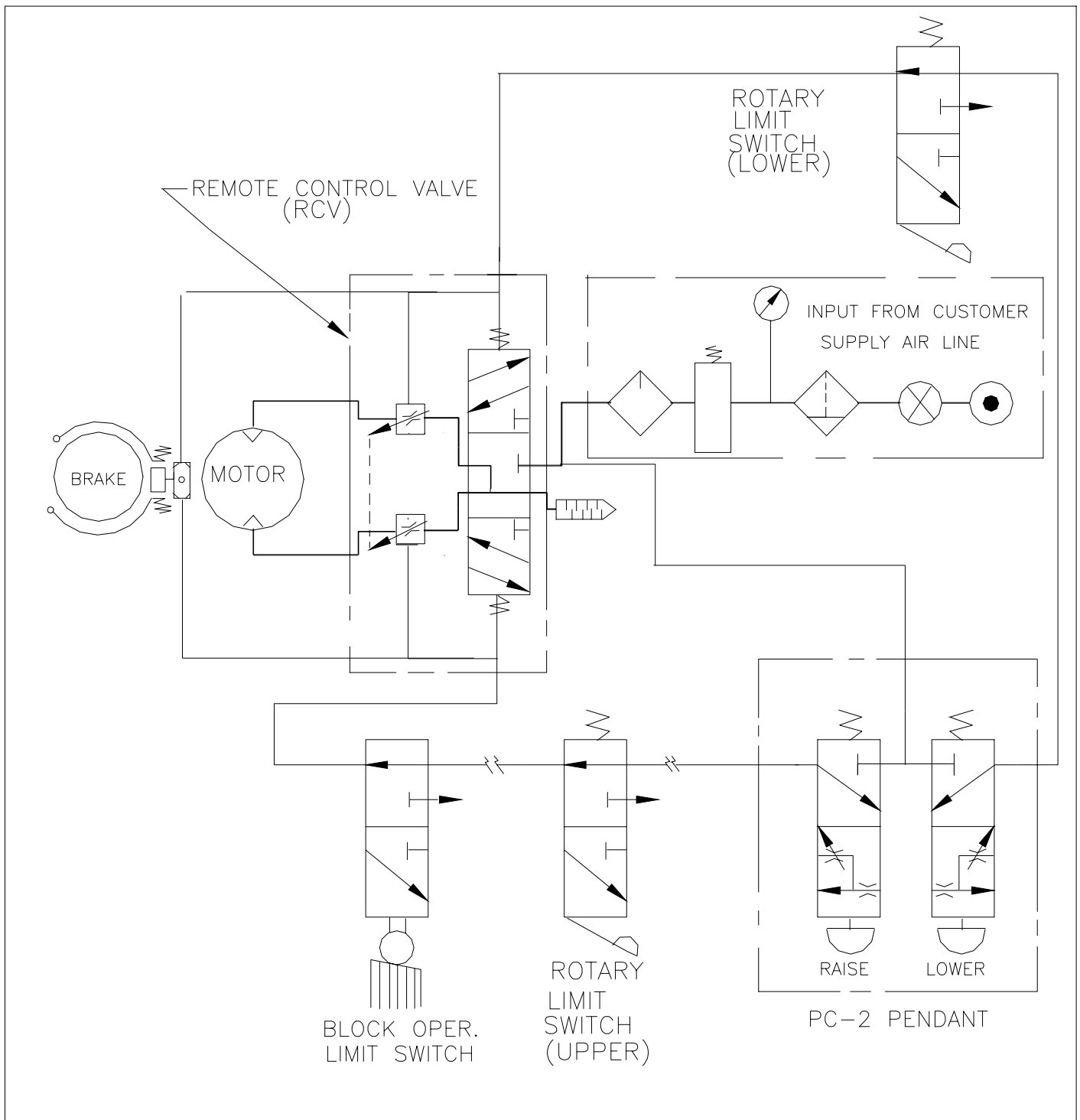

NO.	CHANGE	DATE	ITL.	-- SCHEMATIC --	
				AIR CONTROL	
				"800" AIR HOISTS	
				WITH ROTARY LIMIT SWITCH	
				AND WITH AIR MOTOR BRAKE	
			SC. — — —	 LIFT-TECH INTERNATIONAL, division of COLUMBUS MCKINNON CORPORATION MUSKEGON, MICHIGAN 49443-0769	
			DA. 10/16/90		
			DR.	SHEET	1 OF 2 SHEETS
			CK.	116118	
			AP.		