

BUDGIT®

Instructions and Parts List Motor Driven Trolleys 1/4 - 7½ Ton Rated Loads

GENERAL

These Motor Driven Trolleys are designed for use on BUDGIT coil chain electric hoists. They attach directly to a suspension bracket or mounting lug at top of hoist. Special field conversion kits (see below) are available to accommodate use of these trolleys on existing hook type or lug mounted, push button electric hoists to convert them to motor driven suspension.

Specifications herein subject to change without notice.

A standard 3 ton Motor Driven Trolley is illustrated in Figure 1. The push button station and cable assembly and optional items such as fuse kit, mainline contactor or ballast resistors will be mounted on the trolley and completely wired. Current collector assemblies, when ordered, will be shipped loose.

Assembly of your new trolley to your electric hoist and installation of the complete unit on its runway beam can be accomplished with a minimum of effort by following the instructions given below.

⚠WARNING

This equipment is not suitable or designed to be used in conjunction with lifting or lowering persons.

⚠WARNING

Since rigid mounting does not allow hoist to rotate with pull of load, rigid mounted motor driven trolleys must not be used with hoists having roller type load chain.

BUDGIT HOIST FIELD CONVERSION KITS

Catalog No.	Description
901821	Electrical Adaptor Kit - 115/1/60 A.C.
901822	Electrical Adaptor Kit - 230/1/60 A.C.
901823	Electrical Adaptor Kit - 208,230/460, 575/3/60 A.C.
905421	Lug Suspension Kit - 1/4 to 1 Ton
905422	Lug Suspension Kit - 2 Ton
905424	Lug Suspension Kit - 3 Ton

Above electrical adaptor kits are used for changeover of hoist electrical system to tie-in with trolley electrical system. Hoist power cable and push button control cable are replaced by a 6 or 7 conductor cable assembly (depending on power supply) which connects into terminal strip in trolley control panel. Above lug suspension kits contain a suspension lug assembly which is installed in place of the hoist upper hook. Instructions for installing these kits are not included in this booklet. They are furnished in each kit.

THE INFORMATION CONTAINED IN THIS MANUAL IS FOR INFORMATIONAL PURPOSES ONLY AND BUDGIT DOES NOT WARRANT OR OTHERWISE GUARANTEE (IMPLIEDLY OR EXPRESSLY) ANYTHING OTHER THAN THE COMPONENTS THAT BUDGIT MANUFACTURES AND ASSUMES NO LEGAL RESPONSIBILITY (INCLUDING BUT NOT LIMITED TO CONSEQUENTIAL DAMAGES) FOR INFORMATION CONTAINED IN THIS MANUAL.

ASSEMBLY OF TROLLEY TO HOIST

Note: If trolley is to be used on an existing BUDGIT hoist, the necessary hoist conversion kits should be first installed following instructions furnished with kit.

Place hoist on workbench, suspension lug facing up, and proceed as follows:

1. On BUDGIT hoists, determine whether hoist is to be suspended with frame parallel to runway I-beam or cross mounted (90° to beam), then make certain that lug on hoist is properly oriented and installed before any attachment to trolley. Trolleys for hoists through 1 ton may be parallel mounted and should have the electrical enclosure opposite the tail end of the load chain or chain container. The 2 through 3 ton BUDGIT hoists are cross mounted so that the multiple reeving is parallel to the beam and the trolley electrical enclosure should be on the same side as the hoist electrical enclosure.

2. Determine proper spacing for trolley side plates so that adequate wheel clearance (approximately 1/8") is provided on both sides of I-beam, between inside faces of wheel flanges and edges of bottom beam flange. Proper spacing is obtained by varying the number of spacer washers (furnished with trolley) installed on suspension cross pins between suspension lug and trolley side plates (Figure 2).

12681



Figure 1. Standard Trolley

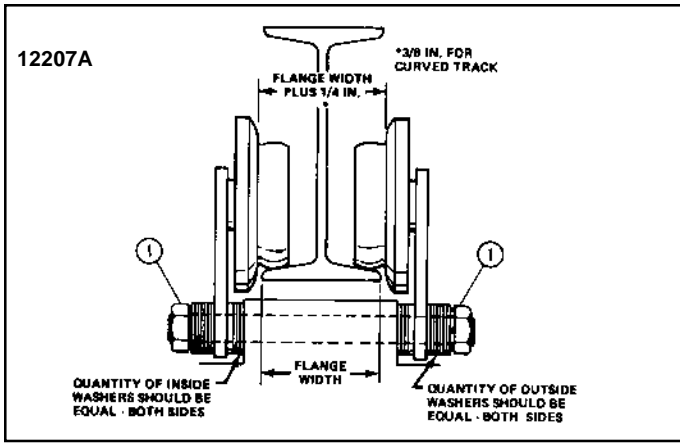

Figure 2. Proper Wheel Spacing

3. Due to manufacturing tolerances, I-beams having the same size designations may have varying dimensions making it impossible to prescribe the specific number of spacer washers required between trolley side plates and suspension lug for any given beam size. It will, therefore, be necessary to determine the spacer washer requirement by "trial and error" assembly.

a. First measure the exact width of bottom flange on runway beam, and then add 1/4" to that measurement (3/8" for curved beam). The total is the required distance between inside faces of wheel flanges to obtain satisfactory wheel operating clearance. See Figure 2.

b. Temporarily assemble trolley to hoist using about 3 or 4 washers at each end of suspension pins, between side plates and suspension lug. Tighten pin nuts for accurate check of spacing.

c. Measure distance between inside faces of wheel flanges and compare with the total dimension obtained in paragraph a. above.

d. Remove trolley sides and add or remove an equal number of inside spacer washers as required to obtain proper distance between wheels.

e. When wheel spacing is correct, remaining spacer washers are to be installed' on outside ends of suspension pins (see note below) and the pins then secured with lockwashers and hex nuts. The nuts (1, Figure 2) should not be completely tightened until after hoist and trolley are mounted on runway beam.

Note: It is important that all spacer washers that come with trolley be used. Install remaining spacer washers equally on outside ends of pins.

4. Open cover on trolley electrical panel enclosure. Remove one knockout from enclosure and thread hoist flexible cable leads through hole. Secure box type connector with locknut and connect leads to terminal strip in accordance with appropriate wiring diagrams furnished with trolley.

CURRENT COLLECTORS

1. Current collectors are not standard and must be ordered as an option. They are shipped in a separate carton and must be installed in field.

2. Determine collector arrangement on trolley before starting assembly (i.e., whether all on one side or on two sides.)

3. Assemble collector bracket with hardware provided. Secure lightly for later adjustment.

4. Arrange collectors on pole in approximate locations and finger tighten to pole.

5. Open cover on trolley electrical panel. Feed wire leads from collector shoe terminals into trolley electrical panel through box type connector in enclosure. Connect collector wire leads to terminal strip in accordance with appropriate wiring diagrams furnished with trolley. Close panel cover.

6. If trolley is equipped with a mainline disconnect panel and/or fuse panel, connect the collector wire leads per "Fuse and Mainline Disconnect Panels" section.

INSTALLING TROLLEY AND HOIST

1. Hoist and trolley combination may be installed on runway beam by either of two methods.

▲WARNING

Be certain that electrical power supply to runway current conductors (if used) is "off" and locked in the open position.

a. If one end of beam is open or exposed, trolley may be installed by sliding it onto beam.

b. If trolley cannot be slid over end of beam, remove hex nuts (1, Figure 2), lockwashers and outer spacer washers from pins on one side of trolley. Spread or remove one side plate to facilitate positioning trolley over bottom flange of beam. Reinstall, side plate, outer spacer washers, lockwashers and hex nuts on suspension pins.

▲WARNING

After trolley has been installed on beam, make sure suitable stop(s) is secured on open ended beams to prevent trolley from rolling off the beam. (Stops should contact trolley side plates, not wheels.) Make certain that all spacer washers and lockwashers are in place on suspension pins and that hex nuts are tight. Recheck clearance dimension between wheel flanges and beam flanges (Figure 2).

2. Engage slide collector shoes with runway conductor bars and make final adjustment to pole bracket and collector spacing. Tighten securely.

▲CAUTION

Power supply must be same voltage, phase and frequency as specified on hoist and trolley motor nameplates.

3. Follow National, State and Local electrical codes when providing electrical service to hoist and trolley. Make electrical

connections using the wiring diagrams furnished with the trolley and the wiring diagram furnished with the hoist. **Do not attempt to operate trolley or hoist before completing "Pre-Operation Checks and Adjustments."**

⚠WARNING

This equipment must be effectively grounded according to the National Electrical Code, or other applicable codes. If the grounding method used is through the trolley wheels, then each section of track must be grounded by metal-to-metal connection to the building ground. Certain environments may prevent proper grounding by this means and in this case a separate grounding conductor should be provided.

ATTACH PUSH BUTTON STATION STRAIN CABLE

Trolleys ordered for use with hoists are shipped from the factory with the upper end of the push button station strain cable unconnected. If this is the case, it will be necessary to remove rope thimble from loose end of strain cable and attach strain cable as shown in either Figure 3 or Figure 4.

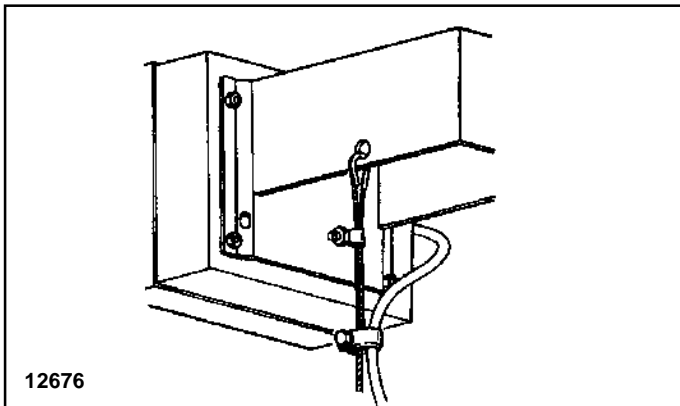

Figure 3. Push Button Strain Cable Attachment to 1/4 thru 2 ton Budgit Hoist Trolleys

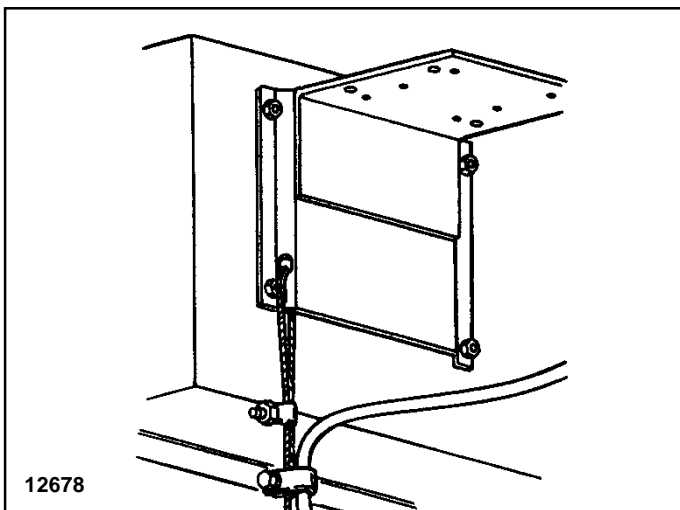

Figure 4. Push Button Strain Cable Attachment to 3 thru 7-1/2 ton Budgit Hoist Trolleys

CONNECTING TROLLEY TO ELECTRICAL SERVICE

1. Follow Local, State and National Electric Codes when providing electrical service to hoist. Connect wires in accordance with appropriate trolley wiring diagram. Be certain that the electrical power supply is the same as specified on trolley and hoist motor data plates. On dual voltage hoists and trolleys be certain that connections are made inside the hoist and inside the trolley motor conduit box for the appropriate voltage. On three phase models **DO NOT** attempt to operate trolley or hoist before completing **TESTS AND ADJUSTMENTS FOR 3 PHASE MODELS** which follows.

2. Common methods of connecting trolley to power supply are current collectors, previously described and flexible cable (tag line, festooned or cable reel).

Note: A grounding type male plug or permanent connection in an outlet box may be used for wiring tag line or festooned cable to power supply.

⚠CAUTION

Power supply must be same voltage, frequency and phase as specified on hoist and trolley nameplates.

⚠WARNING

All equipment must be effectively grounded electrically.

Grounding is accomplished in the following manner:

(1) Flexible cable or four collector system.

Connect green identified ground wire to separate grounding screw in trolley electrical enclosure.

(2) Three collector system.

Trolley is considered grounded through trolley wheels to properly grounded track sections. (Ref. N.E.C. Article 610).

TEST AND ADJUSTMENTS FOR 3 PHASE MODELS

⚠WARNING

Three phase hoists must be properly phased each time they are installed or moved to a new power source. Unless this is done, serious damage to the hoist can occur with resulting hazard to the operator and load.

1. To properly phase hoists follow these steps.
 - a. Operate "UP" button briefly to determine direction of load hook travel.
 - b. If load hook raises when "UP" button is pressed, phase is correct and hoist may be operated.
 - c. If load hook lowers, hoist is "Reverse Phased" and must be corrected by interchanging any two leads **at power source** connection.

Do not change internal wiring of hoist or trolley.

2. Check hoist upper and lower limit stop operation to determine if limit stop functions properly in both directions. Refer to hoist "Operation and Service Manual" under "Testing Hoist" for method to be followed.
3. Position hoist-trolley combination on I-beam so that enough clear track is available to allow travel of trolley in two directions to permit checking "RIGHT" and "LEFT" traverse operation.

Note

Three Phase Motors: If it is desired to reverse the direction of **trolley travel** in relation to the push button markings, turn POWER OFF and interchange connections of motor leads "T-1" and "T-2" at trolley motor.

Single Phase Motors: It is not recommended that the user attempt to reverse direction of trolley travel with respect to push button station markings. If application requires this be done, contact factory for special instructions.

4. Adjust Ballast Resistors (if furnished).

a. Ballast resistors installed on 3 phase motor driven trolleys provide a "cushion-start" effect which is helpful in reducing load swing during acceleration. It will be necessary to adjust resistor slide bands with hoist under load as directed below to obtain the desired rate of acceleration.

- (4) Turn power "ON" and with maximum load to be traversed suspended from hoist, press "RIGHT" or "LEFT" trolley button and note speed of trolley acceleration. If trolley does not move or accelerates too slowly, turn power "OFF" and move all three slide bands approximately 1" away from jumper end. Turn power on and repeat above test. Continue above procedure until desired acceleration is obtained.

- (5) Replace resistor cover.

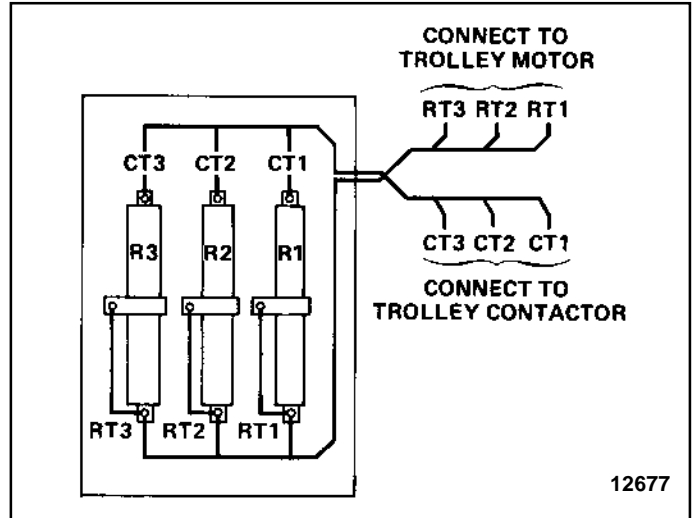

Figure 6. Resistor Wiring Diagram

⚠ WARNING

Ballast resistors are neither suitable nor intended for use in reducing maximum trolley running speed.

b. Resistor slide bands (taps) are approximately set when shipped from factory. Field adjustments for desired acceleration should be made by user with maximum load to be moved suspended from hoist as follows:

- (1) Turn power "OFF" at power source.
- (2) Remove resistor cover. Discard any paper covering resistors.
- (3) Loosen the three slide bands and move them to the extreme end to which jumpers are attached. This provides maximum resistance resulting in reduced motor voltage and motor torque.

5. Adjust Electronic Acceleration Control (if furnished).

There are two adjustments on the BUDGIT Electronic Acceleration Control (sometimes called EAC). The upper adjustment (Torque Adjustment) is for the initial torque and the lower adjustment (Time Adjustment) is the ramp time, or acceleration, adjustment.

To adjust the unit, turn both adjustments fully counter clockwise. With the trolley and hoist unloaded, increase the initial Torque Adjustment, by turning clockwise, until the trolley moves as soon as the push button is depressed. This adjustment is usually adequate.

⚠ CAUTION

To prevent damage to trolley motor, be certain the three slide bands are IN-LINE HORIZONTALLY on their respective resistors after any adjustment. DO NOT ROTATE slide bands on their resistors. This may cause electrical shorting.

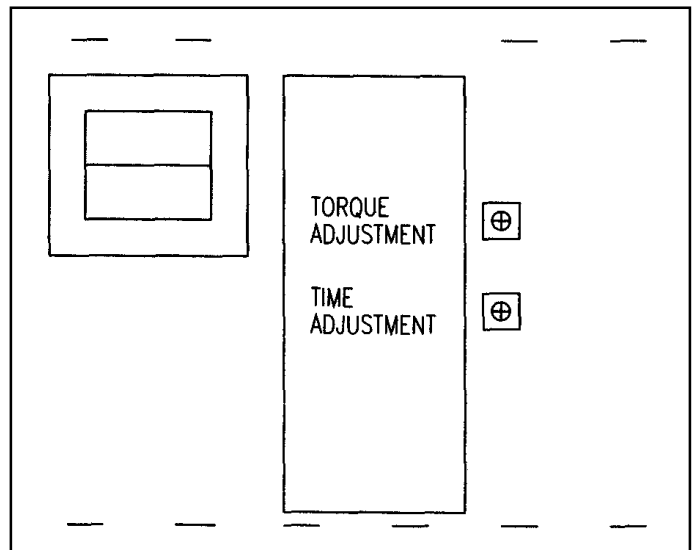

Electronic Acceleration Control

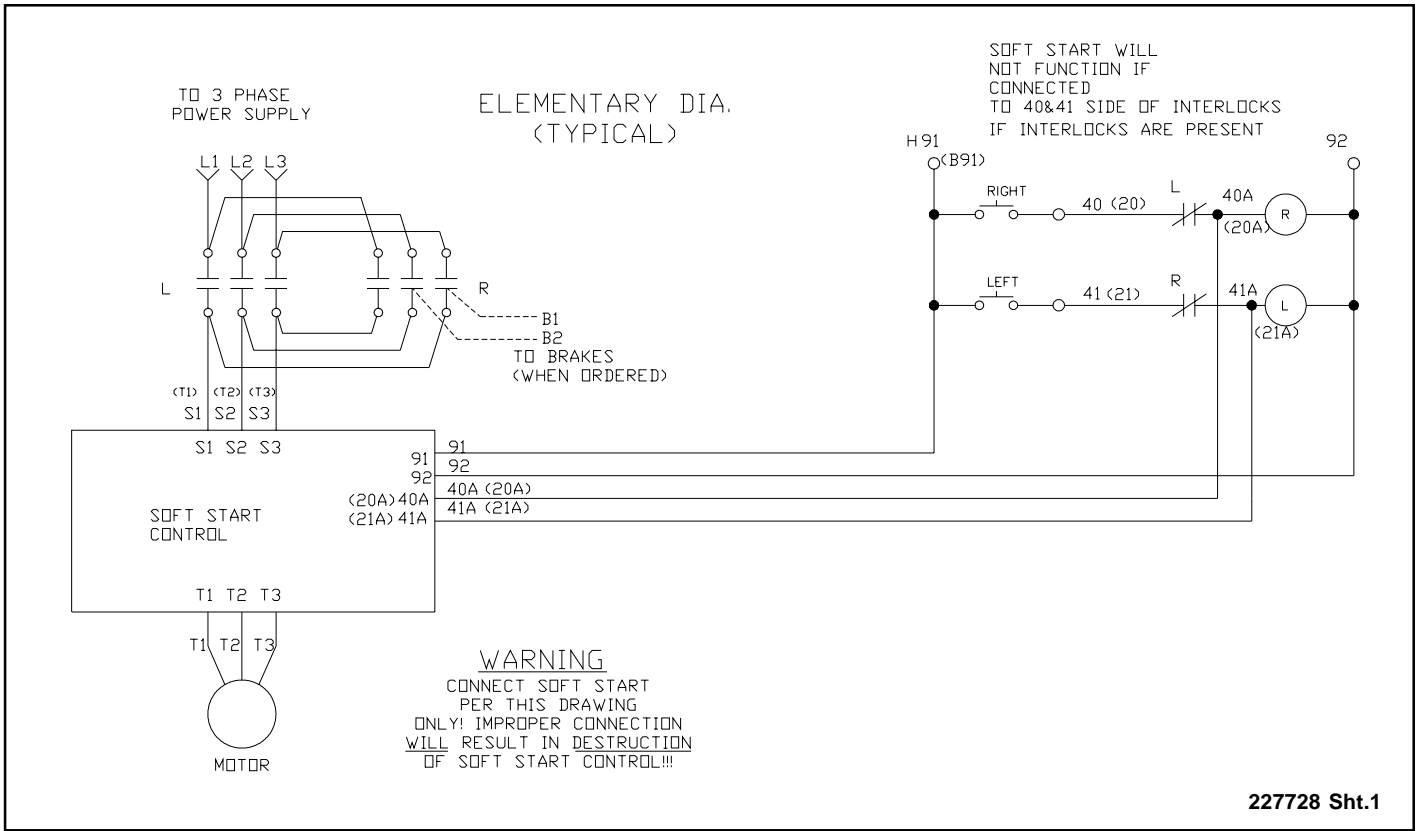

**Connection Diagram
Electronic Acceleration Control
1 Speed**

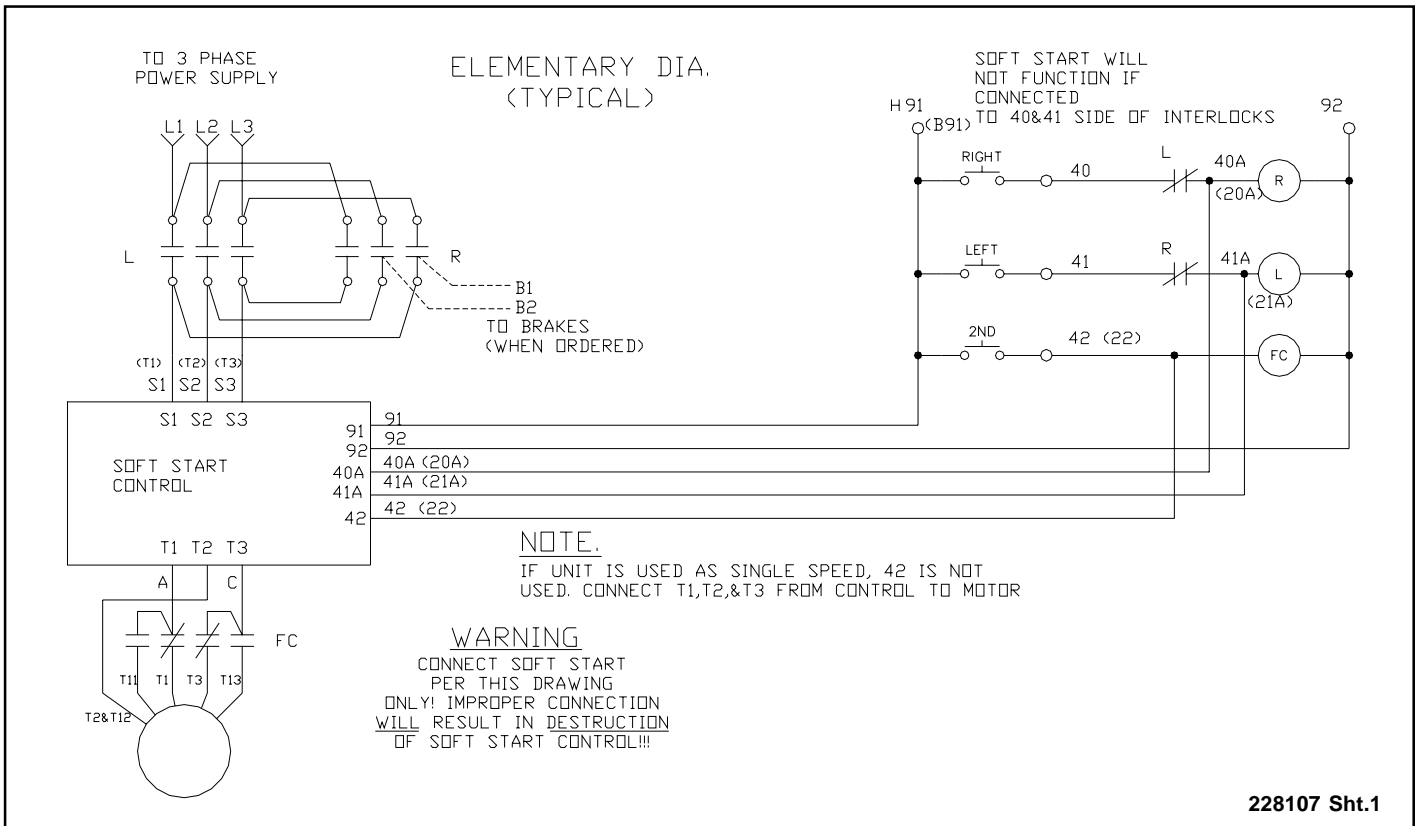

**Connection Diagram
Electronic Acceleration Control
2 Speed**

Should the trolley not start promptly at normal loads, adjust the Time Adjustment clockwise until it operated in a satisfactory manner. Torque Adjustment may also be adjusted according to insure proper operation.

To adjust the unit prior to installation, when the trolley is not installed, turn the Torque and Time Adjustments fully counterclockwise. Turn the Torque Adjustment clockwise until the motor just starts when the push button is depressed and then turn the additional 5 degrees.

TESTING SINGLE PHASE TROLLEY MOTOR OPERATION

To check operation of starting winding centrifugal switch, connect ammeter (minimum 10 ampere) to MOTOR lead "T5". Ampere reading must drop to zero in approximately one second when operating trolley in both directions of travel. If ampere reading does not drop to zero, interchange motor lead "T6" with "T7" and recheck. If ampere reading still does not return to zero after above checks have been made, the motor centrifugal switch is defective and must be replaced to avoid motor burn out.

FUSE AND MAINLINE DISCONNECT PANELS

Mainline disconnect panels and/or hoist-trolley fuse panels are provided as options on motor driven trolleys to assist users in complying with OSHA codes. When ordered with trolley, they will be completely installed on trolley and wired into trolley electrical system.

Electrical service is to be connected to trolleys equipped with fuse panels and/or mainline disconnect panels as follows:

1. Fuse Panels Only. Connect leads from power supply to hoist fuse terminals "L-1", "L-2" and "L-3" (3-phase) under hoist fuses. See trolley wiring diagram.
2. Mainline disconnect (furnished with fuse panels only). Connect power supply leads "ML-1", "ML-2" and "ML-3" (3-phase) to the upper power terminals of mainline contactor. Refer to trolley wiring diagram.

should be inspected periodically for evidence of damage or wear, particularly when subjected to unusually severe operating conditions.

2. Lubrication requirements:

- a. Wheel bearings are permanently lubricated and require no additional lubricant.
- b. Drive wheel gears are to be lubricated with an open type gear grease which is heavy, plastic, extreme pressure and tacky; such as MOBILTAC 275 NC or equal.
- c. The right angle worm gear reducer oil is a synthetic lubricant with excellent wear protection capability and long life. This oil does not require changing. When replacing oil due to repairs, use MOBIL SHC 634 or equal.

REPLACEMENT PARTS

The following parts lists and illustrations cover standard model Budget motor driven trolleys. Typical units are used as the basis for the exploded parts illustrations; therefore, certain variations may occur from the parts information given. For this reason always give the catalog number, model number, motor horsepower, voltage, phase and frequency of trolley when ordering replacement parts. For motors, gearboxes and electrical components, give complete nameplate data. Pins referred to in some column headings are trolley suspension pins.

The factory recommends complete replacement of the motor or gearbox. Gearbox service is available, however, from your local authorized Budget repair station.

Use only factory provided replacement parts. Parts may look alike but parts are made of specific materials and processes to achieve specific properties.

The numbers assigned to the parts of our various assemblies in our parts lists are not the part numbers used in manufacturing the part. They are identification numbers, that when given with the trolley serial number, permit us to identify, select or manufacture, and ship the correct part needed for any trolley.

Supply Complete numbers from the identification plate of the gearbox that match the numbers (including digits - where x's appear) in the lower right hand corner of the parts illustration for the motor and gearbox assemblies.

⚠ CAUTION

Power supply must be same voltage, frequency and phase as specified on hoist and trolley nameplates.

MAINTENANCE AND LUBRICATION

1. Budget Motor Driven Trolleys are built to give long service, but

INDEX OF PARTS ILLUSTRATIONS

Title	Figure No.	Page No.
Trolley Frame and Wheels (4" Ø Wheels - 3-1/8" & 5" c/c Pins).....	7	7
Trolley Frame and Wheels (4" Ø Wheels - 6" c/c Pins)	8	8
Trolley Frame and Wheels (6-1/2"Ø Wheels - 6" c/c Pins)	8A	9
Motor and Gearbox Assembly (3-1/8" & 5" c/c Pins)	9	10
Motor and Gearbox Assembly (6" c/c Pins).....	10	11
Electrical Enclosure Mountings	11	12
Electrical Enclosures	12	14
Push Button Station and Conductor Cable Assembly.....	13	16
Current Collectors	14	18
Ballast Resistors	-	19
Electronic Acceleration Control	-	19

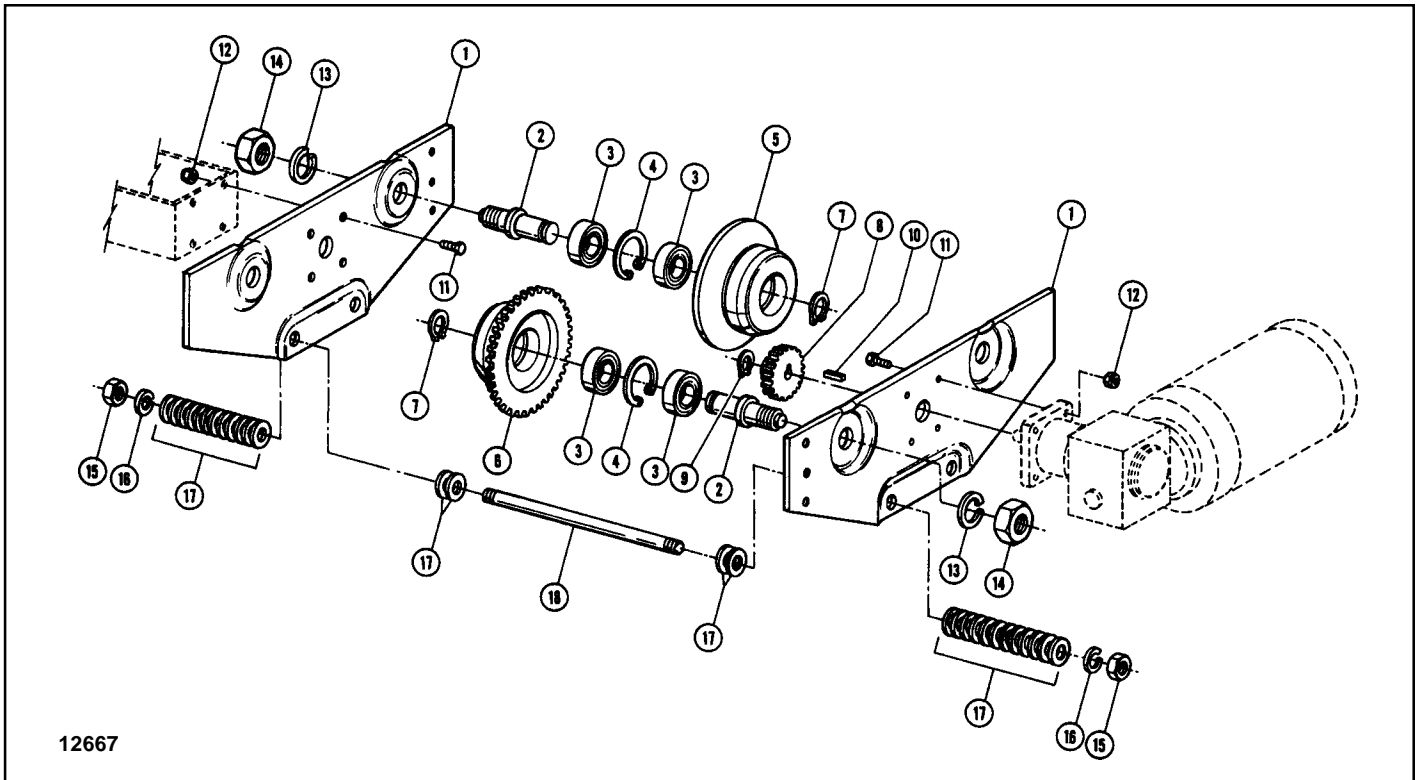

12667

Figure 7. Trolley Frame and Wheels - One Motor
(4"Ø Wheels - 3-1/8" & 5" c/c Pins)

Ref. No.	Description	3-1/8" c/c Pins		5" c/c Pins	
		Part Number	Qty. Req'd.	Part Number	Qty. Req'd.
1	Plate Assembly - Side For 3" to 5" Flange Widths and Patented Track	BET-2700	2	-	-
	For 5-1/8" to 7-1/4" Flange Widths	BET-2701	2	-	-
	For 7-1/2" to 9-1/8" Flange Widths	BET-2702	2	-	-
	For 3-5/8" to 6" Flange Widths and Patented Track	-	-	BET-2703	2
	For 6-1/4" to 8-5/8" Flange Widths	-	-	BET-2704	2
	For 8-7/8" to 11-1/4" Flange Widths	-	-	BET-2705	2
2	Shaft - Wheel	BET-2706	4	BET-2706	4
3	Bearing - Ball	BET-2707	8	BET-2707	8
4	Ring - Retaining	BET-2708	4	BET-2708	4
5	Wheel - Plain (Except Patented Track) For Patented Track Only	BET-2709	2	BET-2709	2
		BET-2710	2	BET-2710	2
6	Wheel - Geared (Except Patented Track) For Patented Track Only	BET-2711	2	BET-2711	2
		BET-2712	2	BET-2712	2
7	Ring - Retaining	BET-2713	4	BET-2713	4
8	Pinion - Motor	BET-2714	1	BET-2715	1
9	Ring - Retaining	BET-2716	1	BET-2716	1
10	Key- Motor Pinion	BET-2717	1	BET-2717	1
11	Screw- Hex Cap	BET-2718	8	BET-2718	8
12	Nut- Serf-locking	BET-2719	8	BET-2719	8
13	Lockwasher	BET-2720	4	BET-2720	4
14	Nut- Hex Jam	BET-2721	4	BET-2721	4
15	Nut - Hex Jam	BET-2722	4	BET-2721	4
16	Lockwasher	BET-2723	4	BET-2720	4
17	Washer - Spacer	BET-2724	56	BET-2725	36
18	Pin - Suspension For 3" to 5" Flange Widths and Patented Track	BET-2726	2	-	-
	For 5-1/8" to 7-1/4" Flange Widths	BET-2727	2	-	-
	For 7-1/2" to 9-1/8" Flange Widths	BET-2728	2	-	-
	For 3-5/8" to 6" Flange Widths and Patented Track	-	-	BET-2729	2
	For 6-1/4" to 8-5/8" Flange Widths	-	-	BET-2730	2
	For 8-7/8" to 11-1/4" Flange Widths	-	-	BET-2731	2

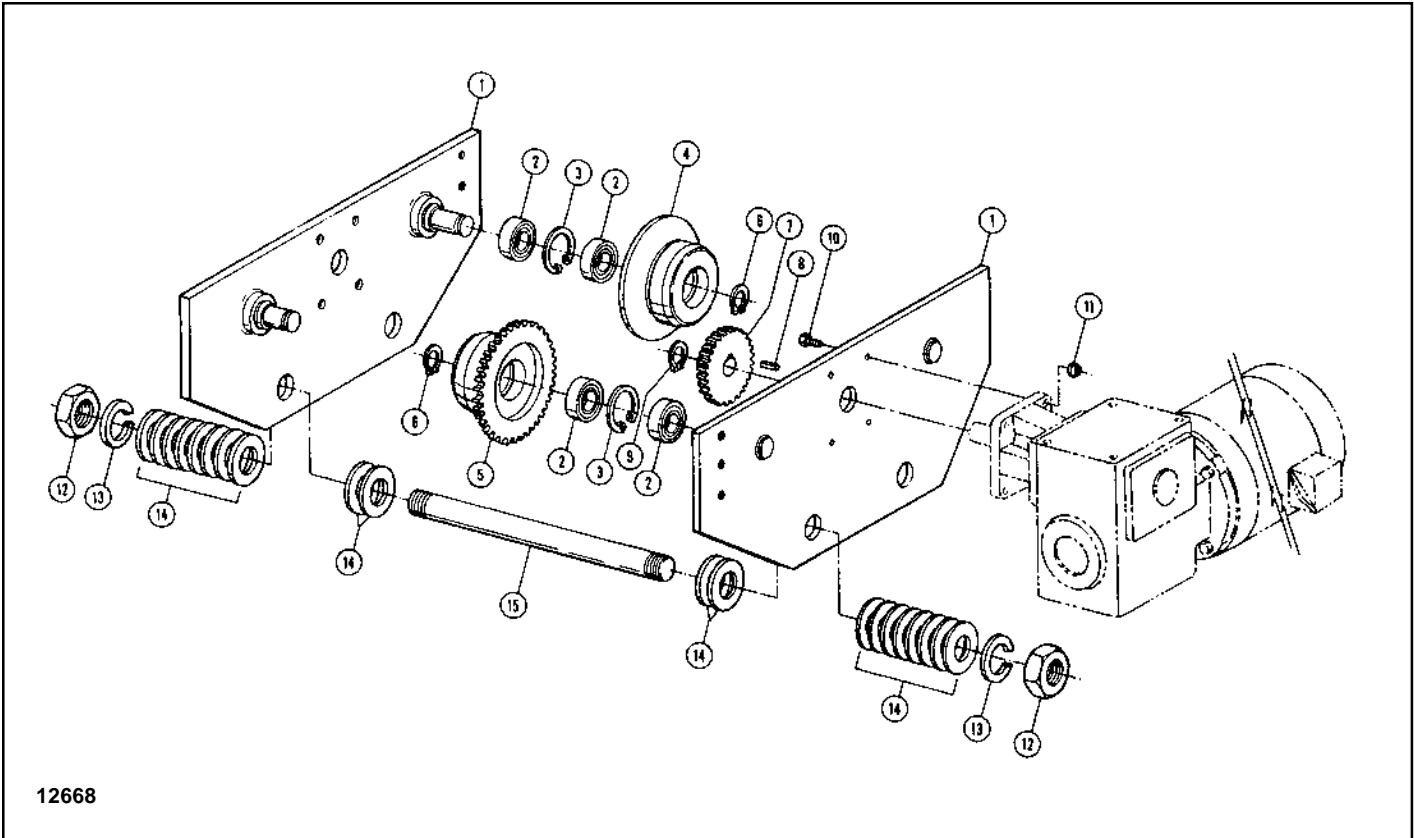

**Figure 8. Trolley Frame and Wheels
(4"Ø Wheels & 6" c/c Pins)**

Ref. No.	Part Number	Description	Qty. Req'd.
1	BET-2800	Plate Assembly - Side For 4" to 6-1/4" Flange Widths and Patented Track	2
	BET-2801	For 6-3/8" to 8-5/8" Flange Widths	2
	BET-2802	For 8-3/4" to 11" Flange Widths	2
2	BET-2803	Bearing - Ball	8
3	BET-2804	Ring - Retaining	4
4	BET-2805	Wheel - Plain (Except Patented Track)	2
	BET-2806	For Patented Track Only	2
5	BET-2807	Wheel - Geared (Except Patented Track)	2
	BET-2808	For Patented Track Only	2
6	BET-2809	Ring - Retaining	4
7	BET-2810	Pinion - Motor	1
8	BET-2811	Key - Motor Pinion	1
9	BET-2812	Ring - Retaining	1
10	BET-2813	Screw - Hex Cap	4
11	BET-2814	Nut - Self-locking	4
12	BET-2815	Nut - Hex Jam	4
13	BET-2816	Lockwasher	4
14	BET-2817	Washer - Spacer	40
15	BET-2818	Pin - Suspension For 4" to 6-1/4" Flange Widths and Patented Track	2
	BET-2819	For 6-3/8" to 8-5/8" Flange Widths	2
	BET-2820	For 8-3/4" to 11" Flange Widths	2

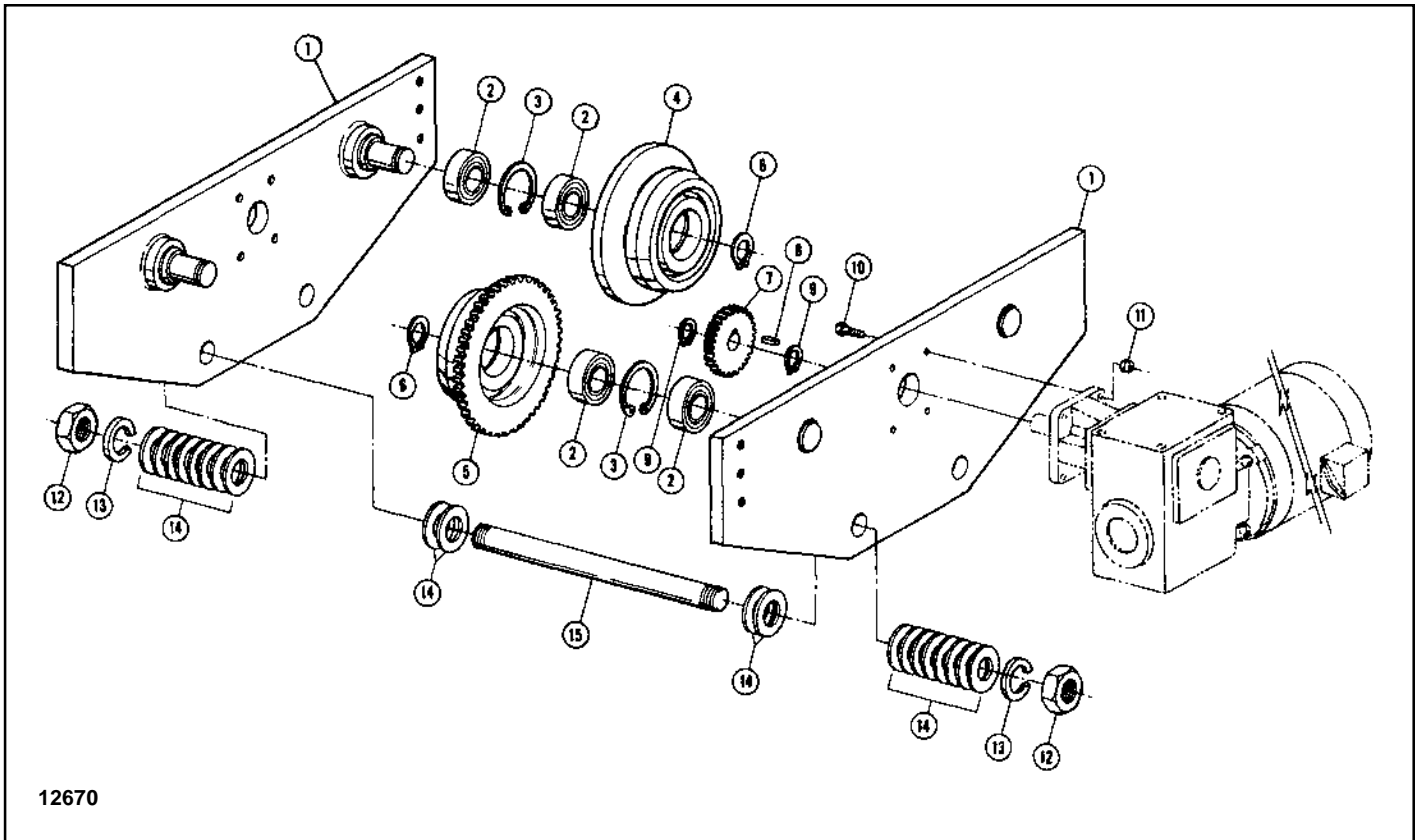
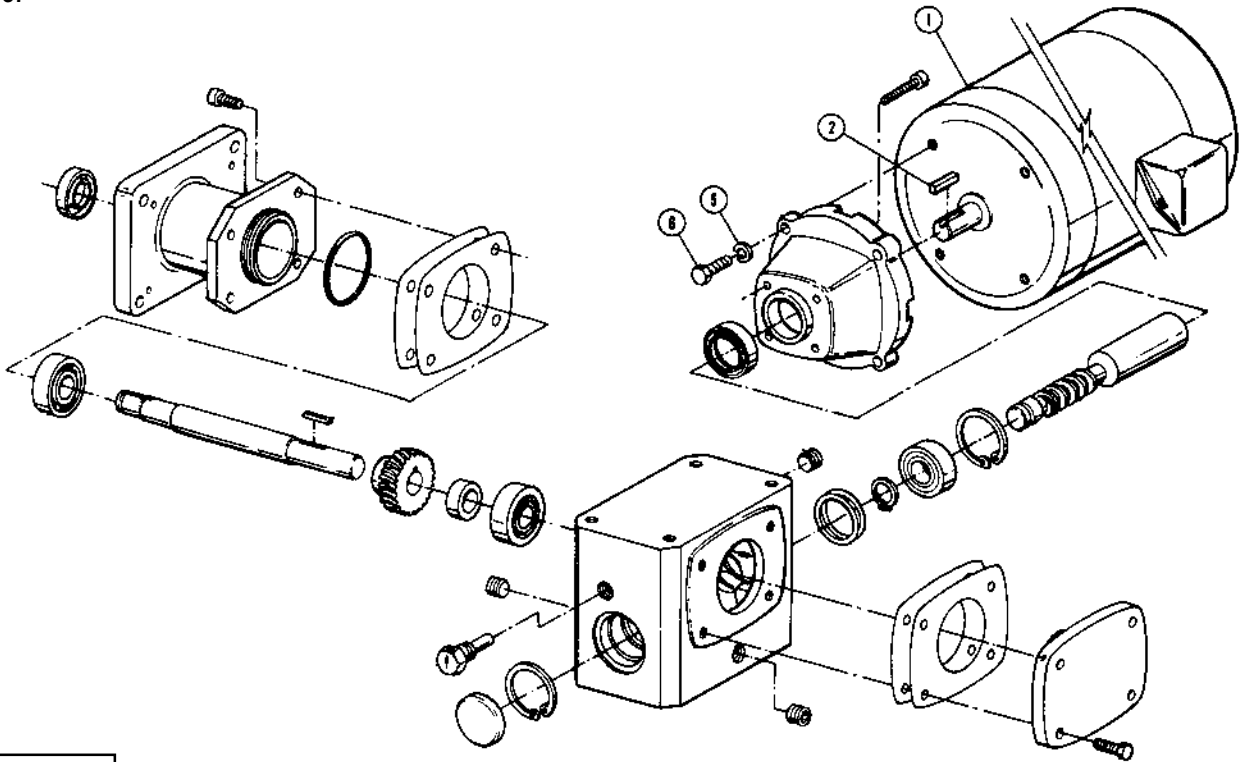

Figure 8A. Trolley Frame and Wheels - One Motor
(6½" Ø Wheels - 6" c/c Pins)

Ref. No.	Description	1¼" Ø Pins	1½" Ø Pins	Qty. Req'd.
		Part No.	Part No.	
1	Plate Assembly - Side For 4" to 6-1/4" Flange Widths and Patented Track For 6-3/8" to 8-5/8" Flange Widths For 8-3/4" to 11" Flange Widths	BET-3800 BET-3802 BET-3804	BET-3801 BET-3803 BET-3805	2 2 2
2	Bearing - Ball	BET-3811	BET-3811	8
3	Ring - Retaining	BET-3813	BET-3813	4
4	Wheel - Plain (Except Patented Track) For Patented Track Only	BET-3815 BET-3817	BET-3815 BET-3817	2 2
5	Wheel - Geared (Except Patented Track) For Patented Track Only	BET-3818 BET-3820	BET-3818 BET-3820	2 2
6	Ring - Retaining	BET-3821	BET-3821	4
7	Pinion - Motor	BET-3823	BET-3823	1
8	Key - Motor Pinion	BET-3824	BET-3824	1
9	Ring - Retaining	BET-3825	BET-3825	2
10	Screw- Hex Cap	BET-3826	BET-3826	4
11	Nut - Self-locking	BET-3828	BET-3828	4
12	Nut - Hex Jam	BET-3829	BET-3830	4
13	Lockwasher	BET-3832	BET-3833	4
14	Washer-Spacer	BET-3835	BET-3836	40
15	Pin - Suspension For 4" to 6-1/4" Flange Widths and Patented Track For 6-3/8" to 8-5/8" Flange Widths For 8-3/4" to 11" Flange Widths	BET-3838 BET-3840 BET-3842	BET-3839 BET-3841 BET-3843	2 2 2

12737



439509-xx
602005-03-E

Figure 9. Motor and Gearbox Assembly
(3-1/8" & 5" c/c Pins)

Notice: Five types of motor and gearbox assemblies have been used for trolleys with 3-1/8" & 5" c/c. When ordering replacement gearbox for 439076-xx gearbox, order new gearbox and motor.

Ordering Instructions: Furnish complete data from motor and gearbox nameplates with parts order. Replacement parts cannot be provided without this information.

Ref. No.	Part Number	Description	Qty. Req'd
	BET-3600	Motor and Gearbox Assembly - Complete	
1	BET-3601	Motor (Includes Ref. No.2)	1
2	BET-3602	Key - Motor (1/8 x 1/8 x 3/4)	1
	BET-3603	Gearbox Assembly - Complete	1
5	BET-3606	Lockwasher (3/8)	4
6	BET-3607	Bolt - Hex Head (3/8 - 16 x 1)	4

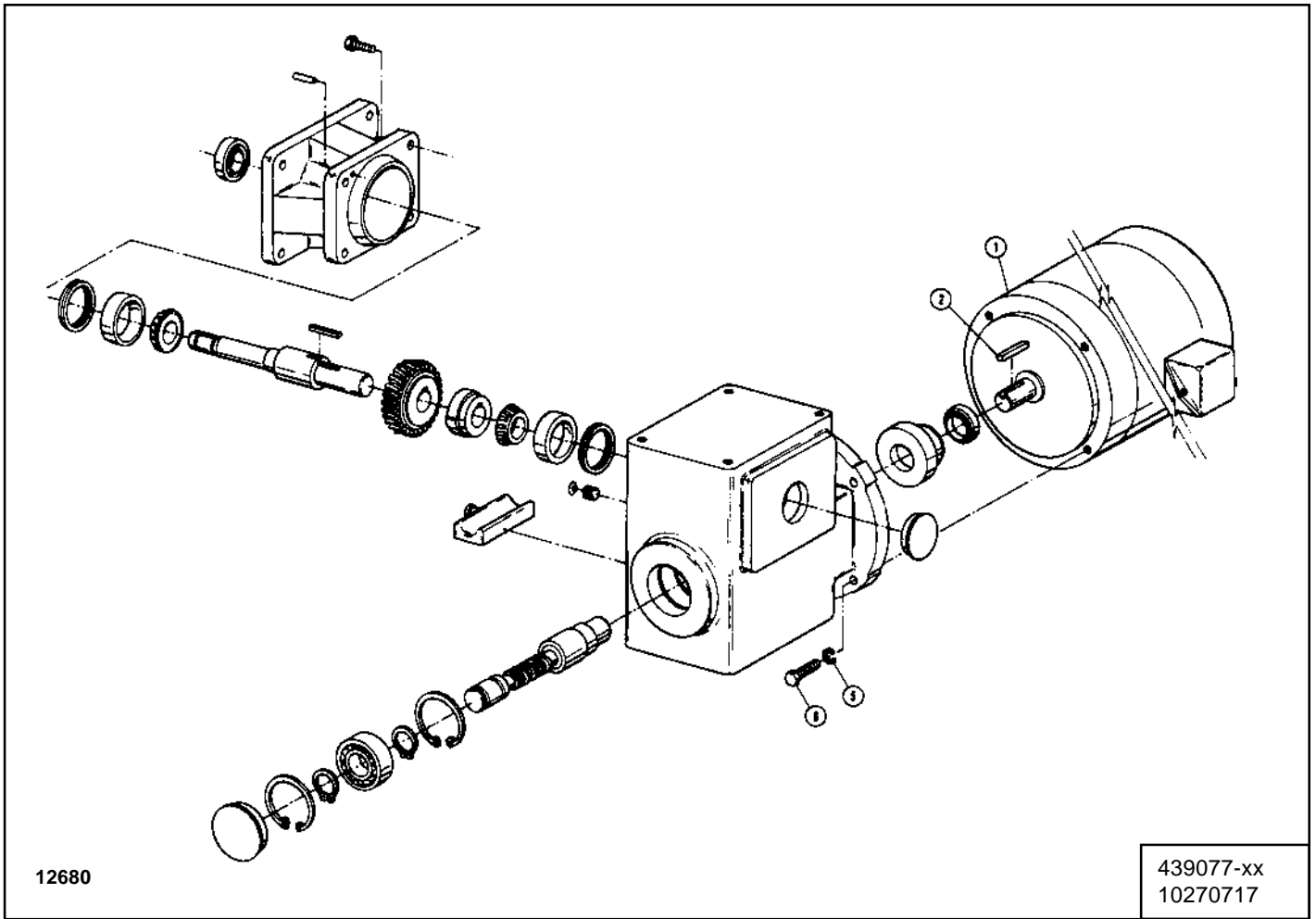

**Figure 10. Motor and Gearbox Assembly
(6" c/c Pins)**

Ordering Instructions: Furnish complete data from motor and gearbox nameplates with parts order.
Replacement parts cannot be provided without this information.

Ref. No.	Part Number	Description	Qty. Req'd
	BET-3000	Motor and Gearbox Assembly - Complete	1
1	BET-3001	Motor (Includes Ref. No.2)	1
2	BET-3002	Key - Motor (3/16 x 3/16 x 1-1/4)	1
	BET-3003	Gearbox Assembly - Complete	1
5		Lockwasher (3/8)	4
6	BET-3007	Bolt- Hex Head (3/8 - 16 x 7/8)	4

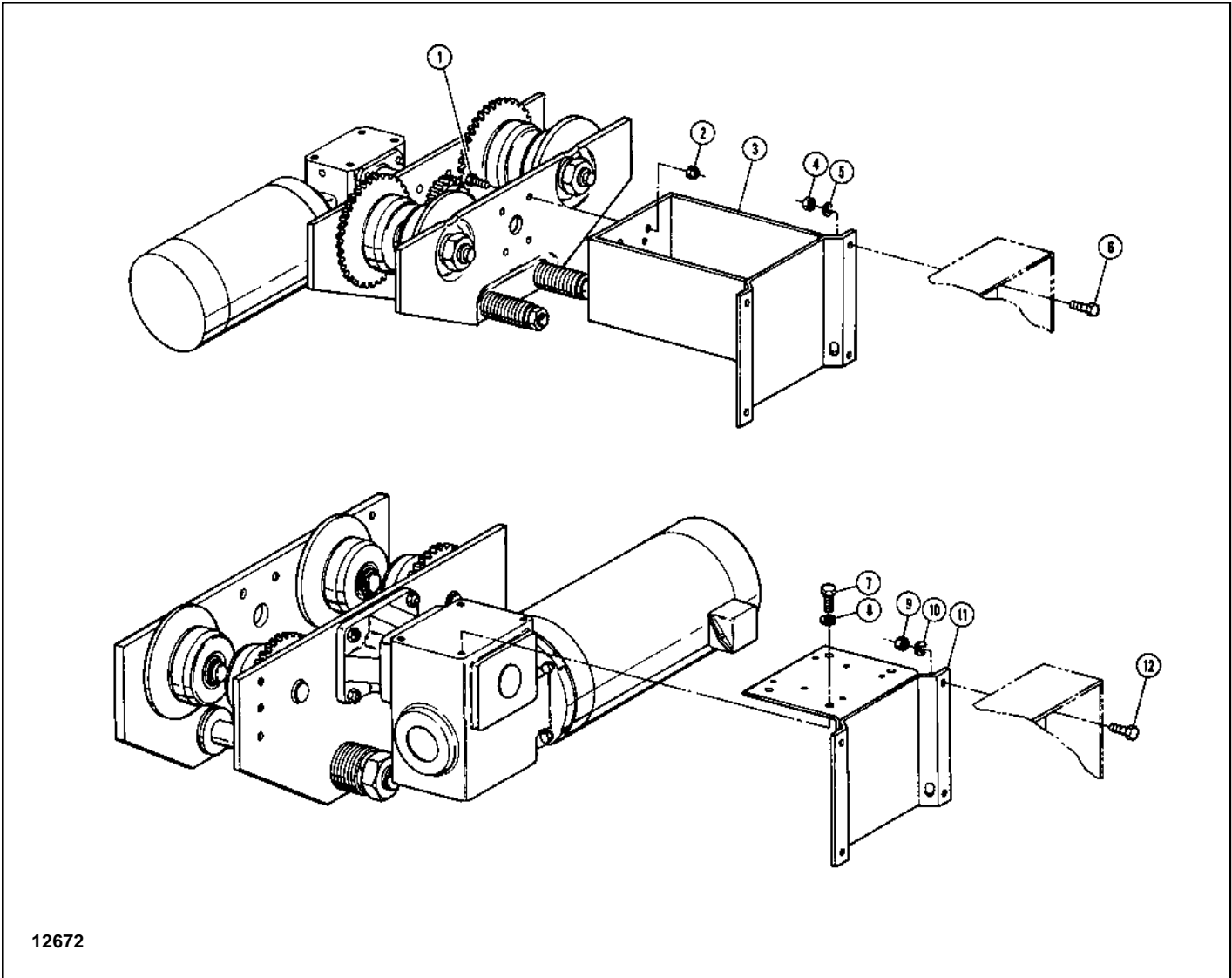

12672

Figure 11. Electrical Enclosure Mountings

Ref. No.	Part Number	Description	Qty. Req'd
		For Trolleys with 3-1/8" and 5" c/c Pins:	
1	BET-3100	Screw - Hex Cap	4
2	BET-3101	Nut - Self-locking	4
3	BET-3102	Mounting Bracket - Enclosure	1
4	BET-3103	Nut - Hex	4
5	BET-3104	Lockwasher	4
6	BET-3105	Bolt - Hex Head	4
		For Trolleys with 6" c/c Pins:	
7	BET-3106	Bolt - Hex Head	4
8	BET-3107	Lockwasher	4
9	BET-3103	Nut - Hex	4
10	BET-3104	Lockwasher	4
11	BET-3108	Mounting Bracket - Enclosure	1
12	BET-3105	Bolt - Hex Head	4

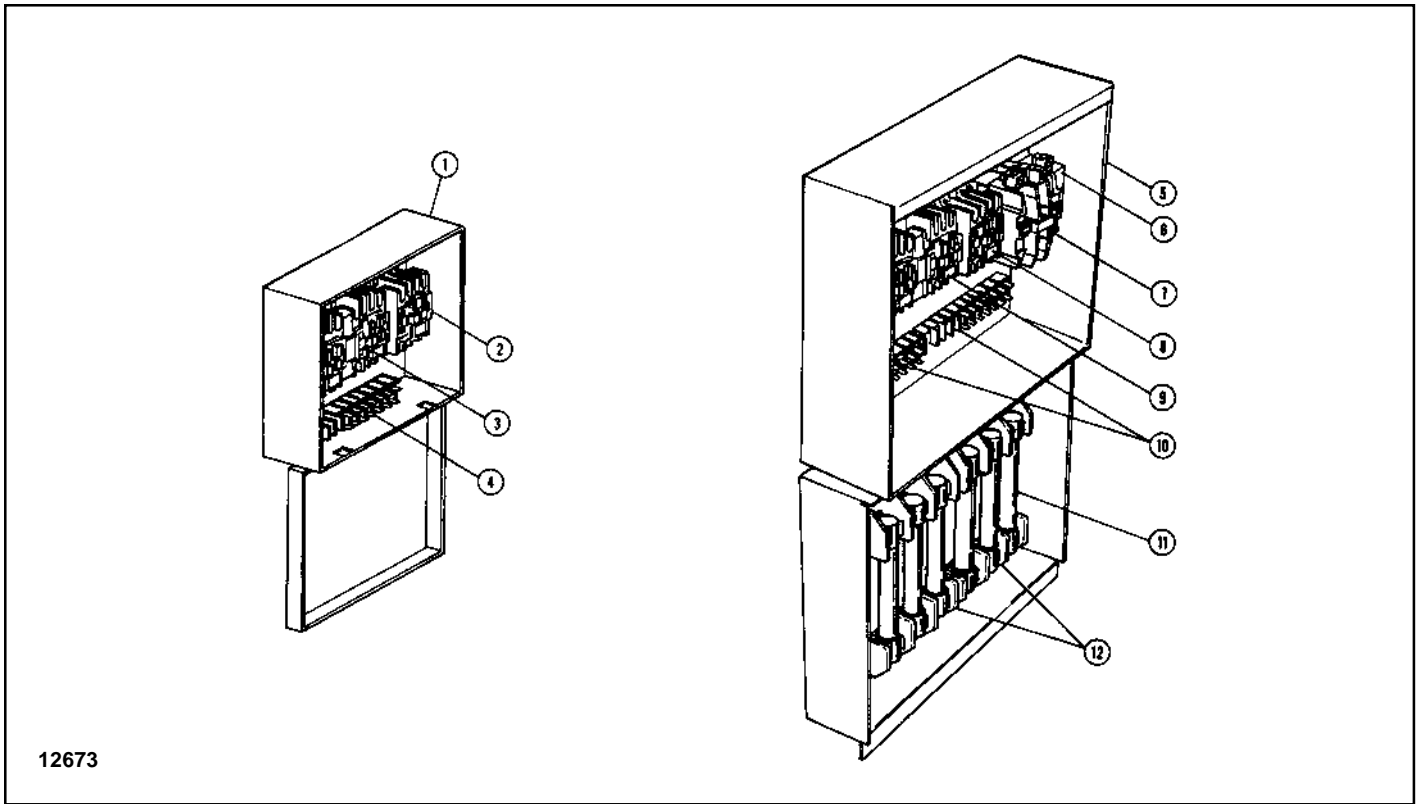
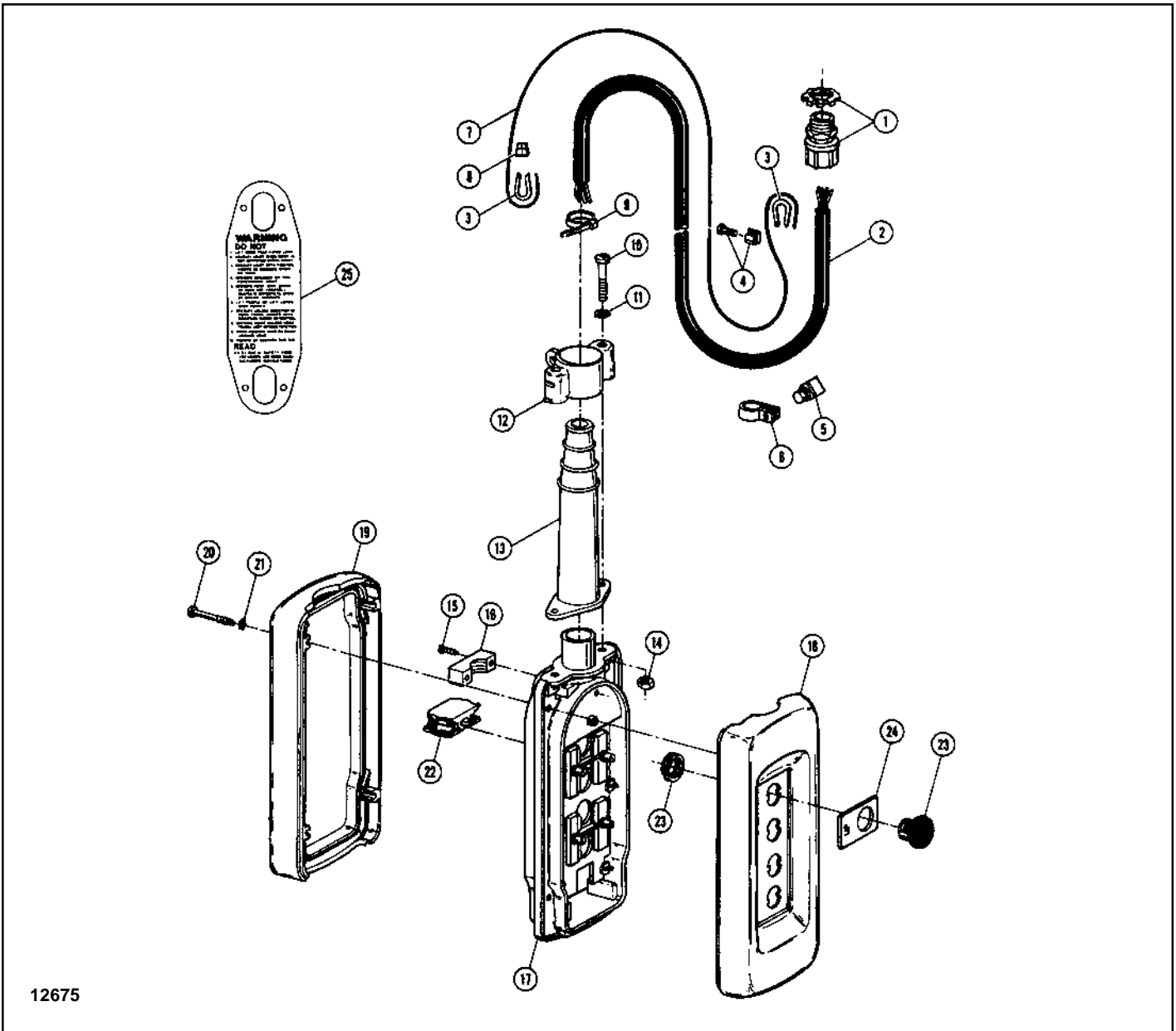

Figure 12. Electrical Enclosures

Ref. No.	Part Number	Description	Qty. Req'd
1	BET-3200	Standard Enclosure: Enclosure - Electrical	1
2	BET-3201	Contactor - Accelerating (For 2 Speeds Only) 24 Volt Control	1
	BET-3202	115 Volt Control	1
3	BET-3203	Contactor - Reversing 24 Volt Control	1
	BET-3204	115 Volt Control	1
4	BET-3205	Board - Terminal	1
5	BET-3206	Enclosure For Options:*	1
6	BET-3207	Enclosure - Electrical Transformer 208/24 Volt	1
	BET-3208	230/24 Volt or 460/24 Volt	1
	BET-3209	575/24 Volt	1
	BET-3210	208/115 Volt	1
	BET-3211	230/115 Volt or 460/115 Volt	1
	BET-3212	575/115 Volt	1
7	BET-3213	Contactor - Mainline 24 Volt Control	1
	BET-3214	115 Volt Control	1
8	BET-3201	Contactor - Accelerating 24 Volt Control	1
	BET-3202	115 Volt Control	1
9	BET-3203	Contactor - Reversing 24 Volt Control	1
	BET-3204	115 Volt Control	1

(Continued on Next Page)



12675

Figure 13. Push Button Station and Conductor Cable Assembly

Ref. No.	Part Number	Description	Qty. Req'd
1	BET-3300	Grip Assembly - Conductor	1
	BET-3301	For 6 Conductor Cable	1
	BET-3302	For 7 and 8 Conductor Cable	1
	BET-3302	For 10 and 12 Conductor Cable	1
		Cable - Flexible Conductor*	
	BET-3303	6 Conductor	1
	BET-3304	7 Conductor	1
	BET-3305	8 Conductor	1
	BET-3306	10 Conductor	1
	BET-3307	12 Conductor	1
3	BET-3308	Thimble - Strain Cable	2
4	BET-3309	Connector - Strain Cable	1
5	BET-3310	Connector - Conductor to Strain Cable	1

* Specify length required.

Figure 13. Push Button Station and Conductor Cable Assembly (Continued).

Ref. No.	Part Number	Description	Qty. Req'd
6		Clamp - Conductor	
	BET-3311	For 6 Conductor Cable	1
	BET-3312	For 7 Conductor Cable	1
	BET-3313	For 8 and 10 Conductor Cable	1
	BET-3314	For 12 Conductor Cable	1
	BET-3315	Cable - Strain*	1
	BET-3316	Sleeve - Pressure	1
	BET-3317	Push Button Station Assembly - 4 Buttons (Includes Ref. Nos. 9 thru 24)	1
	BET-3318	Push Button Station Assembly - 6 Buttons (Includes Ref. Nos. 9 thru 24)	1
	BET-3319	Enclosure Assembly - 4 Buttons (Includes Ref. Nos. 9 thru 21)	1
	BET-3320	Enclosure Assembly - 6 Buttons (Includes Ref. Nos. 9 thru 21)	1
9		Clamp - Conductor	1
10		Screw - Slotted Head	2
11		Lockwasher	2
12		Support - Strain Cable	1
13	BET-3325	Sleeve - Conductor	1
14		Nut - Hex	2
15	**	Screw - Slotted Head	2
16	**	Clamp - Conductor	1
17	**	Enclosure Body	1
18	**	Enclosure Front	1
19	**	Enclosure Rear	1
20	**	Screw - Slotted Head	
		4 Button Station	4
		6 Button Station	6
21	**	Lockwasher	
		4 Button Station	4
		6 Button Station	6
22	BET-3327	Block - Contact	
		4 Button Station	4
		6 Button Station	6
23	BET-3328	Push Button Assembly	
		4 Button Station	4
		6 Button Station	6
24		Nameplate	
	BET-3329	Up	1
	BET-3330	Down	1
	BET-3331	Right	1
	BET-3332	Left	1
	BET-3333	Start	1
	BET-3334	Stop	1
25	BET-3335	Operator Warning Label	1

* Specify length required.

** Not available separately. Order Enclosure Assembly.

Notes

Recommended Spare Parts for Your Budgit Motor Driven Trolley

Certain parts of your trolley will, in time, require replacement under normal wear conditions. It is suggested that the following parts be purchased for your trolley as spares for future use.

Motor Pinion
One Set of Wheel Bearings
One Set of Wheels
One Reversing Contactor
One Set of Fuses (If Required)

Note: When ordering parts always furnish Model and Catalog Number and Motor Nameplate Data of trolley on which the parts are to be used.

Parts for your trolley are available from your local authorized **Budgit** repair station. For the location of your nearest repair station, write:

IN USA

Yale•Lift-Tech

P.O. Box 769
Muskegon, MI 49443-0769

Phone: **800 742-9269**
Fax: **800 742-9270**

For more information contact:

American Crane & Equipment Corp.

Authorized Distributor

Tel: 877-503-2972

Fax: 484-945-0430

sales@americancrane.com

www.americancrane.com

WARRANTY

WARRANTY AND LIMITATION OF REMEDY AND LIABILITY

A. Seller warrants that its products and parts, when shipped, and its work (including installation, construction and start-up), when performed, will meet applicable specifications, will be of good quality and will be free from defects in material and workmanship. All claims for defective products or parts under this warranty must be made in writing immediately upon discovery and in any event, within one (1) year from shipment of the applicable item unless Seller specifically assumes installation, construction or start-up responsibility. All claims for defective products or parts when Seller specifically assumes installation, construction or start-up responsibility and all claims for defective work must be made in writing immediately upon discovery and in any event, within one (1) year from completion of the applicable work by Seller, provided; however, all claims for defective products and parts made in writing no later than eighteen (18) months after shipment. Defective items must be held for Seller's inspection and returned to the original f.o.b. point upon request. **THE FOREGOING IS EXPRESSLY IN LIEU OF ALL OTHER WARRANTIES WHATSOEVER, EXPRESS, IMPLIED AND STATUTORY, INCLUDING, WITHOUT LIMITATION, THE IMPLIED WARRANTIES OF MERCHANTABILITY AND FITNESS.**

B. Upon Buyer's submission of a claim as provided above and its substantiation, Seller shall at its option either (i) repair or replace its product, part or work at either the original f.o.b. point of delivery or at Seller's authorized service station nearest Buyer or (ii) refund an equitable portion of the purchase price.

C. This warranty is contingent upon Buyer's proper maintenance and care of Seller's products, and does not extend to normal wear and tear. Seller reserves the right to void warranty in event of Buyer's use of inappropriate materials in the course of repair or maintenance, or if Seller's products have been dismantled prior to submission to Seller for warranty inspection.

D. The foregoing is Seller's only obligation and Buyer's exclusive remedy for breach of warranty and is Buyer's exclusive remedy hereunder by way of breach of contract, tort, strict liability or otherwise. In no event shall Buyer be entitled to or Seller liable for incidental or consequential damages. Any action for breach of this agreement must be commenced within one (1) year after the cause of action has accrued.

BUDGIT®