

HERC-ALLOY® Chain Shortener & Rigging Hook

1000

Chain Shortener



- Quickly and easily adjust chain length of sling when the load has uneven pick points
- Painted gray for easy Grade 100 identification
- Marked with both fraction and metric sizes
- Forged alloy steel - quenched & tempered
- Mechanically attaches directly to master ring

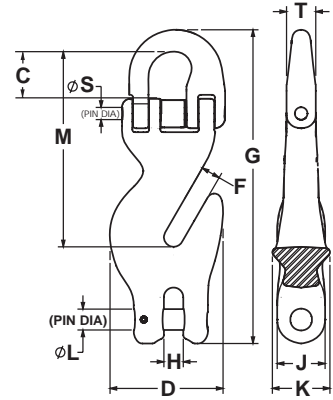

Size	Working Load Limit	Product Code	Dimensions											Weight
			C	D	G	H	J	K	L	F	M	S	T	
Imperial														
in.	lb.		in.	in.	in.	in.	in.	in.	in.	in.	in.	in.	in.	lb.
9/32	4,300	M71805A-2	0.71	2.19	5.86	0.38	0.80	1.00	0.36	0.38	3.38	0.21	0.50	1.20
3/8	8,800	M71806A-2	1.16	2.74	7.61	0.47	1.16	1.40	0.51	0.47	4.74	0.31	0.71	2.50
1/2	15,000	M71808A-2	1.43	3.34	9.36	0.65	1.37	2.08	0.63	0.65	5.82	0.41	0.86	4.80
5/8	22,600	M71810A-2	1.74	4.19	11.56	0.79	1.53	2.47	0.75	0.79	7.04	0.48	1.06	8.20

Rigging Hook



- Large eye to easily accommodate other G100 fittings
- Quench & tempered alloy steel
- Painted grey for easy identification

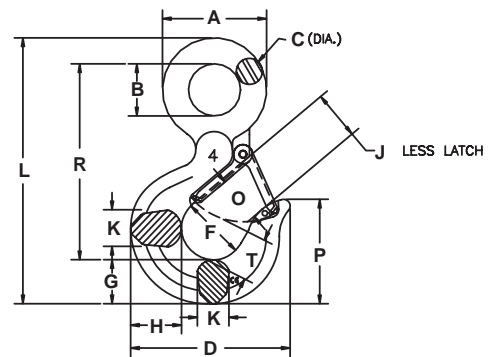

Size	Working Load Limit	Product Code w/ latch	Product Code w/o latch	Dimensions													Weight	
				A	B	C	D	F	G	H	J	K	L	O	P	R		T
Imperial																		
in.	lb.			in.	in.	in.	in.	in.	in.	in.	in.	in.	in.	in.	in.	in.	in.	lb.
7/32	2,700	M7502A	M7402A	1.50	0.75	0.38	3.06	1.25	0.87	1.05	0.93	0.63	4.37	0.93	2.12	3.13	0.87	0.66
9/32	4,300	M7503A	M7403A	1.75	0.88	0.44	3.33	1.38	0.94	1.11	0.97	0.71	5.04	0.97	2.27	3.66	0.97	1.12
5/16	5,700	M7504A	M7404A	2.13	1.13	0.50	3.67	1.50	1.06	1.21	1.06	0.88	5.63	1.06	2.54	4.09	1.03	1.46
3/8	8,800	M7505A	M7405A	2.50	1.25	0.63	4.20	1.63	1.27	1.43	1.19	0.94	6.55	1.16	2.80	4.67	1.16	2.42
1/2	15,000	M7507A	M7407A	3.06	1.56	0.75	5.11	2.00	1.44	1.63	1.50	1.31	7.97	1.41	3.47	5.78	1.53	4.10
5/8	22,600	M7509A	M7409A	3.88	2.00	0.94	6.24	2.50	1.82	2.01	1.78	1.68	10.07	1.69	4.59	7.31	1.94	8.16