

# Top Running Trolley

## 30 TON CAPACITY

### PRODUCT INFORMATION

DWG. NO:

# NOR30b26

DATE: 07/27/2016

REVISION: 1

TYPE: 26

### 4 PART SINGLE REEVING

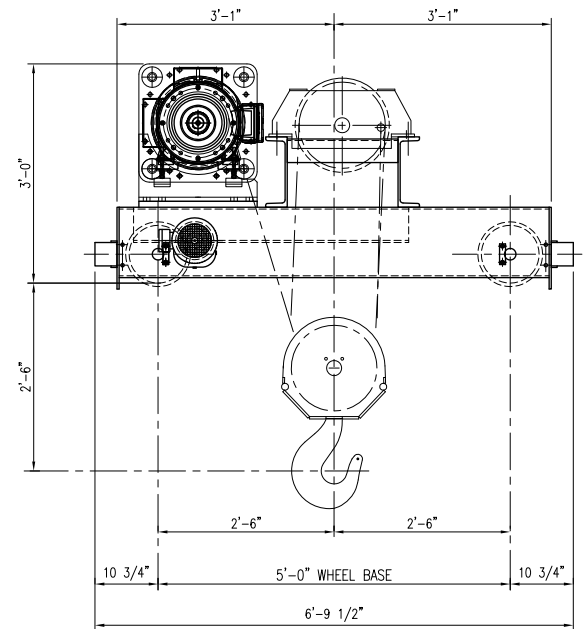
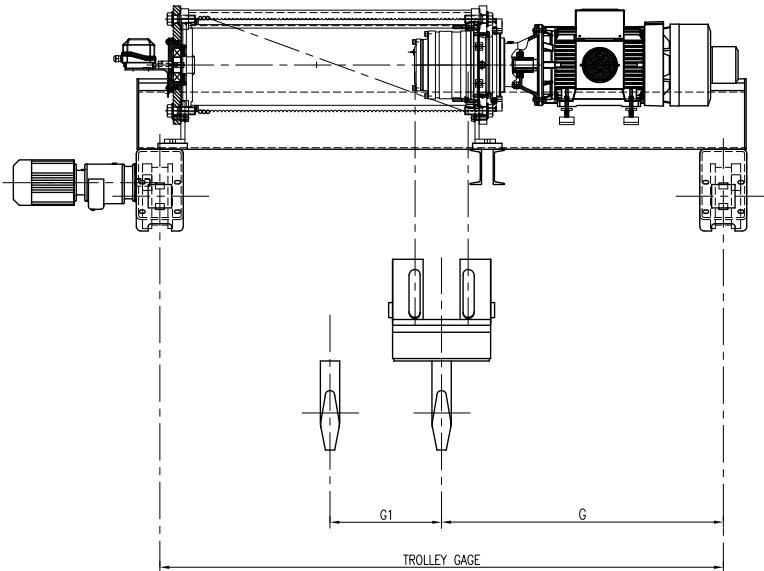

WIRE ROPE  $\frac{7}{8}$ " 6 x 36 IWRC EEIP

ACECO RESERVES THE RIGHT TO MAKE CHANGES WITHOUT NOTICE.

### HOIST TECHNICAL DATA

CLASS	CMAA CLASS "D"	TROLLEY SPEED	MOTOR DATA	Optional: Hoisting Speed, Trolley Speed, Lift, etc.; consult factory. DRUM DIA. 24" WHEEL DIA. 12"
POWER SUPPLY	460V-3PH-60HZ	60 F.P.M.	X HP / 1800 RPM	
		70 F.P.M.	X HP / 1800 RPM	
		90 F.P.M.	X HP / 1800 RPM	

### DIMENSIONAL INFORMATION

HOIST SIZE	HEIGHT OF LIFT FEET	TROLLEY GAGE	G	G1	WEIGHT LBS.
3'	21	5' - 0"	27"	7"	7,000
4'	40	6' - 6"	33"	11"	7,600
5'	61	7' - 0"	36"	13"	8,200
6'	78	7' - 6"	39"	14"	8,500
7'	97	8' - 0"	41"	16"	9,000
8'	116	10' - 6"	53"	19"	10,500

HOIST MOTOR	SPEED	SPEED
HP/RPM	VARIABLE	SWIFT LIFT
TEFC, S3 - 40% CLASS F INSULATION	FPM	FPM
40 / 1800	19	24