

# CM SERIES 633 TROLLEY INSTALLATION INSTRUCTIONS

## **⚠ WARNING**

IMPROPER INSTALLATION AND/OR OPERATION CAN RESULT IN THE TROLLEY COMING OFF OF BEAM.

TO AVOID BODILY INJURY AND PROPERTY DAMAGE:

- DO INSTALL TROLLEY AS DIRECTED HEREIN.
- DO MAKE CERTAIN END STOPS RESTRAIN TROLLEY.
- DO NOT USE TO LIFT OR TRANSPORT PEOPLE.
- DO NOT USE TO SUSPEND LOADS OVER PEOPLE.
- DO NOT OVERLOAD.
- DO NOT SIDE LOAD.

### GENERAL

After removing the Series 633 Trolley from the shipping carton, inspect the various parts for damage which may have occurred during shipment or handling. All trolleys consist of two side frame/trackwheel assemblies, an equalizer pin, 4 equalizer pin nuts, 2 equalizer pin spacers, one suspension plate and a number of spacer washers. If shipping damage has occurred, refer to the packing list envelope on the carton for claim procedure.

### ADJUSTMENT

The Series 633 Trolleys are adjustable for operation on a wide range of beam flange (either sloped or flat) widths by arranging the spacer washers. To determine the arrangement of the spacer washers, measure the flange width on which the trolley is to be installed. Scales are provided on the back of this instruction sheet to aid in measuring the flange width.

### INSTALLATION

Using the measurement of the beam flange width, determine the arrangement of the spacer washers using the chart on the back of this sheet. Loosely assemble the side frame assemblies, equalizer pin, suspension plate, spacers, spacer washers and equalizer pin nuts as shown. On the 1/2 through 3-ton trolleys there must be at least one spacer washer on the inside and the outside of each side frame. On the 5-ton trolley, there must be at least two spacer washers on the outside of each side frame and at least one spacer washer on the inside of each side frame.

**NOTE:** The number of spacer washers indicated in the chart is nominally correct.

However, due to the variations in size encountered in structural steel sections, it may be necessary to vary the number of washers used. Also, the distance between the trackwheel flanges (distance "X") should be 1/8 to 3/16 inch greater than the beam flange width for straight runway beams, and 3/16 to 1/4 inch greater than the beam flange width if the runway system includes sharp curves. When used on runway beams with curves, lightly lubricate the edges of the beam at the curved sections with grease.

Install the trolley on the beam by sliding one side frame out far enough to allow the trackwheels to clear the beam flange. Lift the trolley up so that the trackwheels are riding on the beam and draw the side frames together and tighten the inside nuts on each side of the trolley snugly. Apply a light load to the suspension plate to ensure that all four trackwheels contact the beam flange. Then tighten the inside nuts firmly and secure them by firmly tightening the outside nuts to lock the nuts in position.

**NOTE:** Metric tools required to tighten equalizer pin nuts.

### CM REPLACEMENT POLICY

If any properly maintained CM part, within 1 year of shipment, proves to have been originally defective in materials or workmanship; and is returned to us, transportation prepaid, we will replace or repair the part, no charge, f.o.b. our factory.

We reserve the right to change materials or design, if in our opinion, such changes will improve our product. Abuse, repair by an unauthorized person, or use of non-CM replacement parts voids the guarantee and could lead to dangerous operation. For full Terms of Sale, see Sales Order Acknowledgement. Also refer to the back of this instruction sheet for limitations of warranties, remedies and damages and, indemnification and safe operation.

## **⚠ WARNING**

TO AVOID INJURY AND/OR PROPERTY DAMAGE:

1. The load should be directly under the trolley. Avoid off center loading of any kind. Side loading may spread the side frames, bend the suspension plate and thus create an accident. Read installation instructions and ASME B30.11 before operating the trolley.
2. Deviation from the CM washer spacing recommendations can cause the trolley to fall from the beam.
3. The trolley and beam should be inspected periodically to assure their continued operation. Using a damaged or malfunctioning trolley or operating the trolley on a beam with an excessively worn flange may cause the trolley to fall from the beam.
4. The equalizer pin nuts must be tight and locked in position and, they should be periodically checked to make sure they are tight. If the nuts are loose, the side frames will spread and allow the trolley to fall from the beam.
5. To keep the suspension plate and load centered, the spacer washers at "B" and "C" (refer to chart) must be the same or differ by only one washer. If this spacing is not maintained, there will be unequal loading on the trolley and the beam and as a result, the side frames may bend and allow the trolley to fall from the beam.
6. The use of materials or replacement parts other than CM manufacture may lead to dangerous operation.

# CM SERIES 633 PLAIN TROLLEY

## \*CHART FOR ARRANGEMENT OF SPACER WASHERS

S-BEAM FLANGE WIDTH INCHES (MM)	1/2 TON				1 TON				2 TON				3 TON				5 TON			
	A	B	C	D	A	B	C	D	A	B	C	D	A	B	C	D	A	B	C	D
2-1/2 (63.5)	22	1	1	23																
2-5/8 (66.7)	22	1	1	23																
2-3/4 (69.8)	21	2	2	22																
3 (76.2)	20	3	4	20	22	3	3	23												
3-3/8 (85.7)	17	6	6	18	21	4	5	21												
3-5/8 (92.1)	16	8	7	16	20	5	6	20	19	1	1	20								
4 (101.6)	14	10	10	13	19	7	7	18	17	3	3	18	17	1	1	18				
4-1/8 (104.8)	13	11	10	13	18	8	7	18	17	3	4	17	17	1	1	18				
4-5/8 (117.5)	10	14	14	9	16	9	10	16	15	5	6	15	15	3	4	15	16	1	2	16
5 (127.0)	7	16	16	8	15	11	11	14	13	7	7	14	14	5	5	13	14	3	3	15
5-1/8 (130.2)	7	17	17	6	13	12	12	14	13	7	8	13	13	5	6	13	14	3	4	14
5-1/4 (133.4)	6	18	18	5	13	13	12	13	12	8	8	13	12	6	6	13	13	4	4	14
5-1/2 (139.7)	4	19	20	4	12	13	14	12	11	9	9	12	11	7	7	12	12	5	5	13
5-5/8 (142.9)	3	20	21	3	11	14	14	12	11	9	10	11	11	7	8	11	12	5	6	12
6 (152.4)					10	15	16	10	9	11	12	9	10	9	9	9	10	7	7	11
6-1/4 (158.8)					9	16	17	9	8	12	13	8	9	10	10	8	9	8	8	10
6-3/8 (161.9)					8	17	17	9	7	13	13	8	8	11	10	8	9	8	9	9
7 (177.8)					6	19	20	6	5	15	16	5	5	13	14	5	6	11	12	6
7-1/8 (181.0)					5	20	20	6	4	16	16	5	4	14	14	5	5	12	12	6
7-1/4 (184.2)					4	21	21	5	4	16	17	4	4	14	15	4	5	12	13	5
7-7/8 (200.0)					2	23	24	2	1	19	19	2	2	17	17	1	2	15	15	3
8 (203.2)					1	24	24	2	1	19	20	1	1	18	17	1	2	15	16	2

\*The use of other than CM supplied spacer washers may result in trackwheel to beam flange variations and thus the above chart will not apply.

### OPERATION

1. Observe trolley load capacity. Do not overload.
2. Place load directly under trolley. Avoid off-center and side loading of any kind.
3. Read the instructions contained on this sheet as well as \*ASME B30.11 and the manual provided with the hoist or other appliance used with this trolley.

### WARNING

TROLLEY MAY FALL FROM BEAM IF IMPROPERLY OPERATED

TO AVOID INJURY:

- DO NOT OVERLOAD
- DO NOT SIDE LOAD
- DO NOT USE TO LIFT OR TRANSPORT PEOPLE, OR SUSPEND LOADS OVER PEOPLE.

\*Obtainable from ASME order department, 22 Law Drive, Box 2300, Fairfield, NJ 07007-2300, U.S.A.

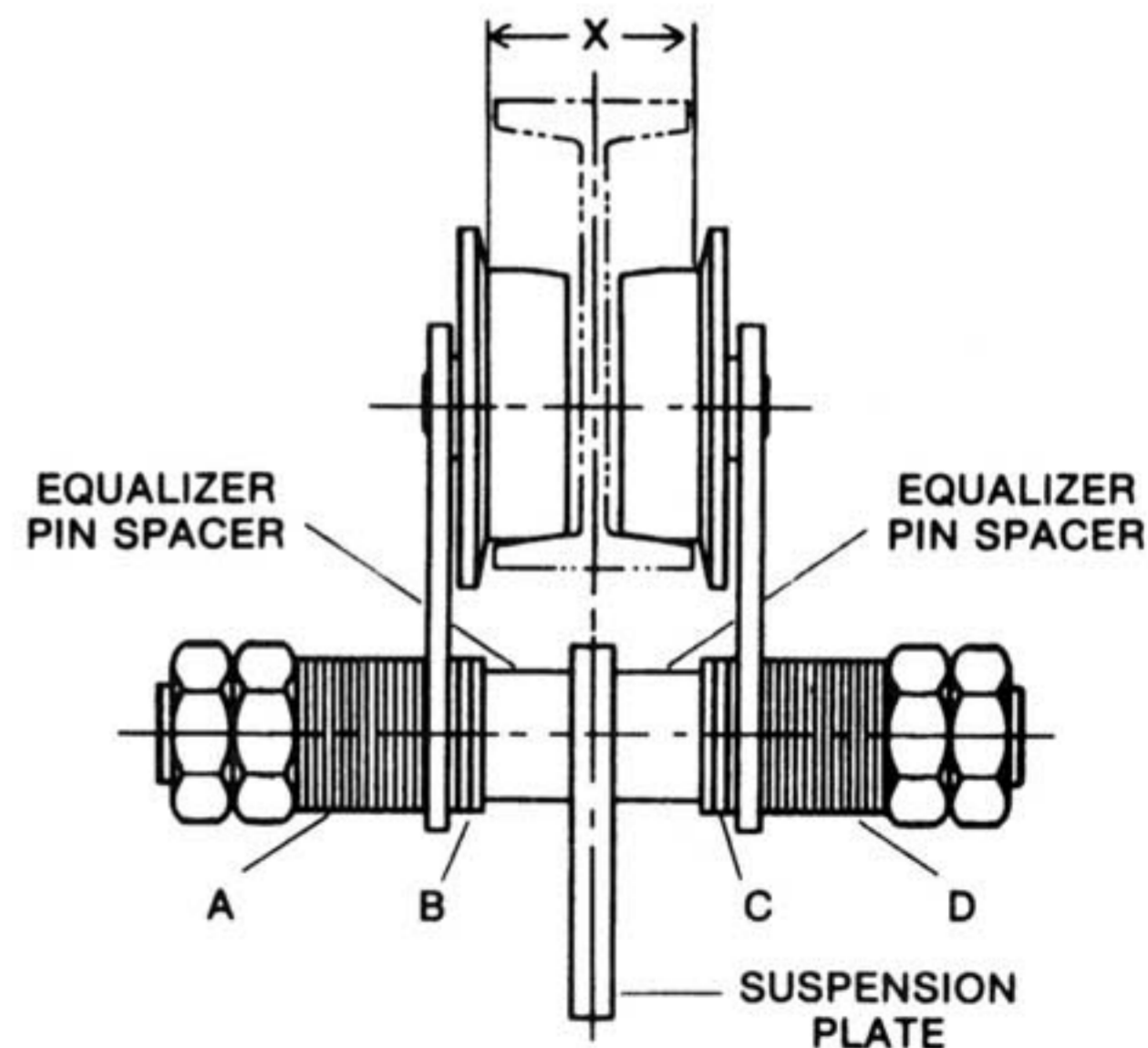

## INSPECTION

Periodic inspection of the trolley should be conducted at the same time the hoist (or other appliance) is inspected. As a minimum, a monthly inspection of the suspension plate, trackwheels and equalizer pin nuts should be carried out.

Measure the depth of the section at the upper and lower portions of the suspension plate. If either is less than that indicated below, the suspension plate must be replaced.

### Suspension Plate

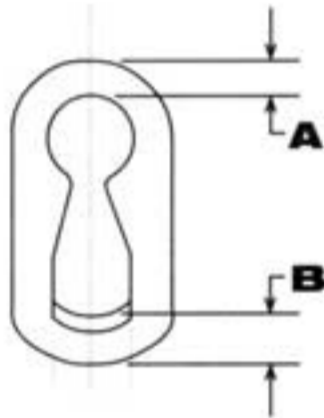

Rated Load Tons (kg.)	Replace Suspension Plate If A or B are less than:	
	A In. (mm)	B In. (mm)
1/2 (500)	.43 (11.0)	.55 (14)
1 (1000)	.47 (11.9)	.54 (13.9)
2 (2000)	.59 (15.1)	.74 (18.9)
3 (3000)	.93 (23.6)	1.25 (31.9)
5 (5000)	1.27 (32.2)	1.24 (31.5)

Side frame assemblies should be replaced if the trackwheels are loose on the stud, have indications of cracks on tread or flange or if there is excess wear on tread or flange.

Check equalizer pin nuts for tightness and make sure they are firmly tightened against each other.

## Series 633 Plain Trolley 1/2, 1, 2, 3 and 5 Ton Capacities

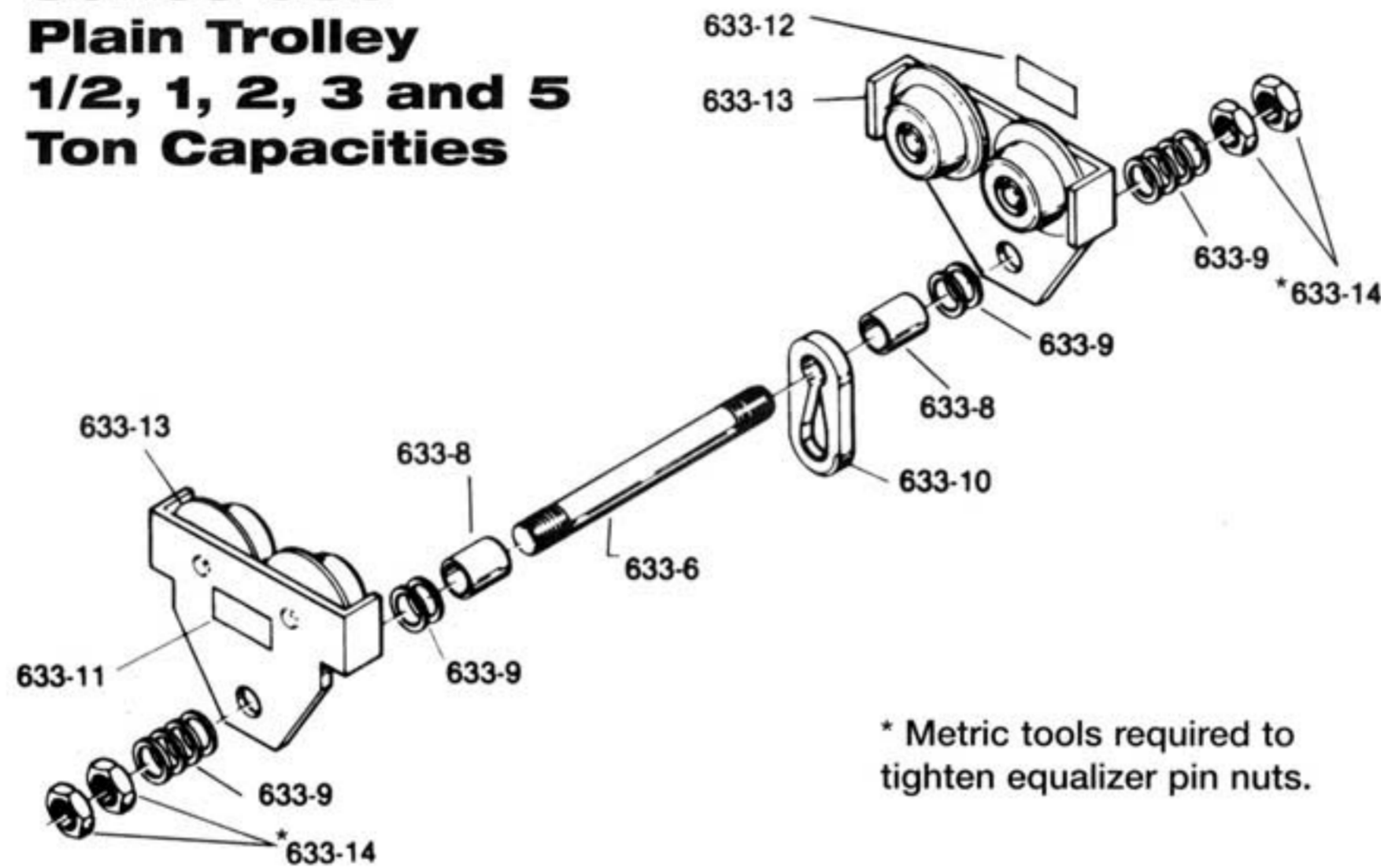

\* Metric tools required to tighten equalizer pin nuts.

Series 633 Trolley Parts List							
Key No.	No. Req'd.	Part Name	Part Number				
			1/2 Ton (500 kg.)	1 Ton (1000 kg.)	2 Ton (2000 kg.)	3 Ton (3000 kg.)	5 Ton (5000 kg.)
633-6	1	Equalizer Pin	33777	33746	33753	33760	33767
633-8	2	Equalizer Pin Spacer	33741	33748	33755	33762	33769
633-9	—	Spacer Washer	33742 (47 Req'd.)	33749 (51 Req'd.)	33756 (41 Req'd.)	33763 (37 Req'd.)	33770 (35 Req'd.)
633-10	1	Suspension Plate	33743	33750	33757	33764	33771
633-11	1	Identification Label	33720	33721	33722	33723	33724
633-12	1	Warning Label	33779	33779	33779	33779	33779
633-13	2	Side Frame Assembly (Includes Trackwheels)	33744	33751	33758	33765	33772
633-14	4	Equalizer Pin Nut	33778	33747	33754	33761	33768

## REPLACEMENT PARTS

### ORDERING INSTRUCTIONS

The following information must accompany all correspondence or repair parts orders.

- 1) Capacity of trolley from nameplate
- 2) Serial number of trolley-2 letters stamped on the identification plate.

For parts orders also specify:

- 1) Quantity desired
- 2) Key number or part
- 3) Part name
- 4) Part number

Parts should be ordered from CM's authorized Master Parts Depot conveniently located throughout the United States and Canada. Refer to the back of this instruction sheet to locate the Master Parts Depot nearest you.

### WARNING

Using "commercial" or other manufacturer's parts to repair the Series 633 Trolley may cause load loss.

### TO AVOID INJURY:

Order all replacement parts from CM. Some parts may look alike but often CM parts are made of specific materials or processed to achieve specific properties.



MILLIMETERS

#### LIMITATION OF WARRANTIES, REMEDIES AND DAMAGES

THE WARRANTY STATED BELOW IS GIVEN IN PLACE OF ALL OTHER WARRANTIES, EXPRESS OR IMPLIED, OF MERCHANTABILITY, FITNESS FOR A PARTICULAR PURPOSE, OR OTHERWISE, NO PROMISE OR AFFIRMATION OF FACT MADE BY ANY AGENT OR REPRESENTATIVE OF SELLER SHALL CONSTITUTE A WARRANTY BY SELLER OR GIVE RISE TO ANY LIABILITY OR OBLIGATION.

Seller warrants that on the date of its delivery to carrier the goods are free from defects in workmanship and materials.

SELLER'S SOLE OBLIGATION IN THE EVENT OF BREACH OF WARRANTY OR CONTRACT OR FOR NEGLIGENCE OR OTHERWISE WITH RESPECT TO GOODS SOLD SHALL BE EXCLUSIVELY LIMITED TO REPAIR OR REPLACEMENT, F.O.B. SELLER'S POINT OF SHIPMENT, OF ANY PARTS WHICH SELLER DETERMINES TO HAVE BEEN DEFECTIVE or if Seller determines that such repair or replacement is not feasible, to a refund of the purchase price upon return of the goods to Seller.

Any action against Seller for breach of warranty, negligence or otherwise must be commenced within one year after such cause of action accrues.

NO CLAIM AGAINST SELLER FOR ANY DEFECT IN THE GOODS SHALL BE VALID OR ENFORCEABLE UNLESS BUYER'S WRITTEN NOTICE THEREOF IS RECEIVED BY SELLER WITHIN ONE YEAR FROM THE DATE OF SHIPMENT.

For more information contact:  
American Crane & Equipment Corp.  
Authorized Distributor  
Tel: 877-503-2972  
Fax: 484-945-0430  
sales@americancrane.com  
www.americancrane.com

Seller shall not be liable for any damage, injury or loss arising out of the use of the goods if, prior to such damage, injury or loss, such goods are (1) damaged or misused following Seller's delivery to carrier; (2) not maintained, inspected, or used in compliance with applicable law and Seller's written instructions and recommendations; or (3) installed, repaired, altered or modified without compliance with such law, instructions or recommendations.

UNDER NO CIRCUMSTANCES SHALL SELLER BE LIABLE FOR INCIDENTAL OR CONSEQUENTIAL DAMAGES AS THOSE TERMS ARE DEFINED IN SECTION 2-715 OF THE UNIFORM COMMERCIAL CODE.

#### INDEMNIFICATION AND SAFE OPERATION

Buyer shall comply with and require its employees to comply with directions set forth in instructions and manuals furnished by Seller and shall use and require its employees to follow such instructions and manuals and to use reasonable care in the use and maintenance of the goods. Buyer shall not remove or permit anyone to remove any warning or instruction signs on the goods. In the event of personal injury or damage to property or business arising from the use of the goods, Buyer shall within 48 hours thereafter give Seller written notice of such injury or damage, Buyer shall cooperate with Seller in investigating any such injury or damage and in the defense of any claims arising therefrom.

If Buyer fails to comply with this section or if any injury or damage is caused, in whole or in part, by Buyer's failure to comply with applicable federal or state safety requirements, Buyer shall indemnify and hold Seller harmless against any claims, loss or expense for injury or damage arising from the use of the goods.