

SHAW-BOX[®]

INSTALLATION INSTRUCTIONS AND PARTS LIST FOR SHAW-BOX[®] WIRE ROPE GUIDE FOR SERIES 800 HOST

THE INFORMATION CONTAINED IN THIS MANUAL IS FOR INFORMATIONAL PURPOSES ONLY AND YALE•LIFT -TECH, DOES NOT WARRANT OR OTHERWISE GUARANTEE (IMPLIEDLY OR EXPRESSLY) ANYTHING OTHER THAN THE COMPONENTS THAT YALE•LIFT-TECH MANUFACTURES AND ASSUMES NO LEGAL RESPONSIBILITY (INCLUDING, BUT NOT LIMITED TO CONSEQUENTIAL DAMAGES) FOR INFORMATION CONTAINED IN THIS MANUAL.

WARNING

Side pulling and operation without limits may result in destruction of the rope guide with resultant falling parts.

TO AVOID INJURY AND PROPERTY DAMAGE:

- Do not side pull.
- Do not operate hoist without properly set upper and lower screw type limit switches.

GENERAL

The rope guide is designed to prevent the hoisting rope on single reeved Shaw-Box Series 800 Hoists from skipping grooves when the rope goes slack.

Observe all cautions and warnings given in the hoist Operation, Service & Parts Manual.

INSTALLATION INSTRUCTIONS

If the rope guide is being installed at the same time as the hoist, it is recommended that the rope guide be installed after reeving the hoist but before testing the hoist; so that the rope guide function may be checked as the hoist is tested.

See Figure 1.

- a. Unbolt guide ring halves. Apply grease (included) generously to the area that fits in the rope drum grooves.
- b. Place ring halves around rope drum so that:
 1. Rope coming off drum passes through slot in slotted half of ring.
 2. Ridges in rope guide fit in rope grooves on drum.
 3. Boss (for bolting) on non-slotted rope guide half is toward outside of hoist.
- c. Using button head cap screws, washers and lockwashers bolt guide ring halves together.
- d. Check rotation of guide on rope drum. Guide should freely rotate, without binding. Adjust if necessary.
- e. Attach rollers to rotation restraint with washers, lockwashers and nuts.
- f. Using button head cap screws, washers and lockwashers bolt rotation restraint to rope guide. Position restraint so that rollers will contact the side and bottom of the horizontal plate across bottom of the hoist frame, with approximately 1/8" of play.
- g. Adjust upper and lower limits of the screw type limit switch so that hoisting and lowering will be halted before the rope guide reaches either end of the rope drum.
- h. If hoist is being installed, perform load test as required. Otherwise, test operation of rope guide only. Rope guide should travel smoothly on drum without binding. Rope should exit drum through slot in rope guide with minimum contact with guide.

MAINTENANCE

The rope guide should be removed, inspected and regreased (MOBILTAC 275 NC) on a regular basis. If the rope guide shows major wear or any damage; replace. Replace rope guide when wire rope is replaced.

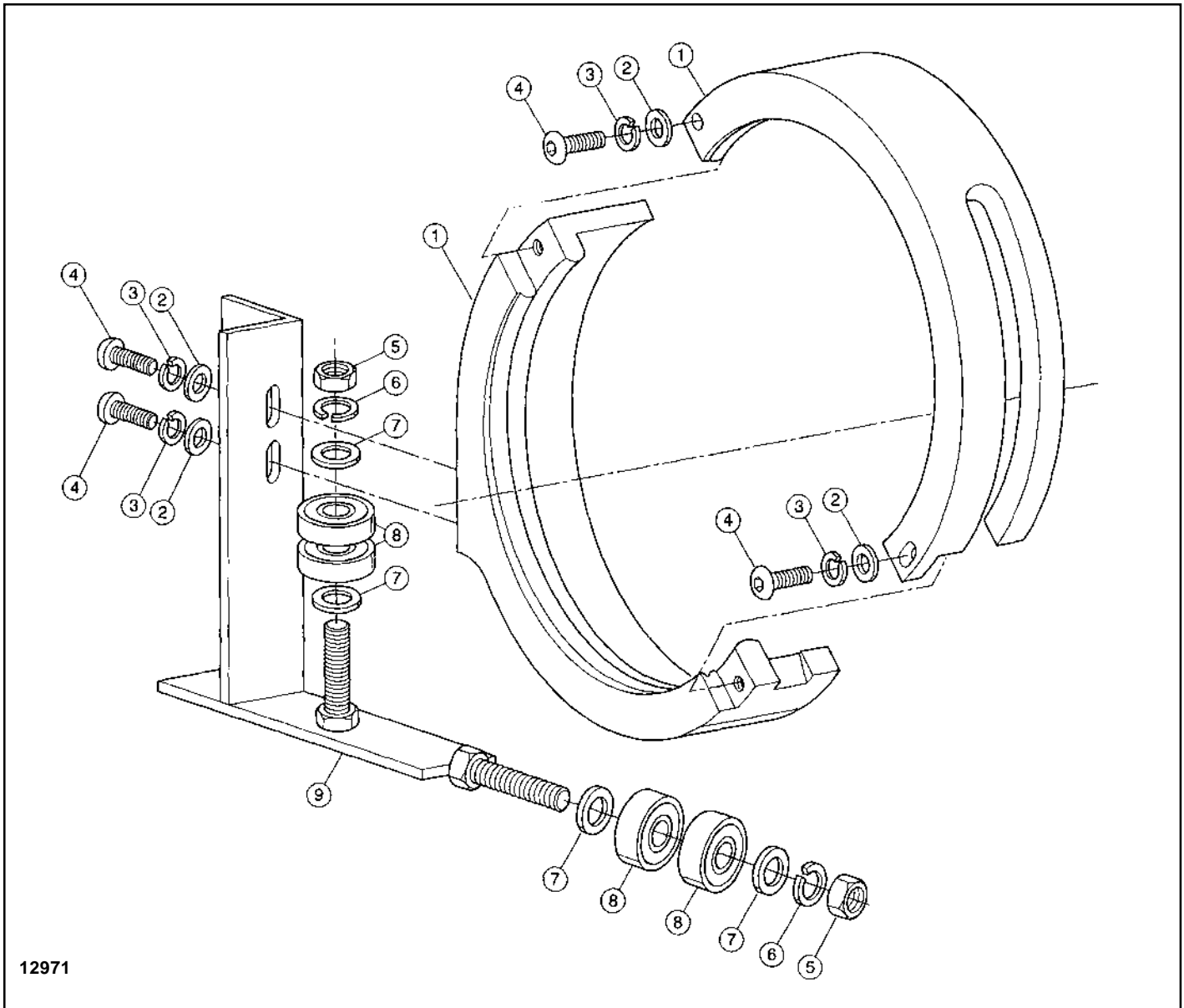

12971

Figure 1.

Ref. No.	Part Number	Description	Qty. Req'd
		Rope Guide Assembly (Includes Ref Nos. 1 thru 9)	1
1	800-9000	For 3/16" Wire Rope	
	800-9001	For 1/4" Wire Rope	
	800-9002	For 5/16" Wire Rope	
		Guide Ring Assembly	1
2	800-9003	For 3/16" Wire Rope	
	800-9004	For 1/4" Wire Rope	
	800-9005	For 5/16" Wire Rope	
2	800-9006	Standard Washer (1/4)	4
3	800-9007	Lockwasher (1/4)	4
4	800-9008	Button Head Cap Screw (1/4-20 x 5/8)	4
5	800-9009	Hex Nut (M12 x 1.75mm)	2
6	800-9010	Lockwasher (7/16)	2
7	800-9011	Flat Washer (7/16)	4
8	800-9012	Rollers	4
9	800-9013	Rotation Restraint Weldment	1