

**OPERATING,
MAINTENANCE
& PARTS
MANUAL**

**AIR
CHAIN HOIST**

For more information contact:
American Crane & Equipment Corp.
Authorized Distributor
Tel: 877-503-2972
Fax: 484-945-0430
sales@americancrane.com
www.americancrane.com



XL AIR CHAIN HOIST

Before installing hoist, fill in the information below. Refer to the hoist identification plate.

Model No. _____

Serial No. _____

Purchase Date _____

Rated Capacity _____

Rated capacities 2 through 7½ tons/
2000 through 7500 kg

Follow all instructions and warnings for inspecting, maintaining and operating this hoist.

The use of any hoist presents some risk of personal injury or property damage. That risk is greatly increased if proper instructions and warnings are not followed. Before using this hoist, each operator should become thoroughly familiar with all warnings, instructions and recommendations in this manual.

Retain this manual for future reference and use.

Forward this manual to operator.
Failure to operate equipment as directed in manual may cause injury.

XL HOIST PARTS AND SERVICES ARE AVAILABLE IN THE UNITED STATES AND IN CANADA

As a XL Hoist user, you are assured of reliable repair and parts services through a network of Master Parts Depots and Service Centers that are strategically located in the United States and Canada. These facilities have been selected on the basis of their demonstrated ability to handle all parts and repair requirements promptly and efficiently.

Below is a list of the Master Parts Depots in the United States and Canada. To quickly obtain the name of the U.S. Service Center located nearest you, call (800) 888-0985. Fax: (716) 689-5644. In the following list, the Canadian Service Centers are indicated.

UNITED STATES MASTER PARTS DEPOT	CANADIAN SERVICE CENTERS
ARKANSAS YALE HOISTS P.O. Box 1000 3105 North Washington Forest City Ar 72335 800/999-6318 Fax 800/766-0223	ALBERTA **COLUMBUS McKINNON, LTD. 10311-174th Street Edmonton, Alberta T8H 1N3
CALIFORNIA OTTO SYSTEMS, INC. 12010 Bloomfield Ave. Santa Fe Springs, CA 90670 562/462-1612 or 800/596-7392 Fax 562/462-1617 or 7656 Las Positas Road Livermore, CA 94551-8203 925/245-8800 or 800/508-6886 Fax 925/245-8804	NOVA SCOTIA *W & A MOIR 95 Ilsley Ave. Dartmouth, Nova Scotia B3B 1L5 902/468-7720 Fax 902/468-3777
COLORADO MATERIALS HANDLING EQUIPMENT CO. 1740 W. 13th Ave. Denver, CO 80204 303/573-5333 or 800/873-5333 Fax 303/893-3854	ONTARIO *R & W HOIST REPAIR, LTD. 790 Redwood Square Units 5, 6, & 7 Oakville, Ontario L6L 6N3 905/825-5500 Fax 905/825-5315
GEORGIA ACE INDUSTRIES, INC. 6295 McDonough Drive Norcross, GA 30093 770/441-0898 or 800/733-2231 Fax 770/441-0326	*TORONTO ELECTRIC HOIST SALES & SERVICE 72 Crockford Blvd. Scarborough, Ontario M1R 3C4 416/755-7716 Fax 800/461-0290
ILLINOIS CM CHICAGO PARTS & SERVICE 7747 West Van Buren Street Forest Park, IL 60130 877/511-3170 Fax 708/771-7326	*MASLACK SUPPLY, LTD. 488 Falconbridge Road Sudbury, Ontario P3A 4S4 705/566-1270 Fax 705/566-4208
INDIANA HORNER ELECTRIC COMPANY, INC. 1521 East Washington Street Indianapolis, IN 46201 317/639-4261 Fax 317/639-4344	*COLUMBUS McKINNON, LTD. P.O. Box 1106 10 Brook Road, North Cobourg, Ontario K9A 4W5 905/372-0153 Fax 905/372-3078
IOWA VMI HOIST & CRANE SERVICES 901 17TH Street NE Cedar Rapids, IA 52406 319/365-4662 Fax 319/365-8075	QUEBEC *HERCULES SLING & CABLE 2525 Louis A. Amos Lachine, Quebec H8T 1C3 514/631-5511 Fax 514/636-1084
KANSAS INDENPENDENT ELECTRIC MACHINERY 4425 Oliver Street Kansas City, KS 66106 913/362-1155 Fax 913/904-3330	*LEGER HOIST EQUIPMENT CO. 7995-17th Ave. Montreal, Quebec H1Z 3R2 514/376-3050 Fax 514/376-0657
LOUISIANA BEERMAN PRECISION, INC. 4206 Howard Ave. New Orleans, LA 70125 504/486-9391 Fax 504/486-7482	*ARE ALSO MASTER PARTS DEPOTS **MASTER PARTS DEPOT ONLY
MASSACHUSETTS ABEL DISTRIBUTORS, INC. 50 Parker Street, Unit 2 Newburyport, MA 01950 978/463-0700 Fax 978/463-5200	HYDRAULIC EQUIPMENT SERVICES, INC. 1021 North San Jacinto Street Houston, TX 77002 713/228-9601 Fax 713/228-0931
MICHIGAN LIFT-TECH INTERNATIONAL P.O. Box 769 414 West Broadway Avenue Muskegon, MI 49443-0769 800/742-9269 or 800/742-9270	WISCONSIN TRESTER HOIST & EQUIPMENT, INC. W136 N4863 Campbell Drive Menomonee Falls, WI 53051 262/790-0700 or 800/234-6098 Fax 262/790-1009
NEW JERSEY SHUPPER-BRICKLE EQUIPMENT CO. 2394 Route 130, Suite C Dayton, NJ 08810 732/438-3888 Fax 732/438-3889	
NEW YORK VOLLAND ELECTRIC EQUIPMENT CO. 75 Innsbruck Drive Buffalo, NY 14227 716/656-9900 Fax 716/656-8898/8899	
NORTH CAROLINA TEAM SESCO 2225 Freedom Drive Charlotte, NC 28208 704/372-4832 or 800/438-0353	
OHIO MAZZELLA LIFTING TECHNOLOGIES 21000 Aerospace Parkway Cleveland, OH 44142 440/239-5700 or 800/362-4601 Fax 440/239-5707	
PENNSYLVANIA AMICK ASSOCIATES, INC. 11 Sycamore Street Carnegie, PA 15106-0529 412/429-1212 or 800/445-9456 Fax 412/429-0191	
RAM MOTORS & CONTROLS, INC. 5460-B Pottsville Pike Leesport, PA 19533 610/916-8000 or 877/916-8018 Fax 610/916-7957	
TEXAS ABEL EQUIPMENT CO., INC. 3710 Cavalier Drive Garland, TX 75042 972/272-7706 Fax 972/272-6955	

SAFETY PRECAUTIONS

Each XL Air Hoist is built in accordance with the specifications contained herein and at the time of manufacture complied with our interpretation of applicable sections of the *American Society of Mechanical Engineers Performance Standard for Air Chain Hoist HST-5M, "Overhead Hoists B30.16," and the Occupational Safety and Health Act. Check each installation for compliance with the application, operation and maintenance sections of these articles.

The safety laws for elevators, lifting of people and for dumbwaiters specify construction details that are not incorporated in XL hoists. For such applications, refer to the requirements of applicable state and local codes, and the American National Safety Code for elevators, dumbwaiters, escalators and moving walks (ASME A17.1). Columbus McKinnon Corporation cannot be responsible for applications other than those for which CM equipment is intended.

* Copies of this Standard can be obtained from ASME Order Department, 22 Law Drive, Box 2300, Fairfield, NJ 07007-2300, U.S.A.



THIS SYMBOL POINTS OUT IMPORTANT SAFETY INSTRUCTIONS WHICH IF NOT FOLLOWED COULD ENDANGER THE PERSONAL SAFETY AND/OR PROPERTY OF YOURSELF AND OTHERS. READ AND FOLLOW ALL INSTRUCTIONS IN THIS MANUAL AND ANY PROVIDED WITH THE EQUIPMENT BEFORE ATTEMPTING TO OPERATE YOUR XL HOIST.



 **WARNING**

Usage of hoists that do not involve lifting of the load on the lower hook or using hoists in the inverted position without special precaution may cause an accident resulting in injury and/or property damage.

TO AVOID INJURY:

Consult Factory for information concerning using hoists in these applications.

 **WARNING**

Improper operation of a hoist can create a potentially hazardous situation which, if not avoided, could result in death or serious injury. To avoid such a potentially hazardous situation, the operator shall:

1. **Not** operate a damaged, malfunctioning or unusually performing hoist.
2. **Not** operate the hoist until you have thoroughly read and understood this Operating, Maintenance and Parts Manual.
3. **Not** operate a hoist which has been modified.
4. **Not** lift more than the rated load for the hoist.
5. **Not** use hoist with twisted, kinked, damaged or worn load chain.
6. **Not** use the hoist to lift, support, or transport people.
7. **Not** lift loads over people.
8. **Not** operate a hoist unless all persons are and remain clear of the supported load.
9. **Not** operate unless load is centered under hoist.
10. **Not** attempt to lengthen the load chain or repair damaged load chain.
11. Protect the hoist's load chain from weld splatter or other damaging contaminants.
12. **Not** operate hoist when it is restricted from forming a straight line from hook to hook in the direction of loading.
13. **Not** use load chain as a sling, or wrap load or chain around load.
14. **Not** apply the load to the tip of the hook or to the hook latch.
15. **Not** apply load unless load chain is properly seated in the chain wheel(s) or sprocket(s).
16. **Not** apply load if bearing prevents equal loading on all load chains.
17. **Not** operate beyond the limits of the load chain travel.
18. **Not** leave load supported by the hoist unattended unless specific precautions have been taken.

19. **Not** allow the load chain or hook to be used as an electrical or welding ground.
20. **Not** allow the load chain or hook to be touched by a live welding electrode.
21. **Not** remove or obscure the warnings on the hoist.
22. **Not** operate a hoist on which the safety placards or decals are missing or illegible.
23. **Not** operate a hoist unless it has been securely attached to a suitable support.
24. **Not** operate a hoist unless load slings or other approved single attachments are properly sized and seated in the hook saddle.
25. Take up slack carefully - make sure load is balanced and load holding action is secure before continuing.
26. Shut down a hoist that malfunctions or performs unusually and report such malfunction.
27. Warn personnel of an approaching load.

 **CAUTION**

Improper operation of a hoist can create a potentially hazardous situation which, if not avoided, could result in minor or moderate injury. To avoid such a potentially hazardous situation, the operator shall:

1. Maintain a firm footing or be otherwise secured when operating the hoist.
2. Check brake function by tensioning the hoist prior to each lift operation.
3. Use hook latches. Latches are to retain slings, chains, etc. under slack conditions only.
4. Make sure the hook latches are closed and not supporting any parts of the load.
5. Make sure the load is free to move and will clear all obstructions.
6. Avoid swinging the load or hook.
7. Make sure hook travel is in the same direction as shown on the controls.
8. Inspect the hoist regularly, replace damaged or worn parts, and keep appropriate records of maintenance.
9. Use the hoist manufacturer's recommended parts when repairing the unit.
10. Lubricate load chain per instructions in this manual.
11. **Not** use the hoist load limiting or warning device to measure load.
12. **Not** use limit stops as routine operating stops unless allowed by manufacturer. They are emergency devices only.
13. **Not** allow your attention to be diverted when operating hoist.
14. **Not** allow the hoist to be subjected to sharp contact with other hoists, structures, or objects through misuse.
15. **Not** adjust or repair the hoist unless qualified to perform such adjustments or repairs.

Hoist safety is up to you...

WARNING — DO NOT LIFT MORE THAN RATED LOAD.

1 CHOOSE THE RIGHT HOIST FOR THE JOB ...

Choose a hoist with the capacity for the job. Know the capacities of your hoists and the weight of your loads. Then match them.

The application, the size and type of load, the attachments to be used and the period of use must also be taken into consideration in selecting the right hoist for the job.



Remember the hoist was designed to ease our burden and carelessness not only endangers the operator, but in many cases, a valuable load.

WARNING — DO NOT OPERATE DAMAGED OR MALFUNCTIONING HOIST
— DO NOT OPERATE WITH TWISTED, KINKED OR DAMAGED CHAIN.

2 INSPECT

All hoists should be visually inspected before use, in addition to regular, periodic maintenance inspections.

Inspect hoists for operations warning notices and legibility.

Deficiencies should be noted and brought to the attention of supervisors. Be sure defective hoists are tagged and taken out of service until repairs are made.



Under no circumstances should you operate a malfunctioning hoist.

Check chain for gouged, twisted, distorted links and foreign material. Do not operate hoists with twisted, kinked or damaged links.

Load chain should be properly lubricated.

Hooks that are bent, worn or whose openings are enlarged beyond normal throat opening should not be used. If latch does not engage throat opening of hook, hoist should be taken out of service.

Check for misphasing—hook travel should correspond to control direction.

Carefully check limit switches without a load. Care should be taken not to damage the hoist.



WARNING — DO NOT PULL AT AN ANGLE. BE SURE HOIST AND LOAD ARE IN A STRAIGHT LINE.
— DO NOT USE LOAD CHAIN AS A SLING.

3 USE HOIST PROPERLY



Be sure hoist is solidly held in the uppermost part of the support hook arc.



Be sure hoist and load are in a straight line. Do not pull at an angle.



Be sure load is hooked securely. Do not tip load the hook. Do not load hook latch. Hook latch is to prevent detachment of load under slack chain conditions only.



Do not use load chain as a sling. Such usage damages the chain and makes the limit switch setting ineffective.



Do not operate with hoist head resting against any object. Lift the load gently. Do not jerk it.

WARNING — DO NOT LIFT PEOPLE OR LOADS OVER PEOPLE.

4

Do not lift co-workers with a hoist.

Make sure everyone is clear of the load when you lift.

Do not remove or obscure operational warning notices.



5

CLEANING

Hoists should be kept clean and free of dust, dirt, moisture, etc., which will in any way affect the operation or safety of the equipment.

LUBRICATION

Chain should be properly lubricated.

AFTER REPAIRS

Carefully operate the hoist before returning it to full service.



VIOLATION OF ANY OF THE WARNINGS LISTED MAY RESULT IN SERIOUS PERSONAL INJURY TO THE OPERATOR OR NEARBY PERSONNEL BY RELEASED LOAD OR BROKEN HOIST COMPONENTS.

FOREWORD

This manual contains important information to help you properly install, operate and maintain your hoist for maximum performance, economy and safety.

Please study its contents thoroughly before putting your hoist into operation. By practicing correct operating procedures and by carrying out the recommended preventative maintenance suggestions, you will experience long, dependable and safe service. After you have completely familiarized yourself with the contents of this manual, we recommend that you carefully file it for future reference.

The information herein is directed to the proper use, care and maintenance of the hoist and does not comprise a handbook on the broad subject of rigging. Rigging can be defined as the process of lifting or moving heavy loads using hoist and other mechanical equipment. Skill acquired through specialized experience and study is essential to safe rigging operations. For rigging information, we recommend consulting a standard textbook on the subject.

TABLE OF CONTENTS

ITEM	PAGE NO.	ITEM	PAGE NO.
MASTER PARTS DEPOTS AND SERVICE CENTERS	i	MAINTENANCE	
SAFETY PRECAUTIONS	ii	INSPECTIONS	10
HOIST SAFETY IS UP TO YOU	iii	FREQUENT INSPECTIONS	10,11
GENERAL INFORMATION		PERIODIC INSPECTIONS	11,12
SPECIFICATIONS	2	HOOK INSPECTION	11
REPAIR/REPLACEMENT POLICY	3	LOAD CHAIN	11
ACCESSORIES	3	PROTECTOR	11
INSTALLATION		LUBRICATION	
UNPACKING	4	HOIST	14
INSTALLING THE SUSPENSION		LOAD CHAIN	14
HOOK SUSPENSIONS	4	AIR LUBRICATOR	14
LUG SUSPENSIONS	6	TROLLEY	14
MOUNTING TROLLEY ON HOIST	6	ADJUSTMENTS	
INSTALLING TROLLEY SUSPENDED		HOIST BRAKE	14
HOIST ON BEAM	7	TROLLEY BRAKE	15
INSTALLING BREATHER	8	RECOMMENDED SPARE PARTS	15
INSTALLING MUFFLER	8	PREVENTIVE MAINTENANCE	15
AIR SUPPLY SYSTEM	8	TROUBLE SHOOTING	
CHECKING FOR TWIST IN LOAD CHAIN	9	HOISTS	16
CHAIN CONTAINER	9	MOTOR DRIVEN TROLLEY	16
CONTROL CORD	9	AIR DATA	17
OPERATING INSTRUCTIONS		HOIST DISASSEMBLY/REASSEMBLY	17
GENERAL	9	VALVE DISASSEMBLY/REASSEMBLY	18
ALL HOISTS	9	AIR MOTOR DISASSEMBLY/REASSEMBLY	19,20
HOIST WITH PLAIN TROLLEY	10	REMOVAL AND REPLACEMENT OF LOAD CHAIN	20
HOIST WITH GEARED TROLLEY	10	REEVING LOAD CHAIN	
HOIST WITH MOTOR DRIVEN TROLLEY	10	3 AND 5 TON DOUBLE REEVED UNITS	21
SAFETY PROCEDURES	10	6 AND 7 1/2 TON TRIPLE REEVED UNITS	21
		CUTTING CHAINS	22
		TESTING	22
		REPAIR PARTS	
		ORDERING INSTRUCTIONS	22
		EXPLODED VIEWS AND PARTS LISTS	24-39

GENERAL INFORMATION

SPECIFICATIONS

The XL Air Chain Hoist is a highly versatile material handling device that can be used to lift loads that are within its rated load capacity. Variable speed units with rated loads up to 7½ tons (7500 kg.) are available. The hoist can be supplied with a single hook suspension up to 6 ton (6000 kg.) capacity or suspended from a plain, geared or motor driven trolley. The standard lift is 10 feet and longer lifts can be provided on a per order basis.

This hoist's variable speed is obtained by varying the pressure of the pilot control lines through the pendant. This variable pilot pressure is used to modulate the main control valve for both direction and speed.

The standard features of the XL Air Chain Hoist include:

- Hardened, alloy steel, oblique lay liftwheel provides constant chain speed and reduces chain wear.
- Hoistaloy® load chain for long and dependable service.
- Lightweight cast aluminum frame and covers.
- Surface hardened, alloy steel, helical gears running in an oil bath provide smooth and quiet operation.
- Protector that prevents lifting an excessive overload.
- Variable speed hoist motor.
- Hardened, forged steel hooks equipped with latch.
- Double disc spring return brake.

- Shielded, lifetime lubricated ball bearings at all rotating points. Open bearings are used in gear case.
- Three stage gear reduction.



XL Hoist with Motor Driven Trolley

**TABLE 1-SPECIFICATIONS
XL AIR CHAIN HOISTS**

RATED LOAD	TONS kg.	2		3	5	6	7 1/2
		2000 Plain and Geared Trolley	2000 Motor Driven Trolley	3000	5000	6000	7500
*VARIABLE SPEEDS UP TO:	FPM	31		21	13	10	8.5
	MPM	9.4		6.4	3.9	3.0	2.6
MAXIMUM LIFT	FEET	100		100	100	100	100
	METERS	30.5		30.5	30.5	30.5	30.5
REEVING OF LOAD CHAIN		SINGLE		DOUBLE		TRIPLE	
MINIMUM HEADROOM	HOOK SUSPENDED - IN. (mm)	25 (635)		35.31 (897)		36.18 (919)	N/A
	TROLLEY SUSPENDED - IN (mm)	28.69 (729)		33 (838)	34.25 (870)	34.25 (870)	
RANGE OF TROLLEY ADJUSTABILITY "S" BEAMS		6X12.5' TO 15 X 42.9'		8 x 18.4 to 20 x 66.0'			
	IN.	3.33 TO 5.50		4.00 TO 6.250			
	FLANGE WIDTH mm	84.5 TO 139.7		101.6 TO 158.8			
VARIABLE MOTOR DRIVEN TROLLEY TRAVEL SPEED - FPM (MPM)		N/A		50 (15.2)			
APPROX. NET WEIGHT -LBS. (Kg.)							
HOOK SUSPENDED		347 (157)	----	421 (191)	421 (191)	453 (205)	N/A
WITH PLAIN TROLLEY		407 (184)	----	476 (216)	576 (261)	608 (275)	
WITH GEARED TROLLEY		452 (205)	----	491 (222)	586 (266)	618 (280)	
WITH MOTOR DRIVEN TROLLEY		----	505 (229)	569 (258)	611 (277)	643 (291)	

*Lifting speeds are based on 90 PSI air supply.

REPAIR/REPLACEMENT POLICY

All XL Air Chain Hoists are thoroughly inspected and performance tested prior to shipment. If any properly maintained hoist develops a performance problem due to a material or workmanship defect, as verified by factory, repair or replacement of the unit will be made to the original purchaser without charge. This repair/replacement policy applies only to XL Hoists installed, maintained and operated as outlined in this manual, and specifically excludes parts subject to normal wear, abuse, improper installation, improper or inadequate maintenance, hostile environmental effects and unauthorized repairs/modifications.

We reserve the right to change materials or design if, in our opinion, such changes will improve our product. Abuse, repair by an unauthorized person, or use of non-factory replacement parts voids the guarantee and could lead to dangerous operation. For full Terms of Sale, see Sales Order Acknowledgement. Also, refer to the back cover for Limitations of Warranties, Remedies and Damages, and Indemnification and Safe Operation.

ACCESSORIES

HOOK SUSPENSIONS

Hook suspensions are available for suspending 2 through 6 ton hoist from a trolley with a single load bar or for suspending the hoist from a fixed structure.

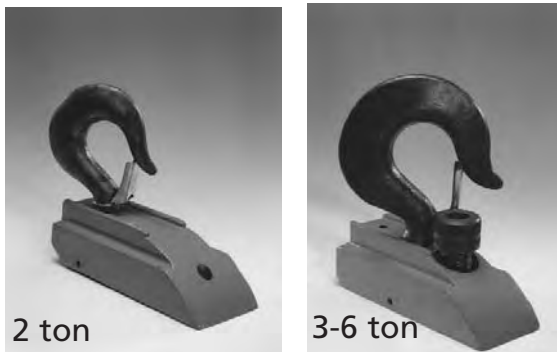

HOOK SUSPENSION

LUG SUSPENSIONS

Lug suspensions are required to suspend the XL Air Hoist from plain, geared or motor driven trolleys described below. When the hoist is to be suspended from a plain, geared or motor driven trolley, the lug suspension is attached to the hoist prior to shipment.

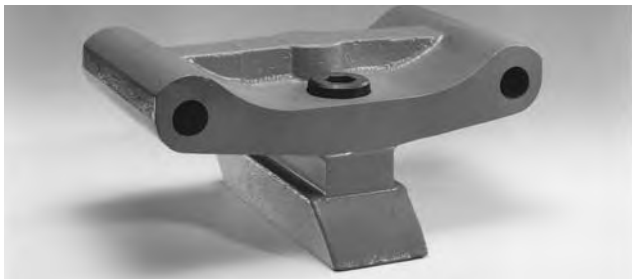

LUG SUSPENSION

PLAIN TROLLEYS

These are manual push type trolleys designed for use with the XL Air Hoist. The trolley is adjustable to operate on a range of American Standard 'S' beams and flat flanged beams. The plain trolley is mounted on the hoist prior to shipment.



PLAIN TROLLEY

GEARED TROLLEYS

The geared trolley is similar to the plain trolley except it is moved by the means of a hand chain. The hand chain rotates a pinion that drives gears attached to trolley wheels and moves trolley along the beam. The geared trolley is mounted on the hoist prior to shipment.



GEARED TROLLEY

MOTOR DRIVEN TROLLEYS

The motor driven trolley is similar to the geared trolley except the hand chain wheel is replaced with a gear reducer and an air motor. The motor is controlled by a bidirectional valve mounted to the motor and it is controlled by levers located on the pendant control station. A variable speed motor driven trolley is mounted on the hoist prior to shipment.



MOTOR DRIVEN TROLLEY

CHAIN CONTAINER

This accessory is used to hold the slack chain and is supplied complete with mounting hardware and instructions. The chain container is recommended for those applications where the slack chain will interfere with the load or drag on the floor as may be the case with double and triple reeved units. Chain containers are shipped separately and can be furnished for units already in use.



LATCHLOK® HOOKS

Latchlok hooks are available to replace the standard upper or lower latch type hooks (2-6 ton only). The unique design of the Latchlok hook assures that it will stay locked until the operator releases it by depressing the release button. It will not open accidentally—even if the load chain goes slack. Once opened, it can be shut with one hand or the weight of the load when it is lifted. Latchlok hooks can be supplied with the hoist or can be provided in kit form for hoists already in service.



LATCHLOK® HOOK

INSTALLATION

UNPACKING

After opening the carton, carefully inspect the hoist, control line, pendant, suspension, trolley and chain container for damage that may have occurred during shipment. If there is damage, refer to instructions on the packing slip envelope.

INSPECT FOR SHIPPING DAMAGE

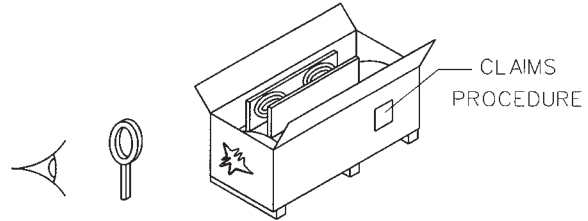

⚠ WARNING
Operating a unit with obvious external damage may cause load to drop and may result in personal injury and/or property damage.
TO AVOID INJURY: Carefully check unit for external damage prior to installation.

INSTALLING SUSPENSION

A. HOOK SUSPENSIONS

For hook suspended 2 through 6 ton units, the suspension is shipped separately and must be attached to the hoist as follows:

1. **2 Ton Single Reeved Units.** As shipped from the factory, the hook is rigid with the plane of the hook parallel to the long axis of the hoist. The hook can be changed to swivel type or the plane of the hook can be changed to perpendicular to the long axis of the hoist as follows:
 - a. If a swivel type hook is required, use a 1/4 inch (6.4 mm) drift, and working through the hole in the side of the suspension adapter, drive the hook nut pin into the nut so that it is flush with the side of the nut. Discard the loose pin packed with the suspension.

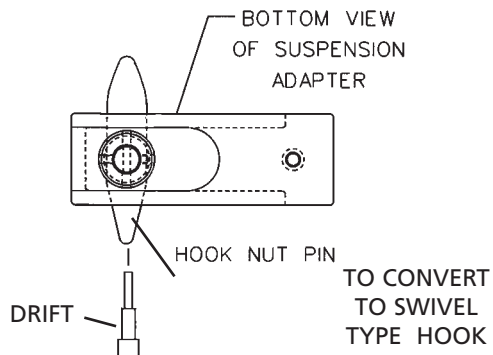

- b. If it is necessary to position the hook so that the plane of the hook is perpendicular to the long axis of hoist, first convert to a swivel type hook as described above. Rotate the hook 90 degrees and slide the loose pin (packed with the suspension) through the hole in the side of the suspension adapter and engage the hole in the hook nut.

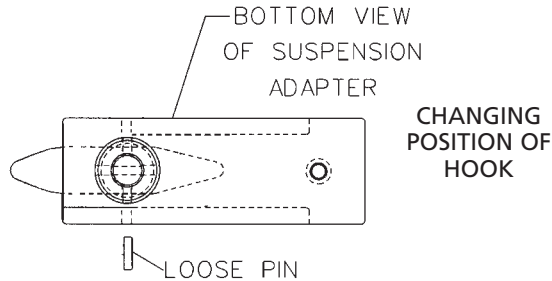

- c. After the hook is in the desired position, slide the suspension adapter into cavity on top of hoist and secure it using the suspension adapter screw from the kit. Tighten screw to a seating torque of 16 pound feet (22 NM).

NOTE: INSTALL BREATHER IN MAIN HOUSING AFTER

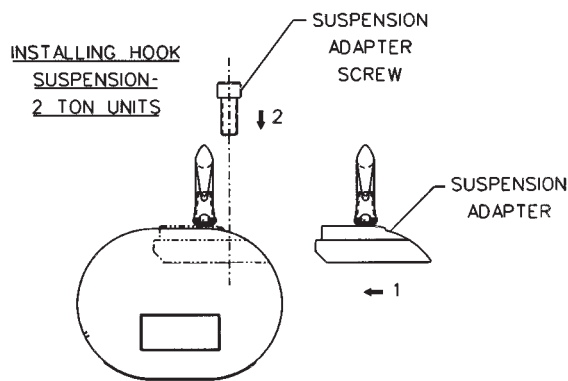

HOOK SUSPENSION IS ASSEMBLED TO HOIST. SEE PAGE 8.

2. **3 and 5 Ton Double Reeved and 6 Ton Triple Reeved Units.** As shipped from the factory, the hook is rigid with the plane of the hook parallel to long axis of hoist. The hook can be changed to swivel type or the plane of the hook can be changed to perpendicular to the long axis of the hoist as follows:

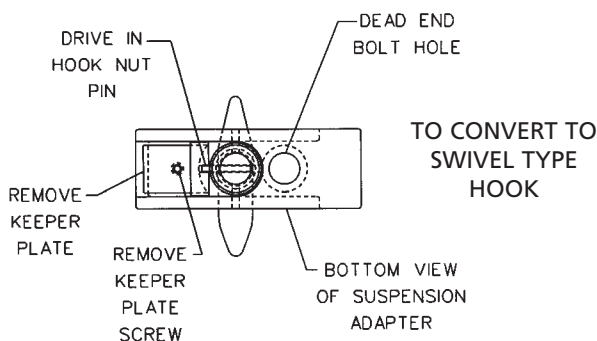

- a. If a swivel type hook is required, remove and discard the keeper plate screw and keeper plate. Then using a hammer, drive the hook nut pin into nut so that the end of the pin is flush with side of the nut.
- b. If it is necessary to position the hook so that the plane of the hook is perpendicular to the long axis of the hoist, first convert to a swivel type hook as described above but do not discard the keeper plate and screw. Turn hook 90 degrees and insert the loose pin (packed with the suspension) into a hole in the hook nut. Loosely reassemble keeper plate to the suspension adapter so that the hook is free to swivel approximately 45 degrees in either direction. The hook will be made rigid after suspension is attached to the hoist.

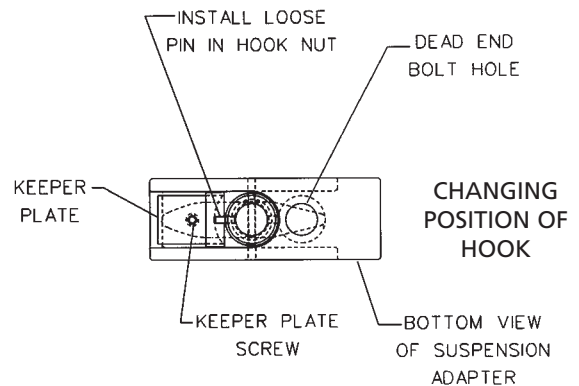

- c. Slide the suspension adapter into the cavity on top of hoist. Install the dead end bolt and thread it by hand to engage the dead end block (3 and 5 ton double reeved units) or idler sheave hanger (6 ton units). Then tighten the dead end bolt to a seating torque of 120 pound feet (160NM).

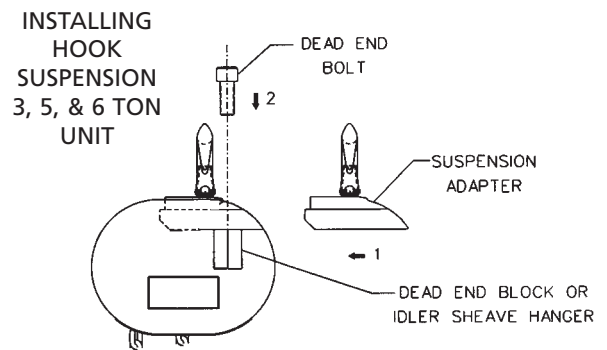

If the hook is to be perpendicular to long axis of hoist per step b above, rotate the hook to that position and firmly tighten the keeper plate screw while making sure the loose pin engages the slot in keeper plate.

NOTE: INSTALL BREATHER IN MAIN HOUSING AFTER HOOK SUSPENSION IS ASSEMBLED TO HOIST. SEE PAGE 8.

B. LUG SUSPENSIONS

The following instructions are provided to cover installing the lug suspension after the hoist has been reassembled following inspection and/or repair. On hoists shipped from factory, the lug suspension is installed prior to mounting the trolley.

1. **2 Ton Single Reeved Units.** Slide the suspension adapter into the cavity on top of hoist and secure it using the suspension adapter screw. Tighten the screw to a seating torque of 16 pound feet (22 NM).

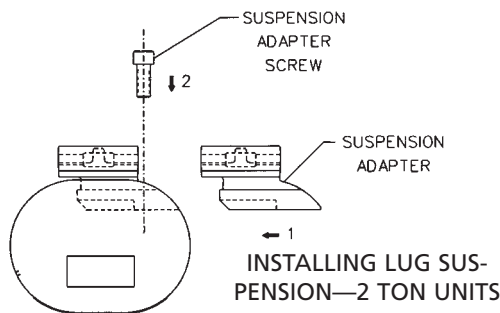

2. **3 And 5 Ton Double Reeved And 6 And 7 1/2 Ton Triple Reeved Units.** Slide the suspension adapter into cavity on top of hoist. Install the dead end bolt and thread it by hand to engage the dead end block (3 and 5 ton double reeved units) or idler sheave hanger (6 and 7 1/2 ton triple reeved units). Then tighten the dead end bolt to a seating torque of 120 pound feet (160 NM).

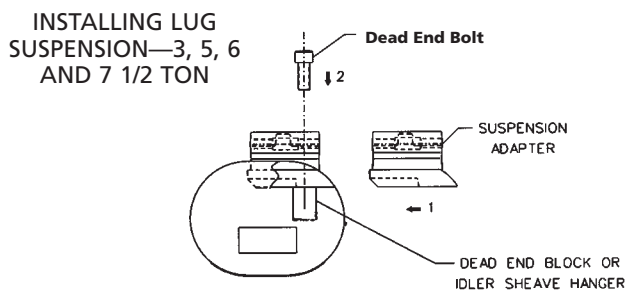

MOUNTING TROLLEY ON HOIST

The following instructions are provided to cover mounting plain, geared and motor driven trolleys after the hoist has been reassembled following inspection and/or repair. On units shipped from factory, these trolleys are mounted on the hoists.

1. Measure the actual width of the beam flange on which the trolley is to operate. To determine proper trolley side frame spacing to assure that adequate wheel clearance is provided, the distance between the beam flange and the inside face of the trackwheel flange (approximately 1/8 to 3/16 inch on straight runway beams, 3/16 to 1/4 inch on curved beams for 2 ton units. See Figure 2 -page 7 and 1/4 inch for straight runway beams, 3/8 inch on curved beams for 3 thru 7 1/2 ton units. See Figure 1 - page 7).
2. Use Table 2 (page 7) to determine proper spacing for 2 ton plain and geared units. On 2 ton motor driven trolleys and, 3 thru 7 1/2 ton capacity units, proper spacing is obtained by varying the number of spacer washers (furnished with trolley) that are installed on the suspension pins.

MOUNTING TROLLEY ON HOIST

HANDWHEEL OR TROLLEY MOTOR GEARED OR MOTOR DRIVEN TROLLEY ONLY

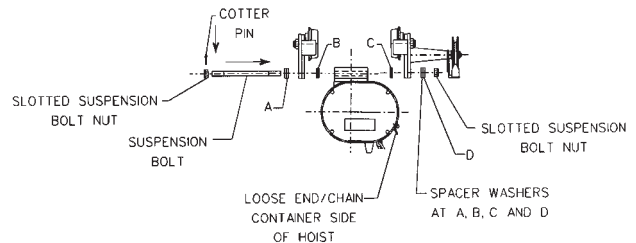

3. For 2 ton units, assemble a slotted nut to one end of each suspension bolt and secure it using a cotter pin. Spread legs of cotter pin to keep it in place. Using Table 2 (page 7) as a reference for washer spacing, assemble side frames and bolts and washers together as shown below. Do not install remaining cotter pins at this time. These are to be installed after the trolley is mounted on the beam.

For 3 thru 7 1/2 ton units, temporarily assemble trolley to hoist using 3 or 4 washers at each end of suspension pins, between side plates and suspension lug. Tighten pin nuts for accurate check of spacing. Measure the distance between the inside faces of the trackwheel flanges and compare to the dimension required. Remove trolley side plates and add or remove an equal number of inside spacer washers as required to obtain proper distance between wheels. When spacing is correct, install all remaining spacer washers on the outside ends of each suspension pin and secure the pins with lockwashers and hex nut (See Note Below). The nuts should not be completely tightened until after hoist and trolley are mounted onto beam.

NOTE: It is very important that all spacer washers that come with the trolley be used. Install remaining spacer washers equally on out side ends of each suspension pin.

⚠ WARNING

Using other than factory supplied suspension adapter screw or dead end bolt to attach suspension adapter to hoist may cause the screw or bolt to break and allow the hoist and load to fall.

TO AVOID INJURY:

Use only the factory supplied suspension adapter screw or dead end bolt and tighten these to the seating torque specified above.

- On geared trolleys, make sure the handwheel is on side opposite the loose end/chain container side of the hoist. On motor driven trolleys make sure the motor is located on the loose end/chain container side of the hoist.

INSTALLING TROLLEY SUSPENDED HOIST ON BEAM

⚠ WARNING
Operating the trolley on a beam that has no rail stops may allow the trolley to fall off the end of the beam.
TO AVOID INJURY:
Install rail stops at each end of the beam on which the trolley is to operate.

Stops must be positioned to contact the trolley side frames and not exert impact force on the hoist.

Trolleys are mounted on the hoist prior to shipment and side frames are positioned for the nominal beam flange width specified on the order. However, due to variations in beam flange widths, actual beam flange width should be measured to determine the exact distribution of the spacer washers. See Mounting Trolley On Hoist Section.

⚠ WARNING
If washer spacing recommendations are not followed, trolley may fall from beam.
TO AVOID INJURY:
Measure the actual beam flange on which the trolley is to operate and use Table 2 to determine the arrangement of the spacer washers for that flange width.

NOTE: USE OF OTHER THAN SUPPLIED SPACER WASHERS MAY CAUSE IMPROPER TRACKWHEEL SPACING.

Before installing geared or motor driven trolleys (2 ton only) on the beam, lubricate the trackwheel gears and pinion with Texaco Novatex #2 or equivalent heavy cup grease.

On open end beams, remove rail stops, lift hoist/trolley into position and slide the hoist/trolley assembly onto beam flange. Reinstall the rail stops.

On closed end beams, loosen the suspension bolt nuts on one side of trolley and slide one side frame out far enough to clear the beam flange. Lift hoist/trolley assembly up so that trackwheels are riding on beam flange. Draw side frames together by tightening the suspension bolt nuts snugly.

Be sure to install cotter pins through slotted nuts and hole in suspension bolts and spread legs of cotter pins to secure on 2 ton plain and geared units. For 2 ton motor driven trolley and 3 thru 7 1/2 ton units, be sure lockwashers are positioned properly on the suspension pins and completely tightened.

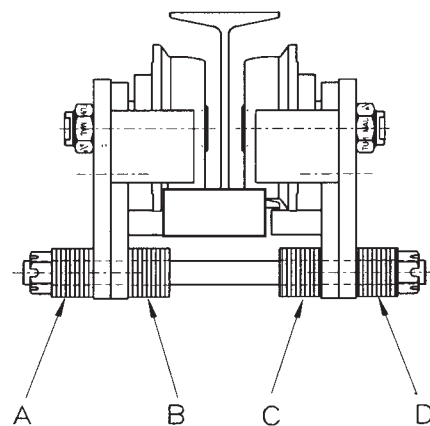
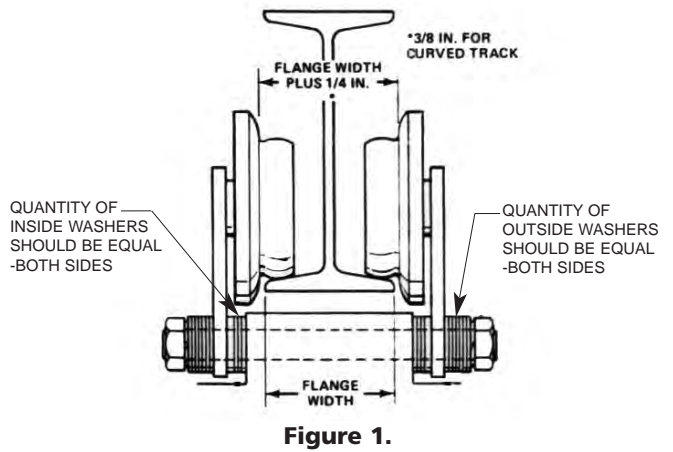

Figure 2.
Table 2. Trolley Spacer Washer Arrangement Plain and Geared

	FLANGE WIDTH IN.(mm)	2 Ton			
		No. of Washers			
		A	B	C	D
Standard Trolleys	3 3/8 (82.7)	13	0	0	13
	3 5/8 (92.0)	11	2	2	11
	3 7/8 (98.4)	10	3	4	9
	4 (101.6)	9	4	4	9
	4 1/8 (104.7)	8	5	5	8
	4 5/8 (117.4)	5	8	8	5
	5 (127.0)	3	10	10	3
	5 1/8 (130.1)	3	10	11	2
	5 1/4 (133.3)	2	11	12	1
5 1/2 (139.7)	0	13	13	0	
Special Trolleys	5 5/8 (142.9)	12	1	1	12
	6 (1252.4)	10	3	3	10
	6 1/4 (158.7)	9	4	5	8
	6 3/8 (161.9)	8	5	6	7
	7 (177.8)	4	9	9	4
	7 1/8 (181.0)	3	10	10	3
	7 1/4 (184.1)	3	10	11	2
	7 3/8 (187.3)	2	11	12	1
7 1/2 (190.5)	1	12	12	1	
7 5/8 (193.7)	0	13	13	0	
*Minimum Beam Radius ft. (M)		4'-0" (1.22)			

*Dimension applies to minimum S-beam and will vary with larger s-beams.

Units with anti-tipping rollers should be adjusted to provide 1/8" maximum gap between the bottom of the beam and the roller. Run the trolley the length of the beam to check for tight places. Readjust if needed.

On geared trolleys, the bottom of the hand chain loop is normally located two feet (0.6M) above the floor. If it is desired to change this, find the unwelded link and open it by spreading with a chisel or twist one end with a wrench while holding the other end in a vise or another wrench. Remove an even number of links (2,4,6, etc.) as necessary to shorten the chain or add an even number of links to lengthen the chain (when lengthening the chain, another open link will be required and this can be made from a welded link by cutting through weld with a hack-saw). Make certain that the chain is not twisted—then re-install and close open links.

NOTE: AFTER THE UNIT IS CONNECTED TO THE AIR SUPPLY SYSTEM (SEE BELOW), SUSPEND A CAPACITY LOAD FROM THE HOIST AND OPERATE THE TROLLEY OVER THE ENTIRE LENGTH OF THE RUNWAY OR MONO RAIL SYSTEM TO BE SURE THAT THE ADJUSTMENTS AND OPERATION IS SATISFACTORY. ON SYSTEMS WITH CURVES, THE EDGES OF THE RAIL AT THE CURVED SECTIONS SHOULD BE KEPT LIGHTLY LUBRICATED WITH GREASE.

⚠ WARNING

An excessively worn beam flange may fail and allow the trolley to fall from the beam.

TO AVOID INJURY:

Periodically inspect the beam flange for wear. Replace beam if flange is worn.

INSTALLING MUFFLER

Install the 3" long 1 1/4" NPT pipe nipple through the hole in the motor end cover and thread it into the valve exhaust port. Install the 1 1/4" NPT pipe elbow onto the end of the pipe nipple. Tighten the elbow until it faces downward. Install the muffler into the elbow and tighten.

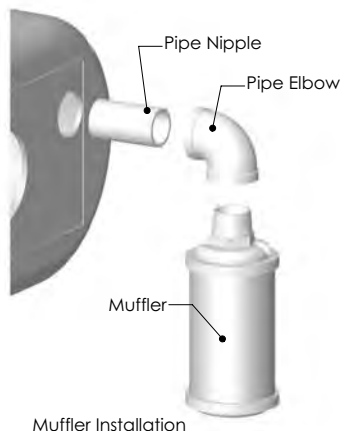

⚠ WARNING

Operating hoist without muffler can cause hearing loss.

TO AVOID INJURY:

To avoid injury, only operate hoist with muffler securely attached.

INSTALLING BREATHER

After the hook suspension is assembled to the hoist or after the hoist and trolley are mounted on the beam, remove the upper plug from the main housing (652-110) and install the breather (inside information envelope). Failure to install the breather could damage oil seals and thus cause oil leaks.

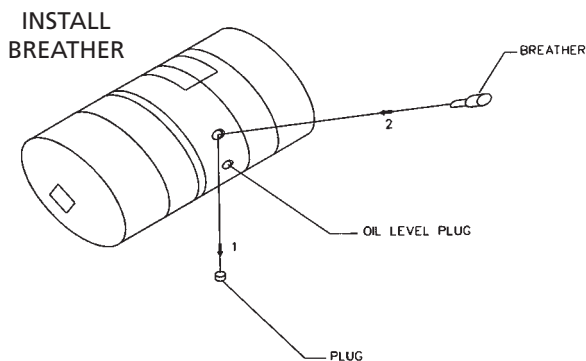

AIR SUPPLY SYSTEM

Connect the hoist to a filtered and lubricated air source using a 1" (25.4 mm.) I.D. hose (see Figure 3). Do not use smaller diameter hose, since it will restrict air flow and reduce hoist performance. If the hoist is suspended from a trolley, provide sufficient hose to reach from the source to the farthest point of trolley travel. Hose Trolleys are recommended to keep the hose up and out of the way.

A filter and lubricator (see Figure 3) **must** be installed between the air source and the air hose leading to the hoist. These keep the air flowing free from dirt and add lubricant to the air so internal parts of the motor are constantly lubricated. Use a good grade of air powered tool oil or SAE 10W machine oil. Such oil can be obtained from CM®, Coffing, or Budgit.



Figure 3. Filter and Lubricator Unit

The recommended operating air pressure for the hoist is 90 psig. When line pressure exceeds 100 psig (at the hoist when it is lifting rated load), it is recommended that a pressure regulator be provided in the air supply line to keep the pressure at 90 psig. Although there is a wide range of pressures within which the hoist will operate, motor efficiency decreases as the air pressure drops. Excessive moisture in the air line may cause rust or ice to form in the muffler when air expands as it passes through the motor. Install a moisture separator in the air line and an after cooler between compressor and air receiver to help prevent moisture problems.

WARNING

Allowing the hook block to run into the bottom of the hoist when raising a load or allowing the dead end stop to run into the frame when lowering a load may break the chain and allow the load to drop.

TO AVOID INJURY:

Do not allow the hook block or dead end stop to contact the bottom of the hoist.

CHECKING FOR TWIST IN LOAD CHAIN

3 And 5 Ton Double Reeved Units

The best way to check for this condition is to run the lower hook, without a load, to within 2 feet (0.6M) of the hoist. If the dead end of chain has been properly installed, a twist can occur only if the lower hook block has been capsized between the strands of chain. Reverse capsize to remove twist.

6 And 7 1/2 Ton Triple Reeved Units

On these models, the load chain is dead ended on top of the lower hook block. If chain has been properly installed, the only way a twist can occur is if the lower hook block has been capsized between the strands of chain. If this has occurred, two strands of chain will be wrapped around each other and to remove twist, reverse the capsize.

CHAIN CONTAINER

If a chain container is to be used, attach it to the hoist frame and place chain in container per instructions provided with the chain container kit.

UNDER NO CIRCUMSTANCES SHOULD THE HOOK BLOCK OR LOAD BE PERMITTED TO COME IN CONTACT WITH THE CHAIN CONTAINER. IF CONTACT IS MADE, THE FUNCTION OF THE CHAIN CONTAINER CAN BE INTERFERED WITH, THE CONTAINER MAY BE DAMAGED AND IT COULD FALL OFF OF THE HOIST.

PENDANT HOSE

Unless ordered on a special basis, the hoist is supplied with a pendant hose that will position the pendant approximately 4 feet (1.2M) above the lower hook when it is at the lower limit of lift. If this places the pendant too close to the floor, the pilot hoses and strain cable can be shortened with diagonal cutters.

WARNING

Tying knots or loops to shorten the drop of the pendant will make the strain relief ineffective and the pilot hoses may break or collapse restricting air flow.

OPERATING INSTRUCTIONS

GENERAL



1. The Protector is designed to allow the first reduction gear to slip on an excessive overload. An overload is indicated when the hoist will not raise the load. Also, some clutching noise may be heard if the hoist is loaded beyond rated capacity. Should this occur, immediately release the  (Up) control to stop operation of the hoist. At this point, the load should be reduced to the rated hoist capacity or the hoist should be replaced with one of the proper capacity. When the excessive load is removed, normal hoist operation is automatically restored.

CAUTION: THE PROTECTOR IS SUSCEPTIBLE TO OVER HEATING AND WEAR WHEN SLIPPED FOR EXTENDED PERIODS. UNDER NO CIRCUMSTANCE SHOULD THE PROTECTOR BE ALLOWED TO SLIP FOR MORE THAN A FEW SECONDS.

Due to the above, a hoist equipped with a Protector is not recommended for use in any application where there is a possibility of adding to an already suspended load to the point of overload. This includes *dumbwaiter installations, containers that are loaded in mid-air, etc.

*Refer to limitations on Page ii concerning dumbwaiter applications.

Also, if a XL Hoist with a Protector is used at unusual extremes of ambient temperatures, above 150°F (65°C) or below 15° F (-9°C) changes in lubricant properties may permit the hoist to raise larger loads than under normal operating conditions and presents possibility of damage or injury.

2. Hoist operation is controlled by depressing the pendant throttle control levers. Depressing the UP () lever will move the lower hook towards the hoist and depressing the DOWN () lever will move the lower hook away from the hoist. The speed of lifting and lowering can be varied by the distance the lever is depressed. To stop lifting and lowering, release the lever. The up and down levers are momentary type and the hoist will operate in the selected direction as long as the lever is held in the depressed direction. Release the lever and the hoist will stop.
3. If material being handled must be immersed in water, pickling baths, any liquid, dusty or loose solids, use a sling chain of ample length so that the hook is always above the surface. Bearings in the hook block are shielded only against ordinary atmospheric conditions.
4. Read the operation section of American National Standard ASME B30.16.

ALL HOISTS

1. Before picking up a load, check to see that the hoist is directly overhead.
2. When applying a load, it should be directly under the hoist or trolley. Avoid off-center loading of any kind.

3. Take up a slack load chain carefully and start the load easily to avoid shock and jerking of the hoist load chain. If there is any evidence of overloading, immediately lower the load and remove the excess load.
4. Do not allow the load to swing or twist while hoisting.
5. Do not allow the load to bear against the hook latch.

HOIST WITH PLAIN TROLLEY

This unit should be moved by pushing on the suspended load or by pulling the empty hook.

HOIST WITH GEARED TROLLEY

This unit should be moved by means of the trolley hand chain. Pull on the chain farthest from end toward which the unit is to travel.

HOIST WITH MOTOR DRIVEN TROLLEY

This unit should be moved by operating the controls located on the upper block of the pendant. Anticipate the stopping point and allow trolley to coast to a smooth stop. Reversing or "plugging" to stop the trolley causes sway- ing of load.

SAFETY PROCEDURES

For safety precautions and a list of Do's and Do Not's for safe operation of hoists, refer to page ii.

1. When preparing to lift a load, be sure that attachments to the hook are firmly seated in the hook saddle. Avoid off center loading of any kind, especially loading on the tip of the hook.
2. When lifting, raise load only enough to clear the floor or support and check to be sure that the attachments to the hook and load are firmly seated. Continue lift only after you are assured the load is free of all obstructions.
3. Do not load hoist beyond the rated load shown on hoist identification plate and capacity labels. Overload can cause immediate failure of some load-carrying part or create a defect causing subsequent failure at less than rated load. When in doubt, use the next larger capacity of XL Hoist.
4. Do not use this or any other overhead materials handling equipment for lifting persons.
5. Stand clear of all loads and avoid moving a load over the heads of other personnel. Warn personnel of your intention to move a load in their area.
6. Do not leave load suspended in air unattended.
7. Permit only qualified personnel to operate unit.
8. Do not wrap the load chain around the load and hook onto itself as a choker chain. Doing this will result in:
 - a. The loss of the swivel effect of the hook which could mean twisted chain and a jammed lift wheel.
 - b. The chain could be damaged at the hook.
9. On double and triple reeved hoists, check for twists in the load chain. A twist can occur if the lower

hook block has been capsized between the strands of chain. Reverse the capsize to remove the twist.

10. Do not allow the load to bear against the hook latch. The latch is to help maintain the hook in position while the chain is slack before taking up slack chain.

⚠ WARNING

Allowing the load to bear against the hook latch and/or hook tip can result in loss of load.

TO AVOID INJURY:

Do not allow the load to bear against the hook latch and/or hook tip. Apply load to hook bowl or saddle only.

11. Take up a slack load chain carefully and start load easily to avoid shock and jerking of hoist load chain. If there is any evidence of overloading, immediately lower the load and remove the excess load.
12. Do not allow the load to swing or twist while hoisting.
13. STAY ALERT! Watch what you are doing and use common sense. Do not use the hoist when you are tired, distracted or under the influence of drugs, alcohol or medication causing diminished control.

INSPECTION

MAINTENANCE

To maintain continuous and satisfactory operation, a regular inspection procedure must be initiated to replace worn or damaged parts before they become unsafe. Inspection intervals must be determined by the individual application and are based on the type of service to which the hoist will be subjected and degree of exposure to wear, deterioration or malfunction of the critical components.

The type of service to which the hoist is subjected can be classified as "Normal," "Heavy," or "Severe."

Normal Service: Involves operation with randomly distributed loads within rated load limit, or uniform loads less than 65 percent of rated load for not more than 25 percent of the time.

Heavy Service: Involves operating the hoist within rated load limit which exceeds normal service.

Severe Service: Normal or heavy service with abnormal operating conditions.

Two classes of inspection—**Frequent and Periodic**—must be performed.

FREQUENT INSPECTIONS: These inspections are visual examinations by the operator or other designated personnel. Records of such inspections are not required. The frequent inspections are to be performed monthly for normal service, weekly to monthly for heavy service, and daily to weekly for severe service, and they should include those items listed in Table 3.

PERIODIC INSPECTIONS: These inspections are visual inspections of external conditions by an appointed person.

Records of periodic inspections are to be kept for continuing evaluation of the condition of the hoist. Periodic inspections are to be performed yearly for normal service, semi-annually for heavy service and quarterly for severe service, and they are to include those items listed in Table 3.

CAUTION: ANY DEFICIENCIES ARE TO BE CORRECTED BEFORE THE HOIST IS RETURNED TO SERVICE. ALSO, THE EXTERNAL CONDITIONS MAY SHOW THE NEED FOR DISASSEMBLY TO PERMIT A MORE DETAILED INSPECTION, WHICH, IN TURN, MAY REQUIRE THE USE OF NONDESTRUCTIVE TYPE TESTING.

HOOK INSPECTION

Hooks damaged from chemicals, deformations or cracks, or that have more than a 10° twist from the hook's unbent plane, excessive opening or seat wear must be replaced. Also, hooks that are opened and allow the latch to not engage the tip must be replaced. Any hook that is twisted or has excessive throat opening indicates abuse or overloading of the unit. Inspect other load sustaining parts for damage.

On latch type hooks, check to make sure that the latch is not damaged or bent and that it operates properly with sufficient spring pressure to keep the latch tightly against the tip of the hook and allow latch to spring back to tip when released. If latch does not operate properly, it should be replaced. See below to determine when the hook must be replaced.

LATCH TYPE HOOK (Upper and Lower) TO MEASURE OPENING, DEPRESS LATCH AGAINST HOOK BODY AS SHOWN.

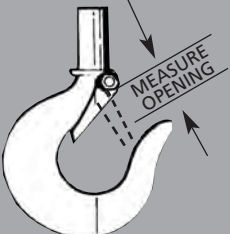

*UPPER HOOK NOT AVAILABLE FOR 7 1/2 TON

CAPACITY (TONS)	Replace Hook When Opening is Greater Than
2	1 1/2 IN. 38.1 mm
3, 5, 6 AND 7 1/2	2 3/8 IN. 60.3 mm

LATCHLOCK® TYPE HOOK (UPPER AND LOWER)

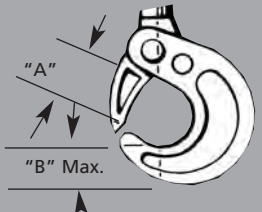

CAPACITY (TONS)	Replace Hook When Opening Or Seat are:	
	"A" Max.	"B" Mn.
2	2 1/2 IN. 63.5 mm	1 1/8 IN. 28.5mm
3, 5, and 6	2 15/16 IN. 74.6 mm	1 13/32 IN. 35.7mm

Hook Inspection

LOAD CHAIN

Cleaning and Inspection

First clean the load chain with a non-acid or non-caustic type solvent. Then slack the chain and make a link-by-link inspection for nicks, gouges, twisted links and excessive wear or stretching. Chain exhibiting wear should be checked throughout its entire length and replaced if worn beyond serviceable limits.

Checking For Load Chain Wear

Slack the portion of the chain that normally passes over the liftwheel. Examine the interlink area for the point of maximum wear (polishing). Measure and record the stock diameter at this point of the link. Then measure stock diameter in the same area on a link that does not pass over the liftwheel (use the link adjacent to the loose end link for this purpose). Compare these two measurements. If the stock diameter of the worn link is 0.010 inches (0.254mm), or greater, less than the stock diameter of the unworn link, the chain must be replaced.

Note that worn chain can be an indication of worn hoist components. For this reason, the hoist's chain guides, hook blocks and liftwheel should be examined for wear and replaced as necessary when replacing worn chain.

Also, these chains are specially heat treated and hardened and should never be repaired.

⚠ WARNING
Using other than factory supplied load chain may cause the chain to jam in the hoist and/or allow the chain to break and the load to drop.
TO AVOID INJURY:
Due to size requirements and physical properties, use only Hoistaloy® load chain in the XL Hoists.

IMPORTANT: DO NOT USE REPLACED CHAIN FOR OTHER PURPOSES SUCH AS LIFTING OR PULLING. LOAD CHAIN MAY BREAK SUDDENLY WITHOUT VISUAL DEFORMATION. FOR THIS REASON, CUT REPLACED CHAIN INTO SHORT LENGTHS TO PREVENT USE AFTER DISPOSAL.

PROTECTOR™

The Protector should operate for the normal life of hoist without service. The device has been calibrated at the factory for a specific capacity/gear ratio of the XL Air Hoist. It is not adjustable and it is not interchangeable with other capacities/gear ratios.

RATED LOAD TONS (Kg.)	*LIFT SPEED FPM (MPM)	COLOR CODE
2 (2000)	31 (14.0)	Blue
3 (3000)	21 (9.5)	Orange
5 (5000)	13 (5.9)	Green
6 (6000)	10(4.5)	Blue
7 1/2 (7500)	8.5 (3.8)	Green

Table 3. Minimum Frequent Inspections

TYPE OF SERVICE			ITEM
Normal	Heavy	Severe	
↑ Monthly ↓	↑ Weekly to Monthly ↓	↑ Daily to Weekly ↓	a) Brake for evidence of slippage. b) Control functions for proper operation. c) Hooks for damage, cracks, twists, excessive throat opening. latch engagement and latch operation—see page 13. d) Load chain for adequate lubrication, as well as for signs of wear, damaged links or foreign matter—see page 15. e) Load chain for proper reeving and twists.

Table 4. Minimum Periodic Inspections

TYPE OF SERVICE			ITEM
Normal	Heavy	Severe	
↑ Yearly ↓	↑ Every 6 Months ↓	↑ Every 3 Months ↓	a) All items listed in Table 3 for frequent inspections. b) External evidence of loose screws, bolts or nuts. c) External evidence of worn, corroded, cracked or distorted hook block, gears, bearings, dead end block, dead end pin, dead end bolt and suspension components. d) External evidence of damage to hook retaining nut and pin. Also check the upper suspension adapter making sure it is fully seated in the hoist frame and that suspension adapter screw or dead end bolt is tight. e) External evidence of damage or excessive wear of the liftwheel and hook block sheave chain pockets. Widening and deepening of the pockets may cause the chain to lift-up in the pocket and result in binding between liftwheel and chain guide or between the sheave and hook block. Also, check the chain guide for wear or burring where the chain enters the hoist. Severely worn or damaged parts should be replaced. f) External evidence of excessive wear of brake parts, and brake adjustment—see page 14. g) Check the operation of the control station making sure the paddles operate freely and do not stick in either position. h) Check air supply hose and control hose for kinks, cuts, leaks and damage i) Inspect trolley trackwheels for external wear on tread and flange and for wear on internal bearing surfaces as evidenced by a looseness on the stud. Suspension components for damage, cracks, wear and operation. Also check suspension adapter screw or dead end bolt for proper tightness—(see pages 4, 5, and 6). j) Inspect the loose end link, loose end screw, dead end block on double reeved units and dead end plate on triple reeved units. Replace worn or distorted parts. k) Inspect the hook for excess free play or rotation. Replace worn parts as evidenced by excess free play or rotation. l) Inspect for oil leaks at the gasket on either side of intermediate plate. Tighten the screws used to attach the main housing and brake housing to intermediate plate. If leak persists, disassemble hoist (see page 17) and replace gaskets. m) Inspect inside of motor and brake housings for presence of oil. Oil in motor housing may be excess chain lubricant or a leaking seal. Wipe out oil and monitor. If leak persists, replace seal (652-122 or 652-132). Oil in brake housing is due to leaking seal. Replace seal (652-122 or 652-134). n) Inspect all splines for signs of wear and deterioration. Replace splined parts if worn or damaged.

Notes

LUBRICATION

! WARNING

The lubricants used in and recommended for the XL Air Hoist may contain hazardous materials that mandate specific handling and disposal procedures.

TO AVOID CONTACT AND CONTAMINATION:

Handle and dispose of lubricants only as directed in applicable material safety data sheets and in accordance with applicable local, state and federal regulations.

NOTE: TO ASSURE LONG LIFE AND TOP PERFORMANCE, BE SURE TO LUBRICATE THE VARIOUS PARTS OF THE XL AIR HOIST USING THE LUBRICANTS SPECIFIED BELOW. IF DESIRED, THESE LUBRICANTS MAY BE PURCHASED FROM THE FACTORY.

HOIST LUBRICATION

Gears. Check the oil level in gear housing at least once a month, maintaining it at the bottom of oil level hole in the main housing (652-110).

Drain the housing every 2-3 years and refill with one gallon (3.86 liters) of gear oil Hulbest EP ISO VG 68 thru 460 (H-2 Classification).

CAUTION: THE PROTECTOR IS DESIGNED TO OPERATE IN THE ABOVE MENTIONED OIL. DO NOT USE ANY OTHER TYPE OF LUBRICANT OR THE PROTECTOR WILL NOT OPERATE PROPERLY AND PARTS COULD BE DAMAGED.

Chain Guides, Liftwheel & Sheave Wheels.

When the hoist is disassembled for inspection and/or repair, the chain guides, sheave wheels (on multi-reeved units) and liftwheel must be lubricated with Lubriplate Bar and Chain Oil 10-R (Fiske Bros. Refining Co.) prior to reassembly. Apply sufficient lubricant to obtain natural runoff and full coverage.

Load Chain. Keep chain lubricated with a small amount of lubricant. This will greatly increase the life of load chain. Do not allow the chain to run dry.

Keep it clean and lubricate at regular intervals with Lubriplate Bar and Chain Oil 10-R (Fiske Bros. Refining Co.) or equal lubricant. Normally, weekly lubrication and cleaning is satisfactory, but under hot and dirty conditions, it may be necessary to clean the chain at least once a day and lubricate it several times between cleanings. When lubricating the chain, apply sufficient lubricant to obtain natural runoff and full coverage.

! WARNING

Used motor oils contain known carcinogenic materials.

TO AVOID HEALTH PROBLEMS:

Never use used motor oils as a chain lubricant. Only use Lubriplate Bar and Chain Oil 10-R or equal as a lubricant for the load chain.

Bearings. All bearings except the lower hook thrust bearings are pre-lubricated or are in an oil bath and need no lubrication. The lower hook thrust bearing should be lubricated at least once a month with heavy duty machine oil.

Service Air Line Lubricator. The air line filter and lubricator is the only source of lubrication for control valves and air motor. Fill lubricator with a good grade air tool oil or 10W machine oil. Feed one drop of oil for every 50 to 75 cubic feet of air going through the air motor.

Miscellaneous. If the unit is disassembled, splines inside the coupling (652-103) should be coated with an EP type grease (such as Evans Products Co. Anti-Scoring Extreme Pressure Lub. No. 3) before reassembly.

TROLLEY LUBRICATION

Trackwheel bearings are pre-lubricated and require no lubrication.

Geared Trolley. Once a month lubricate trackwheel gears with Texaco Novatex No. 2 or an equivalent heavy cup grease or graphite grease.

Every six months lubricate handwheel shaft bearings in 3-in-1 machine oil.

Motor Driven Trolley. Once a month lubricate trackwheel gears with Texaco Novatex No. 2 or an equivalent heavy cup grease or graphite grease.

For 2-7 1/2 ton trolleys, the right angle worm gear reducer oil should be changed after the first 100 hours of operation, then after every 2500 hours of normal service. When replacing oil due to repairs or service, use Mobil SHC-626 or equal, for each oil change.

ADJUSTMENTS HOIST BRAKE

The correct air gap between spacer tube and field plate when brake is not activated, is 0.025 inch (.63 mm) and need not be adjusted until the gap reaches 0.045 inch (1.14 mm).

To adjust the brake, proceed as follows:

1. Turn off air supply and bleed stored air by depressing pendant paddles.
2. Remove brake end cover.
3. Before adjusting the gap, back off the brake nuts and examine friction linings and friction surfaces for wear, scoring or warpage (min.thk. .188). Any of these symptoms indicate the need for replacement of parts.
4. Turn brake nuts clockwise gaging the air gap on all three posts..
5. Replace cover, turn on air supply and check operation.

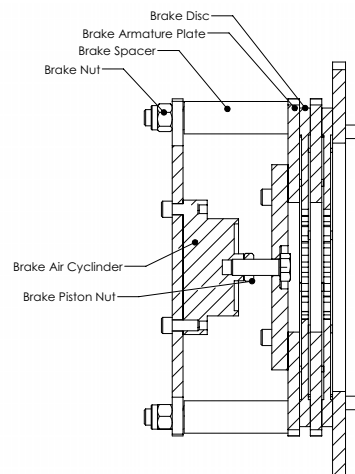

**TROLLEY BRAKE (2 THRU 7½ TON UNITS)
(Optional Accessory)**

Horton/Nexen Brake Information:

The brake can be ordered with the trolley or it is available in kit form for installation on a unit in the field.

To order a brake kit for an existing unit, contact sales and indicate the serial number of the trolley on which it is to be installed.

RECOMMENDED SPARE PARTS

To insure continued service of the XL Air Hoist, the following is a list of parts that are recommended to be kept on hand at all times to replace parts that have worn. Parts applicable to your unit should be stocked.

Key No.	Part Name	Qty for Each Hoist in Service
652-131	Brake Friction Disc	2
652-307	Valve O-Ring Kit	1
652-308	Motor Repair Kit	1

Refer to page 22 thru 39 for ordering instructions and the parts list for part numbers.

PREVENTIVE MAINTENANCE

In addition to the inspection procedure on page 12, a preventive maintenance program should be established to prolong the useful life of the hoist and maintain its reliability and continued safe use. The program should include the periodic and frequent inspections with particular attention being paid to the lubrication of the various components using the recommended lubricants (see page 14).

 WARNING
Components such as motors, valves, lines, filter/lubricators located after a closed shut-off value can contain pressurized air. Disassembly in this state can cause injury.
Bleed the stored air by repeatedly depressing the pendant paddles.

TROUBLE SHOOTING

TROUBLE	PROBABLE CAUSE	REMEDY
1. Hoist does not operate.	<ul style="list-style-type: none"> a. Insufficient air pressure at source. b. Insufficient air supply at hoist c. Clogged air intake filter or muffler. d. Excessive overload e.. Clogged spool valve. f. Clogged pendant throttle control. g. Motor failure. h. Lack of lubrication. i. Brake not operating 	<ul style="list-style-type: none"> a. Check and adjust air pressure. b. Use correct size air supply hose. c. Shut off air supply, disconnect air supply hose and clean air filter and muffler. d. Reduce load to the rated capacity of the hoist. e. Disassemble and check for free movement of spool and condition of o-rings. (see page 18, 19) f. Disassemble and check parts g. Disassemble motor and check rotor vanes (see page 19 ,20) h. Make sure there is oil in the lubricator. i. Make sure the air tubing to the brake is not kinked or pinched. Disassemble brake and check for worn or damaged parts. Check brake adjustment as described on page 14.
2. Hoist will not hold suspended load.	<ul style="list-style-type: none"> a. Brake not holding. b. Broken brake spring. c. Excessive overload. 	<ul style="list-style-type: none"> a. See item 1 (i) b. Replace spring. c. See item 1 (d)
3. Hook will raise but will not lower or hook will lower but not raise	<ul style="list-style-type: none"> a. Clogged pendant throttle control. b. Clogged spool valve c. Excessive load. d. Clogged brake shuttle valve. 	<ul style="list-style-type: none"> a. See item 1 (f) b. See item 1 (e) c. See item 1 (d) d. Clean shuttle valve
4. Hoist loses power.	<ul style="list-style-type: none"> a. Insufficient air pressure. b. Clogged spool valve. c. Clogged muffler. d. Worn or broken rotor vanes. 	<ul style="list-style-type: none"> a. See item 1 (a) b. See item 1 (e) c. Clean or replace muffler. d. Replace worn or damaged rotor vanes (see page 19, 20)
5. Pendant throttle control levers do not return to off position.	<ul style="list-style-type: none"> a. Foreign material, rust or corrosion in pendant throttle control, levers bent or lever pivot pin bent. 	<ul style="list-style-type: none"> a. Clean pendant throttle control and replace worn or damaged parts.
6. Cannot regulate speed using the pendant throttle control levers.	<ul style="list-style-type: none"> a. Brake not operating properly. b. Pendant throttle control not operating properly. 	<ul style="list-style-type: none"> a. See item 1(i) b. See item 5.
7. Lifting and lowering speeds differ from rated speeds.	<ul style="list-style-type: none"> a. Incorrect air pressure or inadequate air supply. b. Loss of power. 	<ul style="list-style-type: none"> a. Check air pressure at hoist when hoist is operating. b. See item 1 (b)
8. Hook does not stop promptly.	<ul style="list-style-type: none"> a. Brake slipping. b. Excessive load. c. Protector slipping. d. Clogged quick release valve. 	<ul style="list-style-type: none"> a. Check brake adjustment as described on page 15. Check for worn parts. b. Reduce loading to the capacity limit of hoist as indicated on the identification plate. c. If protector is not functioning properly, it should be replaced. d. Check for air blast from value when

NOTE: The operation of the trolley motor, valve, and pendant is the same as for the hoist. Items 1,3,4,5,and 7 also refer to trolley maintenance.

HOIST DISASSEMBLY

Refer to pages 24 through 39 for exploded views and parts list. The following are general guide lines for disassembling the XL Air Hoist. Prior to disassembly:

1. Remove the dead end stop (652-304). Remove the chain container.
2. Carefully run the chain out of the hoist. On 3 and 5 ton (double reeved) units, the chain will remain suspended from the dead end block (652-204).
3. Disconnect the hoist from the air supply system and Lockout/Tagout disconnecting means.

WARNING

Components such as motors, valves, lines, filter/lubricators located after a closed shut-off value can contain pressurized air. Disassembly in this state can cause injury.

Bleed the stored air by repeatedly depressing the pendant paddles.

4. Drain the oil from the hoist.
5. Remove the hoist from its support (hook suspended units) or remove the hoist and trolley from the beam. Remove the trolley from the hoist.

These guide lines cover the disassembly of the major mechanical components; not covered is the removal of obvious items such as hardware and seals. While disassembling the hoist, care should be taken so as to not damage the seals. Seals should be inspected for nicks or damage that could cause oil leaks. Damaged seals should be replaced prior to reassembly.

1. Remove brake end cover (652-181).
2. Remove the brake assembly (652-161) and brake hub (652-142).
3. Remove the motor end cover (652-182) and the complete motor (652-162). Coupling (652-103) should remain on motor shaft.
4. On the 2, 3 and 5 ton units, remove chain plate (652-178). On the 6 and 7 1/2 ton units, remove the idler wheel housing (652-211) with idler wheel and bearings.
5. *Remove the brake housing (652-108) and gasket (652-118).
6. Remove the drive shaft and pinion (652-112).
7. Remove the Protector (652-160).
8. *Remove the intermediate plate (652-109) from the main housing (652-110) and remove gasket (652-118).

9. Remove the limit switch gear (652-149) from the limit switch input shaft (652-104) and remove the shaft from the intermediate plate.
10. Remove the second gear (652-159) from third reduction pinion and shaft (652-106) and remove the third reduction pinion and shaft from the main housing (652-110).
11. Remove the liftwheel gear (652-105) from the liftwheel (652-111).
12. Remove the motor housing (652-107) from the main housing (652-110).
13. Remove the chain stripper (652-114) and chain guide (652-113).
14. On the 3, and 5 ton (Double Reeved) units, remove the dead end block (652-204) and chain.
15. Remove the liftwheel (652-111) from the main housing.

*Slots are provided in the intermediate plate (652-109) to aid in the removal.

HOIST REASSEMBLY

The reassembly of the hoist is, basically, the reverse of the above disassembly sequence. However, during reassembly:

1. If new seals are installed, make sure the lip of the seal is on the oil side.
2. Apply a light coat of gear oil to lips of all seals and surfaces of shafts that pass thru the seals.
3. Carefully slide the shafts through the seals.
4. The frame screws used to attach the motor and gear housings to the main frame should be tightened to a seating torque of 21 pound feet (28 NM).
5. Lubricate, especially the splines, as specified on page 14.
6. Make sure that "this side out" embossed on the liftwheel gear is visible when the gear is assembled to the liftwheel.
7. Place the load chain (with welds down and towards liftwheel. See illustration on page 20) over the liftwheel before attaching the motor housing to the main frame. After assembly reeve the chain per page 20.
8. Follow the instructions starting on page 4 when re-installing the unit.
9. After installation, test the unit as indicated on page 22.

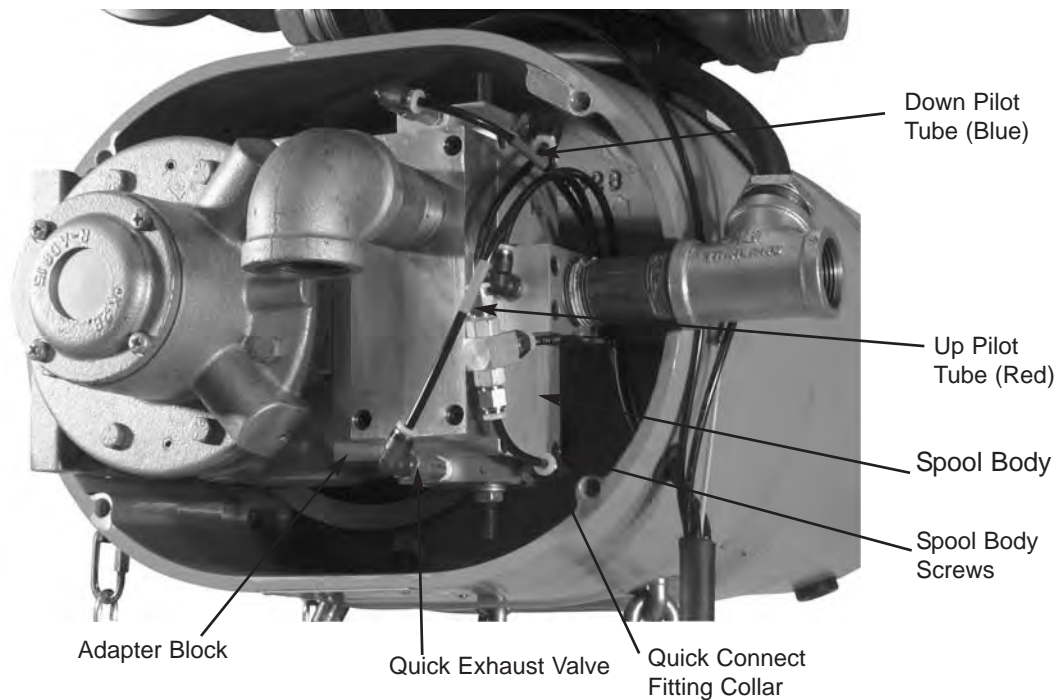

Motor End View

VALVE DISASSEMBLY

1. Turn off the air supply and bleed off the stored air by repeatedly depressing the pendant paddles.
2. Disconnect the five air lines (3/16" dia.) by pushing the plastic collars toward the body of the quick connect fittings and pulling on the 3/16" diameter tube.
3. Remove the (4) attaching bolts for the spool body.
4. Remove the (4) attaching bolts for the adapter block.
5. Remove the intake, exhaust, and spool end block by removing the (4) socket head cap screws in each block. Remove and discard the o-rings from under each block.
6. Push the spool out of the spool body. Pull the (9) o-rings radially from the slots of the spool using a sharp dental pick. **DO NOT PRY AGAINST THE EDGE OF THE SLOTS.** Narrow faced diagonal cutters can be used to cut the o-ring to aid in removal but do not contact the edge of the slots.
7. Remove the spool end caps using an arbor press and snap ring pliers with right angle tips. **CAUTION:** The end caps are under spring tension, therefore pressure from the arbor press must be applied when removing the retaining rings.
8. Clean all parts in a mild solvent or detergent. Examine the O.D. of the spool and the I.D. of the spool body. If these surfaces have been scored by debris, the valve should be replaced because the o-ring will not seal against a gouged surface.

VALVE REASSEMBLY

1. Lubricate the return end caps, springs, and spool cavity with a layer of EP grease as listed on page 14. Be sure the vents on the end caps are exposed. Compress the springs and caps with an arbor press and install the retaining ring.
2. Install the new spool o-rings from kit 653-307. Start from either end and work inward. Apply a coating of 10W machine oil to the spool and slots for easier assembly. The 70 durometer (softer) o-rings are inserted into the two end slots. The 90 durometer (harder) o-rings are inserted into slots 2 thru 8. These slots are narrower at the top for retention of the o-rings and require special assembly. An o-ring has a flash line or lip at the I.D. and O.D. Roll an o-ring adjacent to the slot and align the outer lip. If the o-ring is twisted it will cause the spool to stick in the body and give less slow speed control. Grab the o-ring on opposite sides of the spool and slide into the slot. Roll the spool on a clean hard surface to push the o-ring into the slot. Again; oil the spool assembly and bore of the spool body and assemble components.
3. Insert new o-rings under the various blocks and assemble to the spool body, motor, and adapter block. Tighten the screws to 90 in-lbs. torque.
4. Reassemble the (5) control lines as shown in the picture.

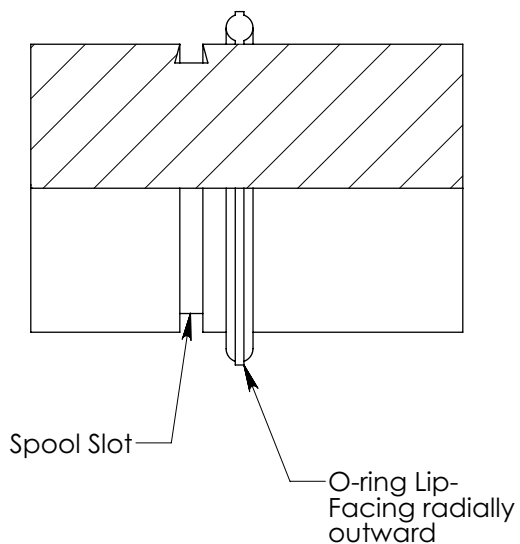
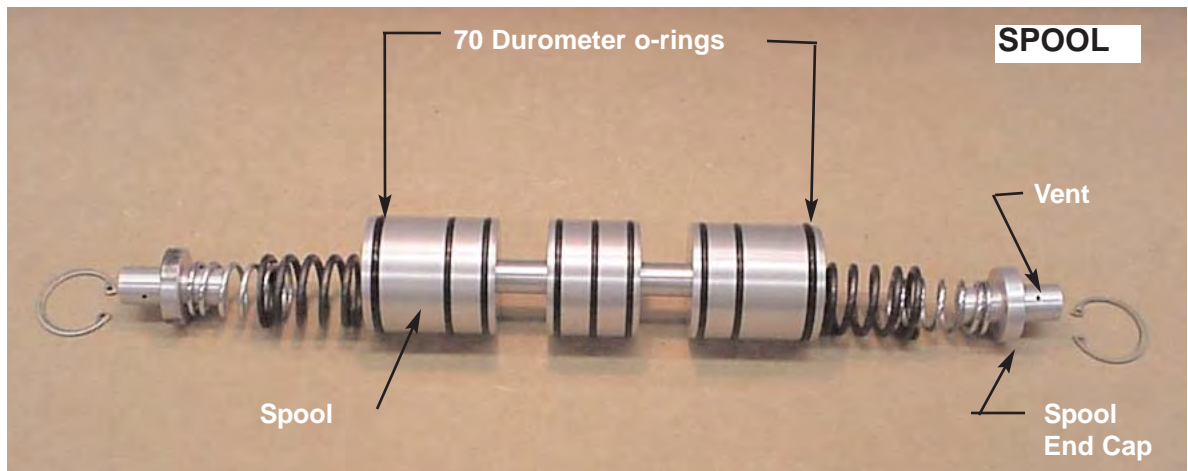
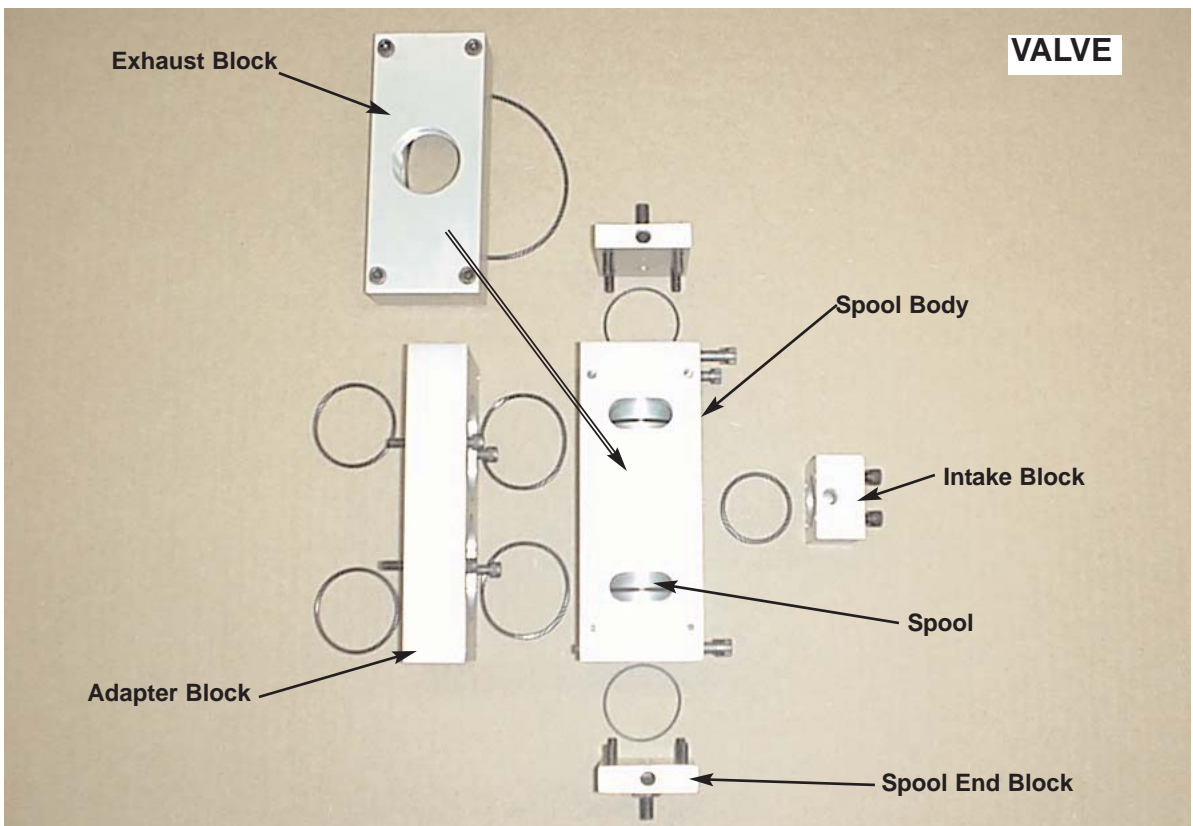

MOTOR REBUILD

(see exploded view, page 39)

- 1 Remove the end cap.
- 2 Remove the dead end plate bolts
- 3 Remove the dead end plate. Do not use a screwdriver to remove the end plate.
- 4 Remove the dowel pins from the body and push them back into end plate until flush or just below the machined surface of the dead end plate.
- 5 Remove the rotor using an arbor press.
- 6 Remove the vanes and ejection mechanisms. (Ejection mechanism consists of vane springs and pins).
- 7 Remove the shaft seal and bearings from the drive end plate. Remove the bearing from the dead end plate.
8. Do Not remove drive end plate bolts or drive end plate.
- 9 Clean parts. Check for scoring on the end plates and rotor assembly. If scoring exists, contact factory.
- 10 Install the push pins.
- 11 Place the drive shaft of the rotor assembly through the drive end plate. Press the drive bearing onto the drive shaft.
12. Lightly tap on the inner race of the drive end bearing to snug up the rotor to the drive end plate.

13. Install the vane spring lip into the notch at one end of the vane and place in the rotor vane slot with the spring facing the pushpin.
14. Place the proper end plate gasket on the body of the dead end. If the original is damaged, replace with a new one supplied in the service kit. If your air motor uses O-rings, place the new O-rings in the body groove.
15. Place the dead end plate on the body.
16. Install the dead end bearing and press into place with the bearing pusher tool from the tool kit.
17. Install the dowel pins.
18. Fully tighten the remaining bolts to 75-100 in-lbs.
19. Set the end clearance as required by model (.0060/.1524).
20. Apply a small amount of grease to the bearing seal and install the drive end bearing seal by pressing it flush with the bearing.
21. Reattach the end cap.
22. Apply a few drops of lubricant into ports and rotate the shaft by hand for a few rotations.

REMOVAL AND REPLACEMENT OF LOAD CHAIN

USE ONLY CM LOAD CHAIN AND FACTORY REPLACEMENT PARTS. USE OF OTHER CHAIN AND PARTS MAY BE DANGEROUS AND VOIDS FACTORY WARRANTY.

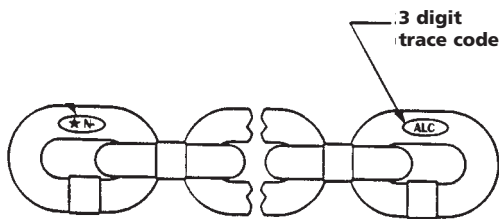

⚠ WARNING
USE OF COMMERCIAL OR OTHER MANUFACTURERS' CHAIN AND PARTS TO REPAIR XL AIR HOISTS MAY CAUSE LOAD LOSS
TO AVOID INJURY:
Use only factory supplied replacement load chain and parts. Chain and parts may look alike, but factory chain and parts are made of specific material or processed to achieve specific properties.

Hoist load chain can be removed and installed using one of the following methods. Method 1 is recommended if only the load chain is replaced. Method 2 is recommended when the entire hoist is disassembled for repair and /or inspection.

METHOD 1

1. Remove the chain container or remove the loose end of the chain from the hoist frame.
2. Using the procedures described on page 28 for cutting load chain, cut a portion out of the last loose end link to form a coupling link. The portion removed should be centered on the weld and be 1/2 inch (13mm) long. Remove burrs from cut edges.
3. Using the coupling link, attach the new chain to the

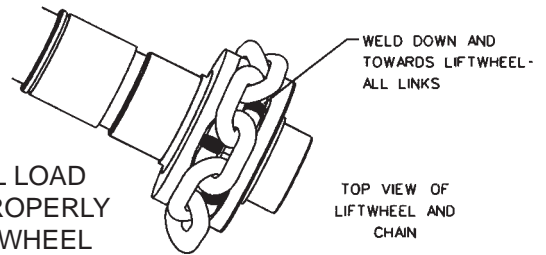

INSTALL LOAD CHAIN PROPERLY ON LIFTWHEEL

⚠ WARNING
Improper installation (reeving) of load chain can result in dropped load.
TO AVOID INJURY:
Properly reeve load chain per the following instructions.

old chain. Carefully check the welds on the new chain and make sure they are positioned the same as the old chain. The new chain must enter the hoist so that the welds are down and towards the lift wheel. See illustration above. Failure to properly position the chain will cause the chain to jam between the liftwheel and chain guide.

4. Operate the hoist in the "down" direction until approximately 6 feet (2 M) of the new chain is hanging free on the dead end side.
5. ON SINGLE REEVED UNITS, remove the hook block from the old chain, remove the coupling link, discard the old chain and attach the hook block to the new chain. ON DOUBLE REEVED UNITS, the hoist must be removed from the trolley before reeving the replacement load chain. For hook suspended units, the hook must be positioned so that the dead end bolt can be removed. If necessary, rotate hook approximately 45 degrees following the instructions on page 5. Now remove the chain plate and allow it and the dead end block spacer (652-253) to slide down the chain. Working through the cavity in the bottom of the hoist, hold the dead end block while loosening the dead end bolt. Remove the dead end block and remove the dead end pin. Remove the coupling link, pull the old chain out of the hook block and discard the old chain. Reeve the new load chain as described below. After reeving, mount the trolley on the hoist or reposition the hook, if necessary, per installation instructions starting on page 4. ON TRIPLE REEVED UNITS, remove the dead end plate from the top of the hook block. Remove the dead end pin and remove the old chain from the dead end plate. Remove the coupling link, pull the old chain out of the hook block and idler sheave housing. Reeve the new load chain as described below.
6. Remount the chain container or reattach the loose end of the new chain to the hoist.

METHOD 2

1. Completely disassemble the hoist as described on page 26.
2. Prior to reassembly, inspect the liftwheel, chain guides and stripper for wear. If these parts are worn or damaged, they could cause premature wear of the chain. Replace worn or damaged parts.
3. Place chain on liftwheel with welds down and towards liftwheel as shown below. Welds must engage the relief machined in the bottom of the

liftwheel pockets. If the chain is not properly placed on the liftwheel, it will not be possible to install the chain guide. After making sure the chain is correctly installed on the liftwheel, continue to assemble the hoist.

4. On single reeved units, remove the hook block from the old chain and attach it to the new chain. On double and triple reeved units, reeve the new chain as described below.
5. Install the unit following the installation instructions starting on page 4.
6. Remount the chain container or reattach the loose end of the new chain to the hoist frame.

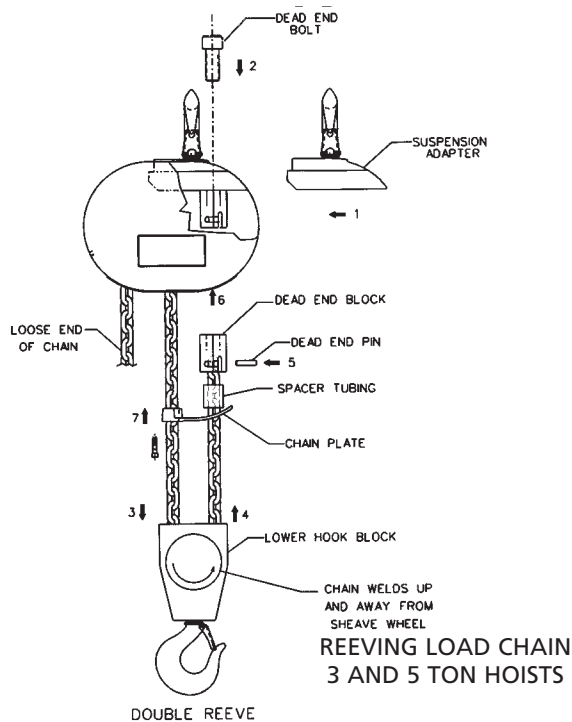

HOOK SUSPENSION SHOWN. LUG SUSPENSION SIMILAR

REEVING LOAD CHAIN

3, AND 5 TON DOUBLE REEVED UNITS

The following instructions assume that the trolley has been removed from the hoist or the upper hook has been positioned to provide access to the dead end bolt and that there is 6 feet (2 m) of chain hanging free on the dead end side of the hoist. Based on these, reeve the load chain as follows:

1. Slide the suspension adapter into the hoist frame, if has moved out of position or if it was removed.
2. Install the dead end bolt.
3. Attach a soft wire to the dead end of the chain. Feed the wire around the hook block sheave. **MAKING SURE THERE ARE NO TWISTS**, pull the chain thru the hook block.
4. Feed the chain thru the square opening in the chain plate and then thru the dead end block spacer.
5. Attach the last link of chain to dead end block using the dead end pin.
6. **MAKING SURE THERE ARE NO TWISTS IN THE CHAIN**, slide the dead end block into the cavity in

hoist frame. Turn the dead end bolt by hand to thread it into the dead end block. Then tighten dead end bolt to a seating torque of 120 pound feet (160 NM).

7. Slide the chain plate and spacer up the chain and attach the chain plate to the hoist frame.
8. Retrace the chain and make sure there are no twists. If there are twists, start over.

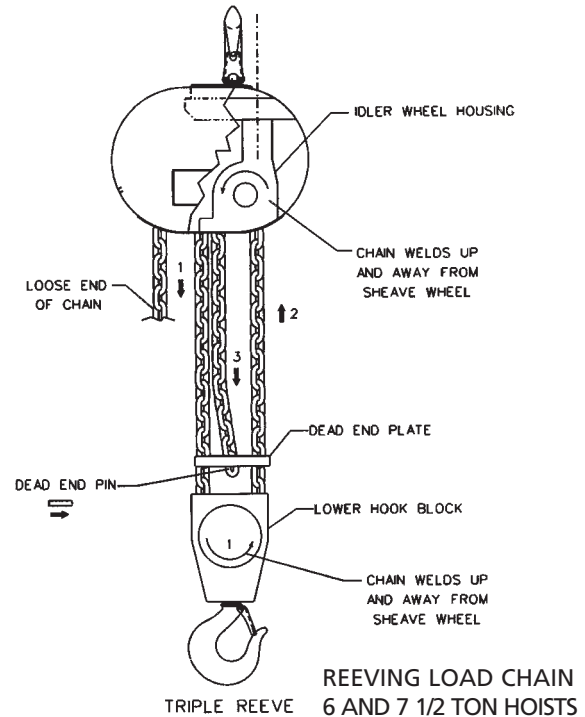

HOOK SUSPENSION SHOWN. LUG SUSPENSION SIMILAR
6 AND 7 1/2 TON TRIPLE REEVED UNITS

The following instructions assume that the idler wheel housing assembly has been attached to the suspension adapter and hoist frame, there is 6 feet (2 M) of chain hanging free on the dead end side of the hoist and the hoist is suspended from the trolley or permanent support.. Based on these, reeve the load chain as follows:

1. Attach a soft wire to the dead end of the chain. Feed the wire around the lower hook block sheave. **MAKING SURE THERE ARE NO TWISTS IN THE CHAIN**, pull the chain thru the hook block.
2. Feed the soft wire into the outboard side of the idler wheel housing and around the idler wheel. **MAKING SURE THERE ARE NO TWISTS IN THE CHAIN**, pull the chain over the idler wheel.
3. Remove the wire from the end of the chain and route chain down to the hook block. **MAKING SURE THERE ARE NO TWISTS IN THE CHAIN**, insert the last link of the chain into the slot in the dead end plate. Secure the chain using the dead end pin and attach the dead end plate to top of hook block. Tighten the dead end plate screws to a seating torque of 120 pound feet (160 NM).
4. Retrace chain and make sure there are no twists. If there are twists, start over.

CUTTING CHAINS

Hoistaloy® load chain is hardened and it is difficult to cut. The following methods are recommended when cutting a length of new chain from stock or cutting off worn chain. Always wear eye protection when cutting chain.

1. Use a grinder and nick the link on both sides (see below), then secure the link in a vise and break off with a hammer.

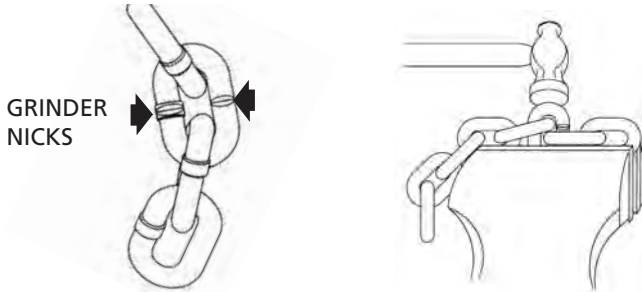

Cutting Chain by Nicking

2. Use a 7 inch (177 mm) minimum diameter by 1/8 inch (3.1 mm) thick abrasive wheel (or type recommended by wheel supplier) that will clear adjacent links.
3. Use a bolt cutter (See below) similar to the H.K. Porter No. 0590MTC with special cutter jaws for cutting hardened chain. Jaws should be 1 inch (25.4 mm) long.

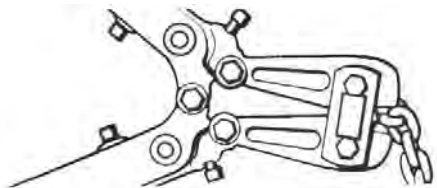

Cutting Chain with a Bolt Cutter

⚠ WARNING

Cutting Chain Can Produce Flying Particles.

TO AVOID INJURY:

- Wear Eye Protection
- Provide A Shield Over Chain To Prevent Flying Objects

TESTING

Before using, all altered, repaired or used hoists that have not been operated for the previous 12 months shall be tested by the user for proper operation. First, test the unit without a load and then with a light load of 50 pounds (23 kg) times the number of load supporting parts of load chain to be sure that the hoist operates properly and that the brake holds the load when control is released. Next test with a load of *125% of rated capacity. In addition hoists in which load sustaining parts have been replaced should be tested with *125% of rated capacity by or under the direction of an appointed person and written report prepared for record purposes. After this test, check that the Protector functions. If the Protector permits lifting a load in excess of 200% of rated load, it should be replaced.

NOTE: For additional information on inspection and testing, refer to American National Standard ASME B30.16 "Overhead Hoists" obtainable from The American Society of Mechanical Engineers, 345 East 47th Street, New York, NY 10017 U.S.A.

*If the Protector prevents lifting of a load of 125% of rated capacity, reduce load to rated capacity.

REPAIR PARTS

ORDERING INSTRUCTIONS

The following information must accompany all correspondence and orders for replacement parts:

1. Hoist rated load from identification plate.
2. Serial number of the hoist stamped below identification plate.
3. Length of lift.
4. Key number of part from the parts list.
5. Number of parts required.
6. Part name from the parts list.
7. Part number from the parts list.

If trolley replacement parts are ordered, also include the type and capacity of the trolley.

NOTE: WHEN ORDERING REPLACEMENT PARTS, IT IS RECOMMENDED THAT CONSIDERATION BE GIVEN TO THE NEED FOR ALSO ORDERING SUCH ITEMS AS GASKETS, FASTENERS, INSULATORS, SEALS, ETC. THESE ITEMS MAY BE DAMAGED OR LOST DURING DISASSEMBLY OR JUST UNFIT FOR FUTURE USE BECAUSE OF DETERIORATION FROM AGE OR SERVICE.

⚠ WARNING

Using "commercial" or other manufacturer's parts to repair XL Air Hoists may cause load loss.

TO AVOID INJURY:

Use only factory supplied replacement parts. Parts may look alike but factory original parts are made of specific materials or processed to achieve specific properties.

Repair Parts

Hoists that have been in service for a long period or under adverse conditions may require disassembly for adjustment and replacement of parts. The drawings on the following pages are of the exploded type to indicate order of assembly and relative position of parts. The parts list opposite each drawing includes a key number for each part. These key numbers appear on each drawing connected to the appropriate parts

Contents: no.	Page
1. Hoist Arrangement	24-25
2. Brake Components	26-27
3. Motor Components	28-29
4. Gearing Components	30-31
5. Liftwheel and Suspension components	32-33
6. Two Ton Plain and Geared Trolley	34-35
7. 2 Ton MDT, 3-7 1/2 Ton Trolley	36-37
8. 2 thru 7 1/2 Ton MDT Motor and Gearbox	38
9. Hoist Air Motor	39

Important

When referring to your hoist in correspondence or repair kit part orders, always give the model number from the hoist identification plate and the serial number which is stamped on the motor housing directly below

Part Number for Packaged Lubricants Used in the XL Air Chain Hoist (Refer to page 14 for Lubrication Instructions)		
Lubricant Usage	Type of Lubricant	Part Numbers and Packaged Quantity of Lubricants
Hoist Gears	Hulbest EP ISO VG 68 thru 460 (H-2)	52776 for 1 Gal. Can
Splines	*Grease	EP Type Grease - Obtain Locally
Load Chain	Oil	28608 for 1 Pint Can 28619 for 1 Gal. Can
Lower Hook Thrust Bearing	*Oil	Heavy Machine Oil Obtain Locally
Trolley Trackwheel Bearings and Gears	Grease (Novatex #2)	28632 for 4 lb. Can 28610 for 1 lb. Can
Trolley Gears	Grease (Novatex #1)	28613 for 4 lb. Can 28612 for 1 lb. Can

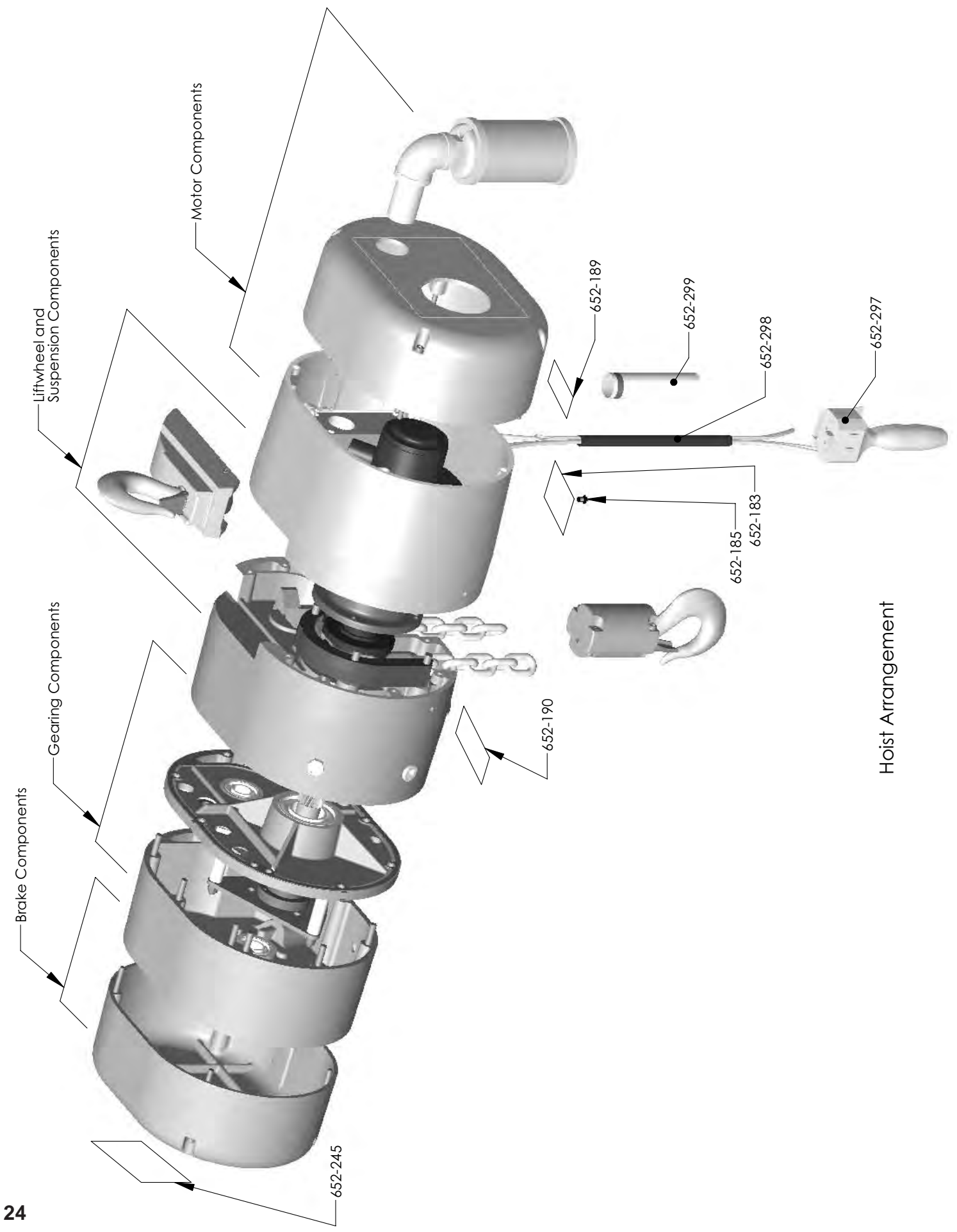

Hoist Arrangement

Key No.	No. Req'd	Part Name	Part No.
652-183	1	Identification Plate Lodestar XL Budgit XL Coffing XL	70728 70736 53035
652-185	4	I.D. Plate Drive Screw	988271
652-189	1	Capacity Label 2 Ton 3 Ton 5 Ton 6 Ton 7 1/2 Ton	52714 52724 52726 52728 52757
652-190	1	Warning Label 2 Ton 3 Ton 5 Ton 6 Ton 7 1/2 Ton	52715 52725 52726 52728 52785
652-245	1	Lodestar XL Label Budgit XL Label Coffing XL Label	52760 52782 53036
652-297	1	Control Pendant without MDT (2 paddle) with MDT (4 paddle)	53020 22825502
652-298	1	Control Cable without MDT with MDT For 10' Lift. For other lifts contact CM	53025 53037
652-299	1	Warning Tube	687J6

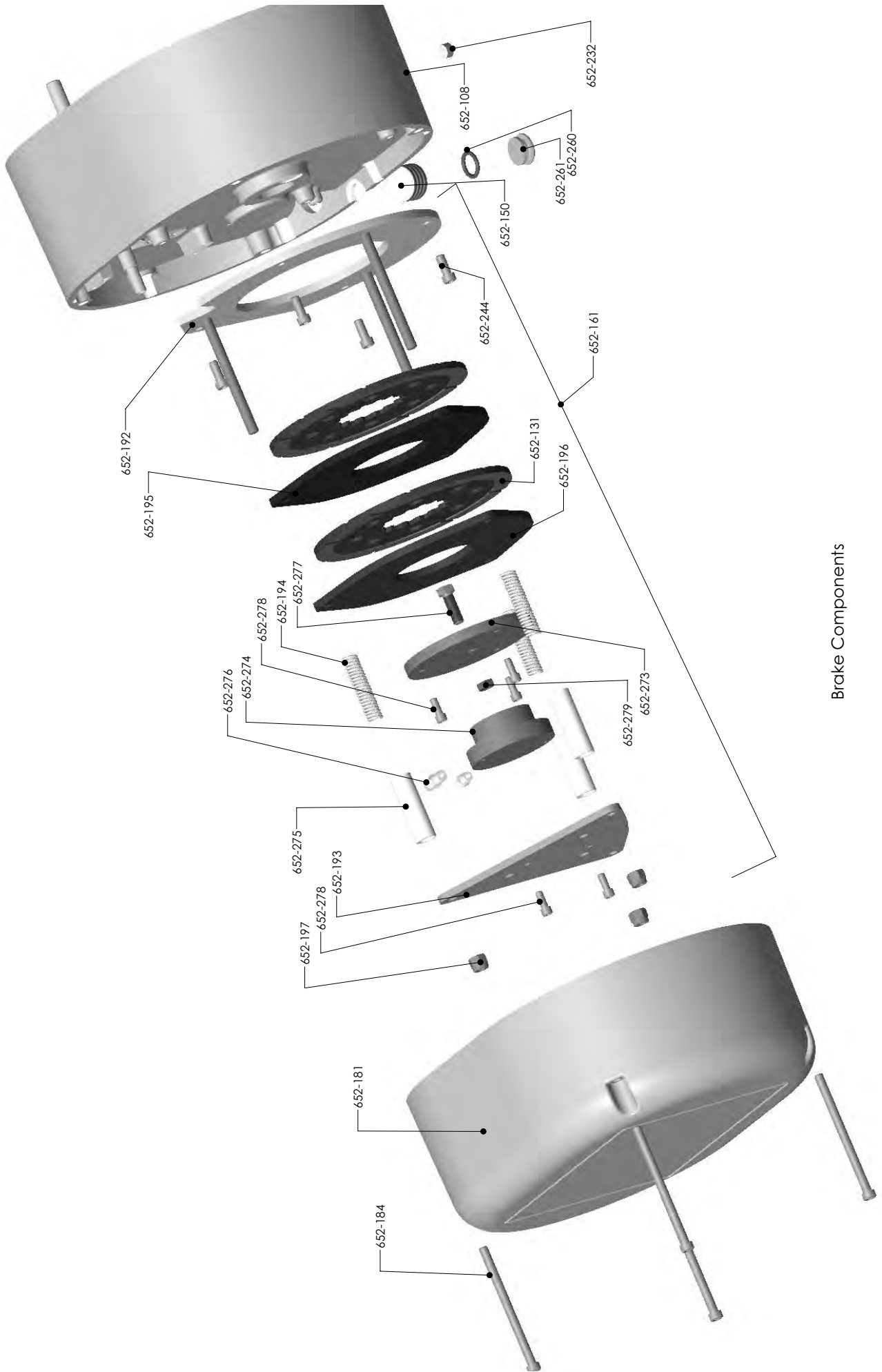

Brake Components

Brake Components

Key No.	No. Req'd	Part Name	Part No.
652-108	1	Brake Housing Assembly	52632
652-131	2	Brake Friction Disc	70652
652-150	1	Frame Plug (1")	989074
652-161	1	Air Brake Complete	53026
652-181	1	Brake End Cover	52028
652-184	4	Brake End Cover Screw	80409
652-192	1	Brake Base Plate	52607
652-193	1	Brake Field Plate	53008
652-194	1	Brake Spring Kit (3 springs total for brake assembly)	53044
652-195	1	Brake Intermediate Plate	68820
652-196	1	Brake Armature Plate	53007
652-197	3	Brake Nut	982448
652-232	1	Drain Plug	989050
652-244	4	Brake Attaching Screw	946801
652-260	1	Control Grommet O-Ring	52778
652-261	1	Control Grommet	52777
652-273	1	Brake Retaining Plate	53004
652-274	1	Air Cylinder	53005
652-275	3	Brake Spacer Tube	53006
652-276	1	Breather, Brake	53011
652-277	1	Screw, Brake	53029
652-278	5	Screw, Brake Air Cylinder Att'g	53017
652-279	1	Nut Brake Piston	988230

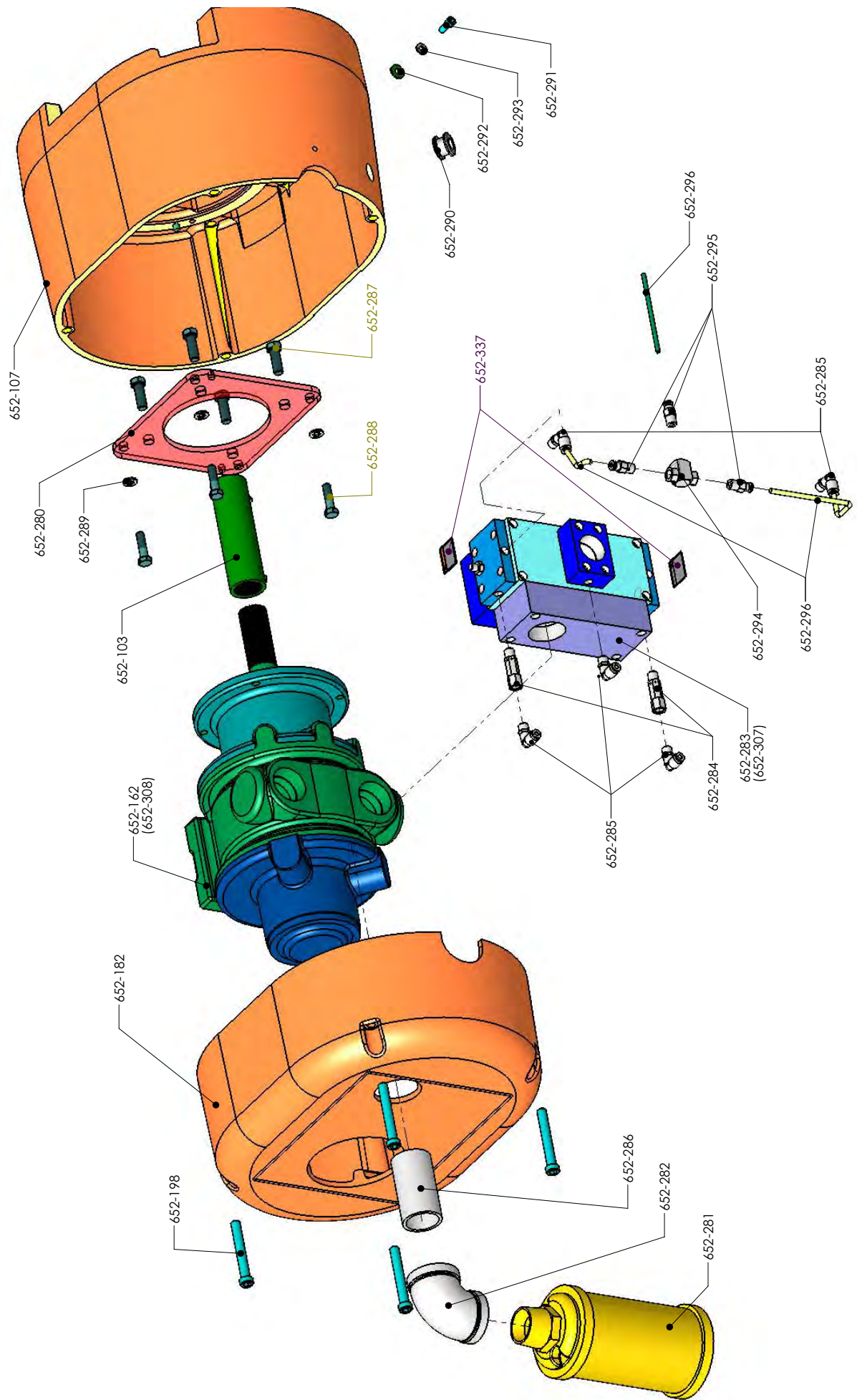

Motor Components

Key Number	No. Req'd	Part Name	Part Number
652-103	1	Motor Shaft Coupling	52078
652-107	1	Motor Housing Assembly	53019
652-162	1	Air Motor	53002
652-182	1	Motor End Cover	53012
652-198	4	Motor Cover Screw	80409
652-280	1	Motor Adapter Plate	53009
652-281	1	Muffler	53014
652-282	1	Muffler Connecting Elbow	53027
652-283	1	Bi-Directional Valve	53003
652-284	2	Quick Exhaust Valve	53016
652-285	5	Fitting, Male 90 Deg. Elbow	53021
652-286	1	1 1/4 Pipe Nipple Galvanized	53028
652-287	4	Motor Screw	982597
652-288	4	Motor Plate Screw	987210
652-289	4	Motor Plate Lockwasher	945851
652-290	1	Grommet	53013
652-291	1	Strain Loop Screw	53017
652-292	1	Strain Loop Washer	927835
652-293	1	Strain Loop Lockwasher	982226
652-294	1	Shuttle Valve	53015
652-295	3	Fitting, Straight	53018
652-296	A/R	3/16 Nylon Tubing	53023
652-307	1	Valve O-ring Repair Kit	53033
652-308	1	Motor Repair Kit (See page 39)	53034
652-337	2	Warning Label, Spool Stop	53043

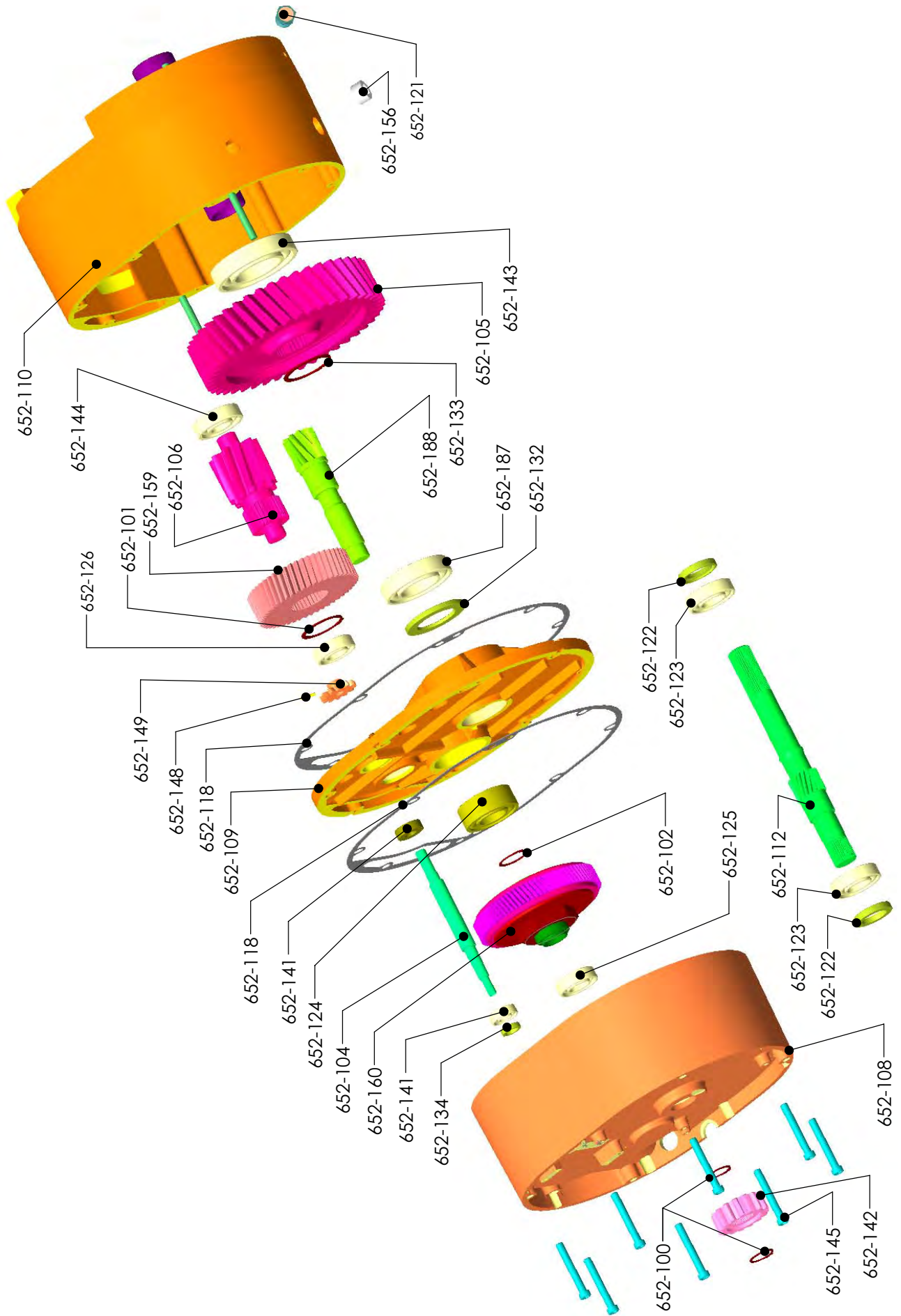

Gearing Components

Key No.	No. Req'd	Part Name	Part Number
652-100	2	Brake Hub Snap Ring	35764
652-101	1	2nd Gear Snap Ring	36763
652-102	1	2nd Pinion Snap Ring	45766
652-104	1	Limit Switch Input Shaft	52019
652-105	1	Liftwheel Gear	52021
652-106	1	3rd Reduction Pinion and Shaft	52026
652-108	1	Brake Housing Assembly	52632
652-109	1	Intermediate Plate Assembly	52633
652-110	1	Main Housing Assembly	52630
652-112	1	Drive Shaft and Pinion	52079
652-118	2	Main Housing Gasket	52709
652-121	1	Breather	70726
652-122	2	Drive Shaft Seal	80401
652-123	2	Drive Shaft Bearing	80402
652-124	1	2nd Reduction Pinion Bearing - Inboard	80403
652-125	1	2nd Reduction Pinion Bearing- Outboard	80404
652-126	1	3rd Reduction Pinion Bearing - Outboard	80408
652-132	1	Liftwheel Seal - Inboard	80415
652-133	1	Liftwheel Gear Snap Ring	80416
652-134	1	Limit Switch Input Shaft Seal	80417
652-141	2	Limit Switch Input Shaft Bearing	88437
652-142	1	Brake Hub	68367
652-143	1	Liftwheel Bearing-Gear End	80413
652-144	1	3rd Reduction Pinion Bearing- Inboard	88500
652-145	15	Frame Screw	987289
652-148	1	Limit Switch Gear Pin	983768
652-149	1	Limit Switch Gear	52713
652-156	2	Frame Plug (3/4")	989055
652-159	1	2nd Gear	52024
652-160	1	Protector Assembly	
		2 Ton, 6 Ton	52614
		3 Ton	52613
		5 ton, 7.5 Ton	52616
652-187	1	Liftwheel Gear Bearing	80414
652-188	1	2nd Reduction Pinion	52023

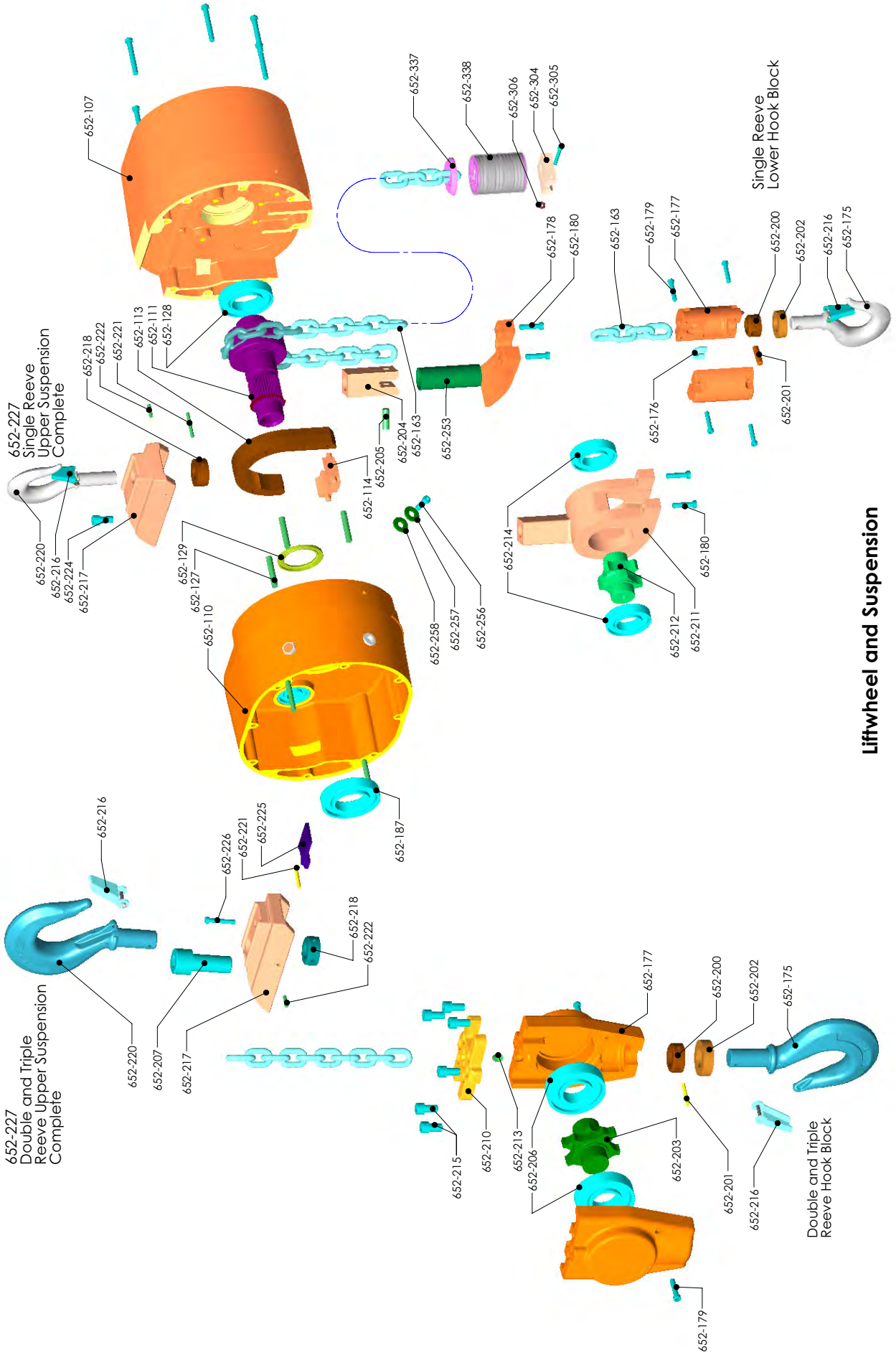

Liftwheel and Suspension

Liftwheel and Suspension

Key No.	No. Req'd	Part Name	Part Number
652-107	1	Motor Housing Assembly	53019
652-110	1	Main Housing Assembly	52630
652-111	1	Liftwheel	52033
652-113	1	Chain Guide	52041
652-114	1	Chain Stripper	52055
652-127	3	Chain Guide Pin	80410
652-128	1	Liftwheel Bearing - Motor End	80411
652-129	1	Liftwheel Seal - Gear End	80412
652-163	1	Load Chain	85885
652-175	1	Lower Hook with Latch: Latch Type: 2 Ton 3,5,6 and 7 1/2 Ton	35612 52651
652-176	1	Lower Hook - Loatchlok Type 2 Ton 3,5, and 6 Ton 3-6 Ton Lower Latchlok Kit	36681 52625 5264
652-177	2	Half Link	52017
652-178	2	Hook Block: 2 Ton 3 and 5 Ton 6 and 7 1/2 Ton	52025 52049 52069
652-179	1	Chain Plate: 2 Ton 3 and 4 Ton	52046 52048
652-180	2	Hook Block Screw: 2 Tond 3 and 5 Ton 6 and 7 1/2 Ton	982369 80423 80423
652-187	1	Chain Plate or Idler Housing Screw	987288
652-200	1	Liftwheel Gear Bearing	80414
652-201	1	Hook Nut or Collar for: 2 Ton 3,5,6 and 7 1/2 Ton	35369 52047
652-202	1	Hook Nut or Collar Pin for 2 Ton 3,5, 6 and 7 1/2 Ton	45946 80418
652-203	1	Lower Hook Thrust Bearing for: 2 Ton 3, 5, 6 and 7 1/2 Ton	88505 80421
652-204	1	Sheave Wheel	52050
652-205	1	Dead End Block	52051
652-206	2	Dead End Pin	52057
		Sheave Wheel Bearing	80422

Key No.	No. Req'd	Part Name	Part Number
652-207	1	Dead End Bolt: 3, 5, 6 and 7 1/2 Ton	80424
652-210	1	Dead End Plate	52068
652-211	1	Idler Wheel Housing	52053
652-212	1	Idler Wheel	52054
652-213	1	Anchor Pin	52058
652-214	2	Idler Wheel Bearing	80425
652-215	6	Dead End Plate Screw	52074
652-216	1	Latch Kit for: 2 Ton 3, 5, 6 and 7 1/2 Ton	45663 52701
652-217	1	Suspension Adapter for: 2 Ton 3,5, and 6 Ton	52022 52035
652-218	1	Upper Hook Nut for: 2 Ton 3,5, and 6 Ton	52045 52047
652-220	1	Upper Hook, Latch Type for: 2 Ton 3,5, 6 and 7 1/2 Ton Upper Hook, Latchlok Type for: 2 Ton 3, 5, and 6 Ton	52608 52651 52624 52625
652-221	1	Hook Nut Pin	80418
652-222	1	Anti-Rotation Pin for: 2 Ton 3, 5, and 6 Ton	80419 80420
652-224	1	Suspension Screw (2Ton Only)	987208
652-225	1	Anti-Rotation Plate	52708
652-226	1	Anti-Rotation Plate Screw	982371
652-227	1	Upper Hook Suspension Latch Type Complete 2 Ton 3, 5, and 6 Ton	5254 5255
652-253	1	Dead End Block Spacer	52064
652-256	1	Loose End Screw	982667
652-257	1	Loose End Screw Washer	987898
652-258	1	Loose End Screw Washer	45915
652-304	1	Dead End Stop	53030
652-305	1	Dead End Stop Screw	982066
652-306	1	Dead End Stop Screw Locking Nut	82638
652-337	1	Snubber Plate	53052
652-338	1	Snubber Block Assembly	53053

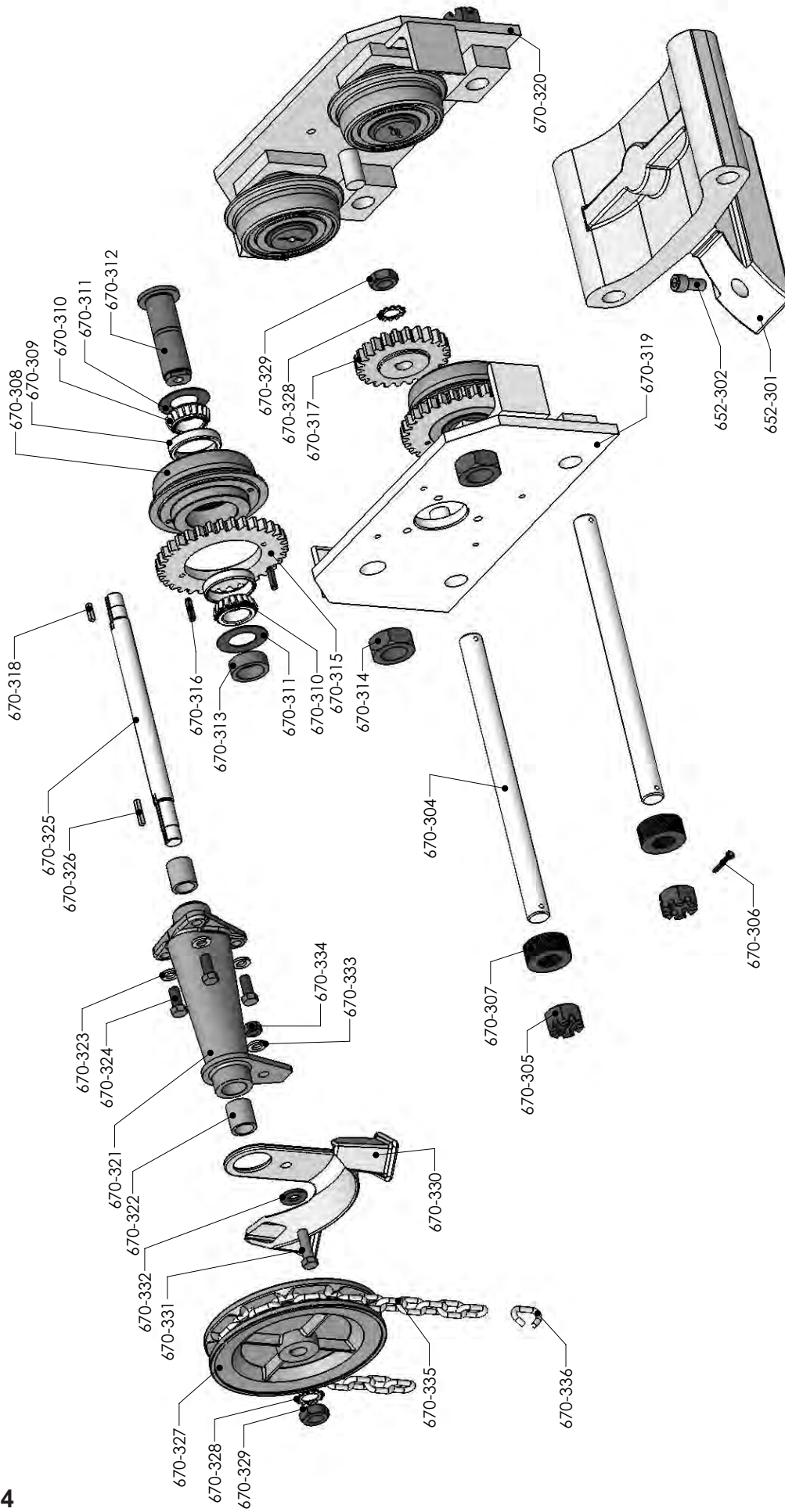

2 TON
PLAIN AND GEARED TROLLEYS
EXPLODED VIEW

**2 Ton
Plain and Geared Trolleys Parts List**

Key No.	No. Req'd	Part Name	Part Number
652-301	1	Hoist Suspension Adapter	52059
652-302	1	Suspension Adapter Screw/Dead End Bolt	987208
670-304	2	Suspension Bolt	58503
670-305	4	Suspension Bolt Nut	958818
670-306	4	Suspension Bolt Nut Cotter Pin	988368
670-307	-	Spacer Washer-Specify No. Req'd	958726
670-308	4	Trackwheel with Bearing Cup	
670-309	8	Trackwheel Bearing Cup	88521
670-310	8	Trackwheel Bearing Cone	88525
670-311	4	Trackwheel Bearing Shield	88525
670-312	4	Trackwheel Stud	68918
670-313	4	Trackwheel Stud Collar	58459
670-314	4	Trackwheel Stud Nut	58484
670-315	2	Trackwheel Gear	982613
670-316	4	Trackwheel Gear Pin	983503
670-317	1	Trackwheel Gear Pinion	58505
670-318	1	Trackwheel Pinion Key	85546
670-319	1	Geared Side Frame	59615

Key Nu.	No. Req'd	Part Name	Part Number
670-320		Plain Side Frame	59614
670-321	1	Handwheel Bracket with Bushings	59616
670-322	2	Handwheel Bushing	58727
670-323	3	Handwheel Bracket Screw L.W.	945853
670-324	3	Handwheel Bracket Screw	987061
670-325	1	Handwheel Shaft	59504
670-326	1	Handwheel Key	59967
670-327	1	Handwheel	33143
670-328	1 or 2	Trackwheel Pinion or Handwheel Shaft Nut L.W.	986270
670-329	1 or 2	Trackwheel Pinion or Handwheel Shaft Nut	988095
670-330	1	Handchain Guide	58152
670-331	1	Chain Guide Screw	987065
670-332	1	Chain Guide Screw Washer	986224
670-333	1	Chain Guide Screw L.W.	945853
670-334	1	Chain Guide Screw Nut	945822
670-335	-	Hand Chain-Specify length req'd	619022
670-336	1	Hand Chain Connecting Link	945491

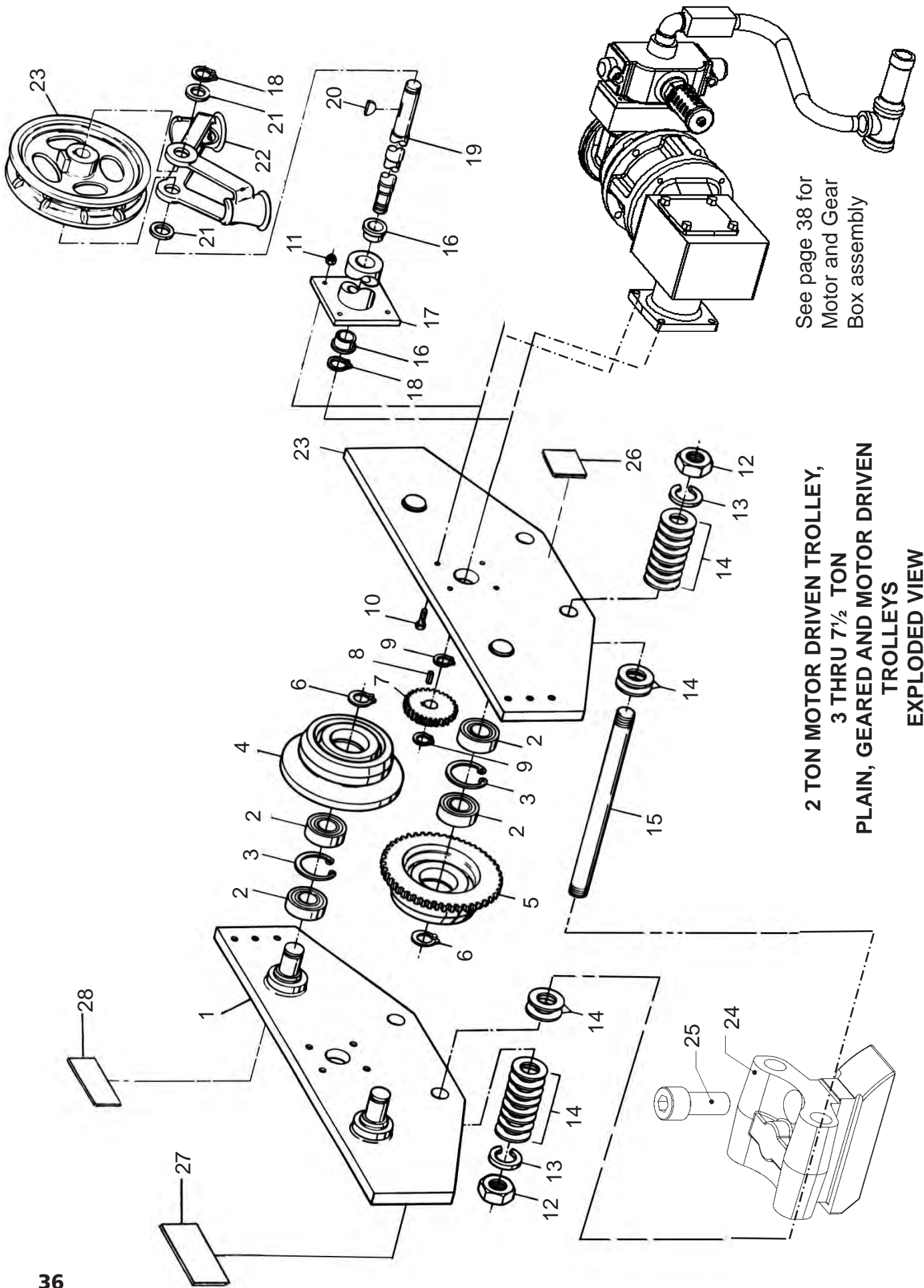

**2 TON MOTOR DRIVEN TROLLEY,
3 THRU 7½ TON
PLAIN, GEARED AND MOTOR DRIVEN
TROLLEYS
EXPLODED VIEW**

REF. NO.	NO. REQ'D	PART DESCRIPTION	PART NUMBER					
			3 TON		2 & 3 TON	5 - 7 1/2 TON		
			PLAIN	GEARED	MOTOR DRIVEN	PLAIN	GEARED	MOTOR DRIVEN
1	2	SIDE PLATE ASSEMBLY FOR:						
		4" TO 6 1/4" FLG. AND PATENTED TRACK	700T-1400	700T-1700	BET-2800	700T-1501	700T-1801	BET-3801
		6 3/8" TO 8 5/8" FLG.	700T-1402	700T-1701	BET-2801	700T-1504	700T-1803	BET-3803
		8 3/4" TO 11" FLG.	700T-1404	700T-1702	BET-2802	700T-1507	700T-1805	BET-3805
2	8	BALL BEARING	700T-1406	700T-1703	BET-2803	700T-1514	700T-1811	BET-3811
3	4	RETAINING RING	700T-1407	700T-1704	BET-2804	700T-1516	700T-1813	BET-3813
4	2	TRACKWHEEL-PLAIN						
		STANDARD	700T-1408	700T-1705	BET-2805	700T-1518	700T-1815	BET-3815
		PATENTED TRACK	700T-1409	700T-1706	BET-2806	700T-1520	-----	BET-3817
		SPARK RESISTANT	700T-1410	700T-1707	----	700T-1521	700T-1818	----
5	2	TRACKWHEEL-GEARED						
		STANDARD	----	700T-1708	BET-2807	----	700T-1820	BET-3818
		PATENTED TRACK	----	700T-1709	BET-2808	----	----	BET-3820
		SPARK RESISTANT	----	700T-1710	----	----	700T-1823	----
6	4	RETAINING RING	700T-1411	700T-1711	BET-2809	700T-1523	700T-1825	BET-3821
7	1	PINION	----	700T-1719	BET-2810	----	700T1846	BET-3823
8	1	PINION KEY	----	700T-1720	BET-2811	----	700T-1847	BET-3824
9	2	**RETAINING RING	----	700T-1718	BET-2812	----	700T-1845	BET-3825
10	4	HEX CAP SCREW	----	700T-1721	BET-2813	----	700T-1848	BET-3826
11	4	SELF LOCKING NUT	----	700T-1725	BET2814	----	700T-1853	BET-3828
12	4	HEX JAM NUT	700T-1412	700T-1712	BET-2815	700T-1526	700T-1828	BET-3830
13	4	LOCKWASHER	700T-1414	700T-1713	BET-2816	700T-1529	700T-1831	BET-3833
14	40	SPACE WASHERS	700T-1416	700T-1714	BET-2817	700T-1532	700T-1834	BET-3836
15	2	SUSPENSION PIN FOR:						
		4" TO 6 1/4" FLG. AND PATENTED TRACK	700T-1418	700T-1715	BET-2818	700T-1535	700T-1837	BET-3839
		6 3/8" TO 8 5/8" FLG.	700T-1420	700T-1716	BET-2819	700T-1537	700T-1839	BET-3841
		8 3/4" TO 11" FLG	700T-1422	700T-1717	BET-2820	700T-1539	700T-1841	BET-3843
16	2	BUSHING	----	700T-1723	----	----	700T-1851	----
17	1	PLATE AND TUBE ASSEMBLY	----	700T-1724	----	----	700T-1852	----
18	2	RETAINING RING	----	700T-1722	----	----	700T-1850	----
19	1	HANDWHEEL SHAFT	----	700T-1726	----	----	700T-1854	----
20	1	HANDWHEEL SHAFT KEY	----	700T-1727	----	----	700T-1856	----
21	2	WASHER	----	700T-1728	----	----	700T-1857	----
22	2	CHAIN GUIDE						
		8 5/8" O.D. HAND CHAIN WHEEL	----	700T-1729	----	----	----	----
		11 5/8" O.D. HAND CHAIN WHEEL	----	700T-1730	----	----	700T-1858	----
23	1	HAND CHAIN WHEEL						
		8 5/8" OUTSIDE DIAMETER	----	700T-1731	----	----	----	----
		11 5/8" OUTSIDE DIAMETER	----	700T-1732	----	----	700T-1860	----
24	1	SUSPENSION ADAPTER	52784			52787		
25	1	SUSPENSION ADAPTER SCREW	80430			80430		
26	1	WARNING LABEL	----	936986		----	936986	
27	1	TROLLEY CAPACITY LABEL	52764			52765		
28	1	WARNING LABEL	936984			936984		
29***	AS REQ'D	HAND CHAIN (NOT SHOWN)						
		STANDARD	----	700T-1733	----	----	700T-1862	----
		SPARK RESISTANT	----	700T-1734	----	----	700T-1863	----
		OPEN LINK (1 REQUIRED)	----	700T-1735	----	----	700T-1864	----

* TOTAL QUANTITY OF 4 EACH REQUIRED FOR PLAIN TYPE TROLLEYS.

** TOTAL QUANTITY OF 1 EACH REQUIRED FOR 3 TON TROLLEYS.

*** SPECIFY LENGTH OF HAND CHAIN REQUIRED. STANDARD LENGTH EQUALS TWO TIMES HOIST LIFT PLUS 2'-6".

3 THRU 7½ TON MOTOR AND GEAR BOX ASSEMBLY

2 THRU 7 1/2 TON MOTOR AND GEAR BOX ASSEMBLY

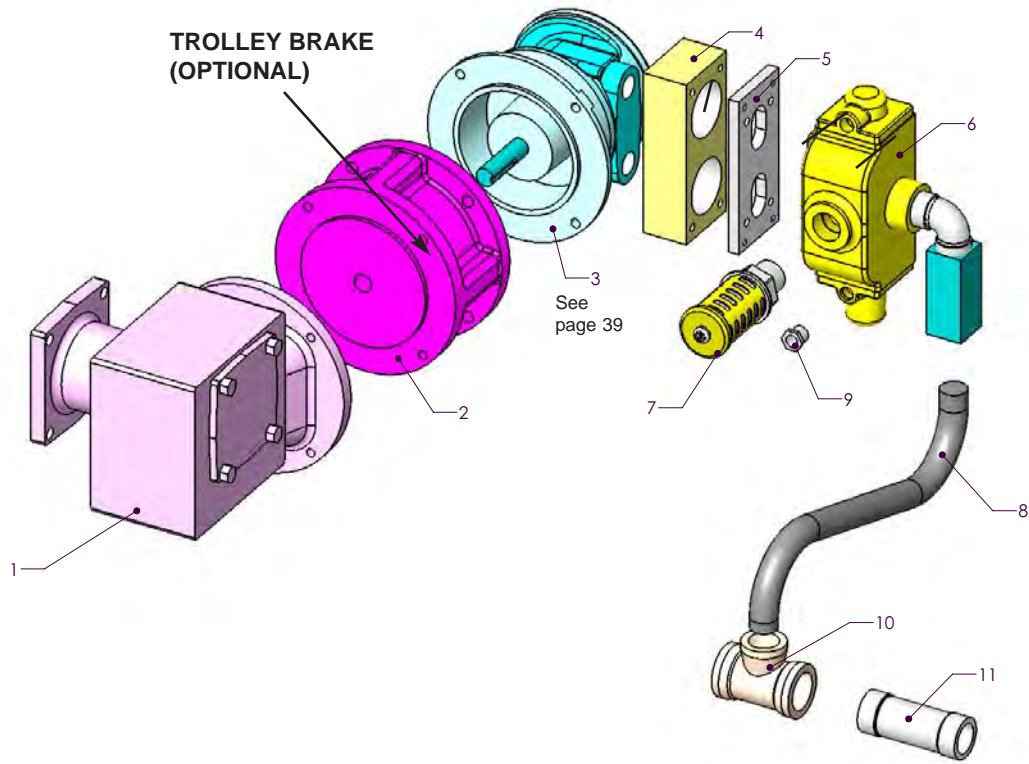

***SEE PAGE 39 FOR TROLLEY BRAKE ASSEMBLY**

Ref. No.	No. Req'd	Part Description	Part Number
1	1	Gear Box Assembly	BET-3003
2	1	Air Brake	Contact Factory
3	1	Air Motor	22721301
4	1	Mounting Plate	22925703
5	1	Sandwich Plate	22925501
6	1	Valve	22746302
7	1	Muffler	227472-1
8	1	Air Hose Assembly	53042
9	1	Hex Bushing	53039
10	1	Reducing Tee	53040
11	1	Pipe Nipple	53041
12 *	1	Gasket	11443301
13 *	1	Gasket	22746801

* Not Shown

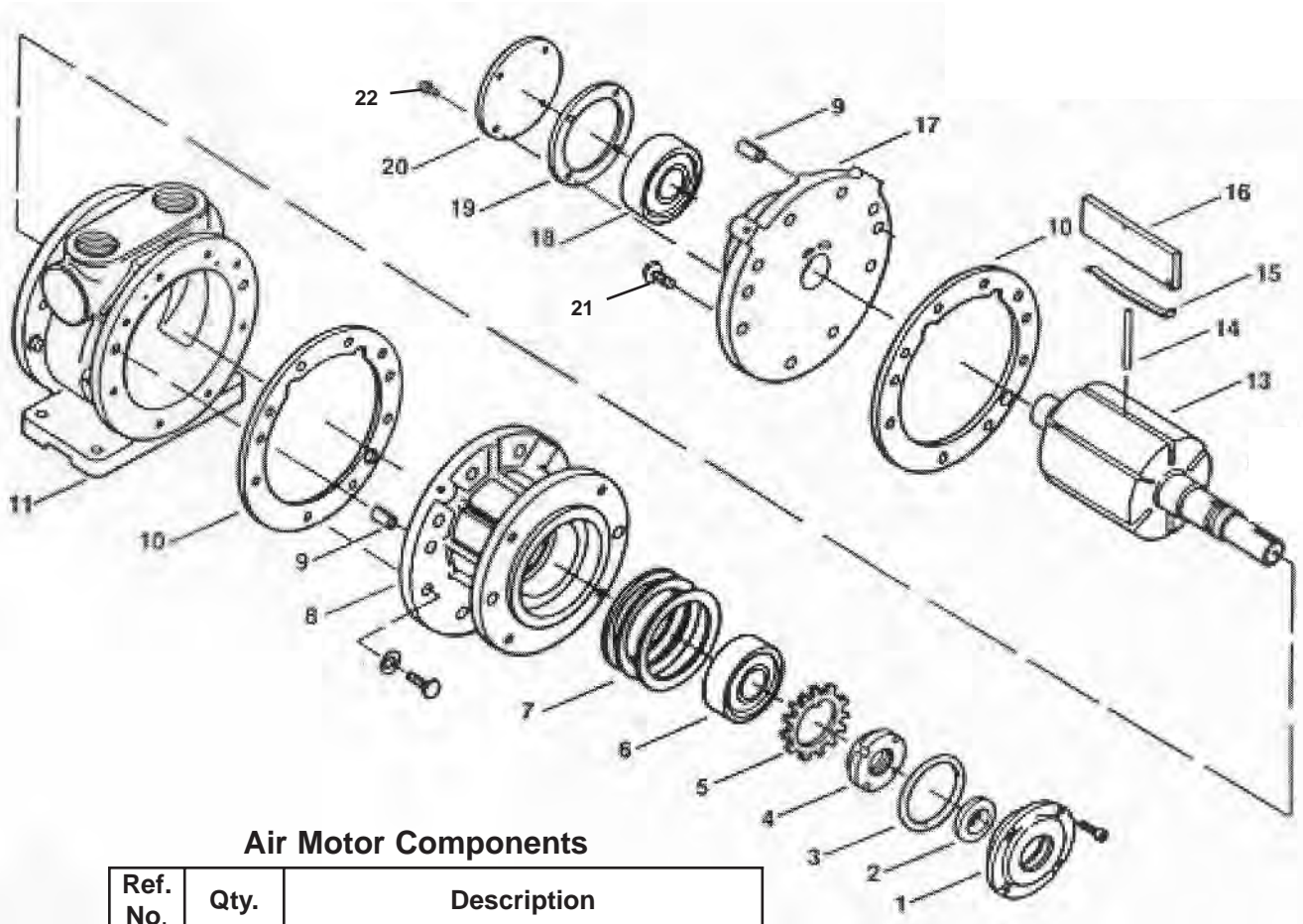

Air Motor Components

Ref. No.	Qty.	Description
1	1	Drive End Cap
2 *	1	Seal
3 *	1	O-Ring
4	1	Locknut
5 *	1	Lockwasher
6 *	1	Drive End Bearing
7	1	Spacer
8	1	Drive End Plate
9	4	Dowel Pin
10 *	2	Spacer Gasket
11	1	Body
13	3	Rotor Assembly
14 *	6	Push Pin
15 *	6	Vane Spring
16 *	1	Vane
17	1	Dead End Plate
18	1	Dead End Bearing
19	1	End Cap Gasket
20	1	Dead End Cap
21	4	Dead End Plate Bolts
22	4	Dead End Plate Cap Bolts
*	1	Service Kit 652-308 (order code 53034)

Note: Parts Identified with a star (*) are available only as part of service kit (code 53035). Remaining part numbers are not available for repair. Requires replacement with an air motor (code 53002).

Note: When ordering parts, always furnish Hoist Model and Serial Number, Motor Horsepower, Voltage, Phase, Frequency and Rated Capacity of hoist on which the parts are to be used.

For the location of the nearest Master Parts Depot, see the list located on the inside front cover.

LIMITATION OF WARRANTIES, REMEDIES AND DAMAGES

THE WARRANTY STATED BELOW IS GIVEN IN PLACE OF ALL OTHER WARRANTIES, EXPRESS OR IMPLIED, OF MERCHANTABILITY, FITNESS FOR A PARTICULAR PURPOSE, OR OTHERWISE, NO PROMISE OR AFFIRMATION OF FACT MADE BY ANY AGENT OR REPRESENTATIVE OF SELLER SHALL CONSTITUTE A WARRANTY BY SELLER OR GIVE RISE TO ANY LIABILITY OR OBLIGATION.

Seller warrants that on the date of delivery to carrier the goods are free from defects in workmanship and materials.

SELLER'S SOLE OBLIGATION IN THE EVENT OF BREACH OF WARRANTY OR CONTRACT OR FOR NEGLIGENCE OR OTHERWISE WITH RESPECT TO GOODS SOLD SHALL BE EXCLUSIVELY LIMITED TO REPAIR OR REPLACEMENT, F.O.B. SELLER'S POINT OF SHIPMENT, OF ANY PARTS WHICH SELLER DETERMINES TO HAVE BEEN DEFECTIVE or if Seller determines that such repair or replacement is not feasible, to a refund of the purchase price upon return of the goods to Seller.

Any action against Seller for breach of warranty, negligence or otherwise, must be commenced within one year after such cause of action accrues.

NO CLAIM AGAINST SELLER FOR ANY DEFECT IN THE GOODS SHALL BE VALID OR ENFORCEABLE UNLESS BUYER'S WRITTEN NOTICE THEREOF IS RECEIVED BY SELLER WITHIN ONE YEAR FROM THE DATE OF SHIPMENT.

Seller shall not be liable for any damage, injury or loss arising out of the use of the goods if, prior to such damage, injury or loss, such goods are (1) damaged or misused following Seller's

delivery to carrier; (2) not maintained, inspected, or used in compliance with applicable law and Seller's written instructions and recommendations; or (3) installed, repaired, altered or modified without compliance with such law, instructions or recommendations.

UNDER NO CIRCUMSTANCES SHALL SELLER BE LIABLE FOR INCIDENTAL OR CONSEQUENTIAL DAMAGES AS THOSE TERMS ARE DEFINED IN SECTION 2-715 OF THE UNIFORM COMMERCIAL CODE.

INDEMNIFICATION AND SAFE OPERATION

Buyer shall comply with and require its employees to comply with directions set forth in instructions and manuals furnished by Seller and shall use and require its employees to follow such instructions and manuals and to use reasonable care in the use and maintenance of the goods. Buyer shall not remove or permit anyone to remove any warning or instruction signs on the goods. In the event of personal injury or damage to property or business arising from the use of the goods, Buyer shall within 48 hours thereafter give Seller written notice of such injury or damage. Buyer shall cooperate with Seller in investigating any such injury or damage and in the defense of any claims arising therefrom.

If Buyer fails to comply with this section or if any injury or damage is caused, in whole or in part, by Buyer's failure to comply with applicable federal or state safety requirements, Buyer shall indemnify and hold Seller harmless against any claims, loss or expense for injury or damage arising from the use of the goods.

For more information contact:
American Crane & Equipment Corp.
Authorized Distributor
Tel: 877-503-2972
Fax: 484-945-0430
sales@americancrane.com
www.americancrane.com

WARNING

Alterations or modifications of equipment and use of non-factory repair parts can lead to dangerous operation and injury.

TO AVOID INJURY:

- Do not alter or modify equipment
- Do use only factory provided replacement parts.



Columbus McKinnon Corporation
140 John James Audubon Parkway
Amherst, New York 14228-1197
Phone: (800) 888-0985
Fax: (716) 689-5644



Lift-Tech International
414 West Broadway Ave.
Muskegon, Michigan 49443-0769
Phone: (231) 733-0821
Fax: (800) 742-9270



Country Club Road
P.O. Box 779
Wadesboro, NC 28170 U.S.A.
Phone 800-477-5003
Fax (800) 374-6853