



**⚠ WARNING**

**To Avoid Injury:**

- Do not exceed working load limit, load rating, or capacity.
- Do not use to lift people or loads over people.
- Read and follow all instructions.

**For more information contact:  
American Crane & Equipment Corp.  
Authorized Distributor  
Tel: 877-503-2972  
Fax: 484-945-0430  
sales@americancrane.com  
www.americancrane.com**



**SHAW-BOX**



Orders & Inquiries: Phone (800) 742.9269 • Fax (800) 742.9270 • [www.yaleshawbox.com](http://www.yaleshawbox.com)

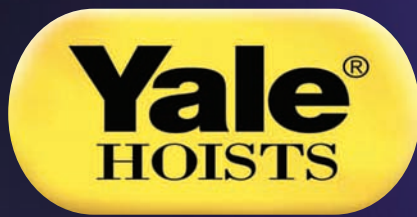

For more information contact:  
American Crane & Equipment Corp.  
Authorized Distributor  
Tel: 877-503-2972  
Fax: 484-945-0430  
sales@americancrane.com  
www.americancrane.com

## RATCHET LEVER HOISTS





## Yale® PE2 & RS2 Ratchet Lever Hoist

- 3/4 to 6 ton capacities
- Link chain models
- Light and portable
- Weatherized load brake
- Requires less handle pull to lift full load

Efficient Yale PE2 & RS2 hoists require relatively little effort to operate. (See handle pull required to lift full load in chart). All controls face the operator for convenience and safety. Free wheeling chain adjustment lever lets you play out the chain quickly and easily on unloaded units for fast hook-ups. Yale PE2 & RS2 ratchet lever hoists have been proven under the toughest of applications.

The PE2 and RS2 are designed for heavy-duty construction and industrial applications. Used to pull, lift, drag or stretch, they feature:

- Tough Aluminum alloy construction and powder coat finish
- Weatherproof for outdoor service
- Simple construction with fewer parts for ease of maintenance and lower inventories
- Hoistaloy hardened steel link type load chain for strength, long wear life and flexibility
- Weatherized Weston-type automatic braking system for positive load control
- Easy, one-hand operation and control
- Forged upper and lower hooks with latches standard
- Free wheeling for fast and easy attachment to load
- Upper and lower Latchlok hooks available for all capacities
- Optional Load Limiter protection device stops transmission of lever forces protecting against dangerous overload
- Optional anchor sling simplifies attachment to allow anchor hook to swivel in tight space applications (3/4 & 1 1/2 ton units only)
- Optional Load Sentry warns of overload condition
- Optional shorter lever for 3/4 & 1 1/2 ton units available
- Optional zinc-plated chain available
- Unlimited lift
- Lifetime warranty
- Metric rated
- Made in U.S.A.

## PE2 Link Chain Capacities: 3/4 to 6 Ton

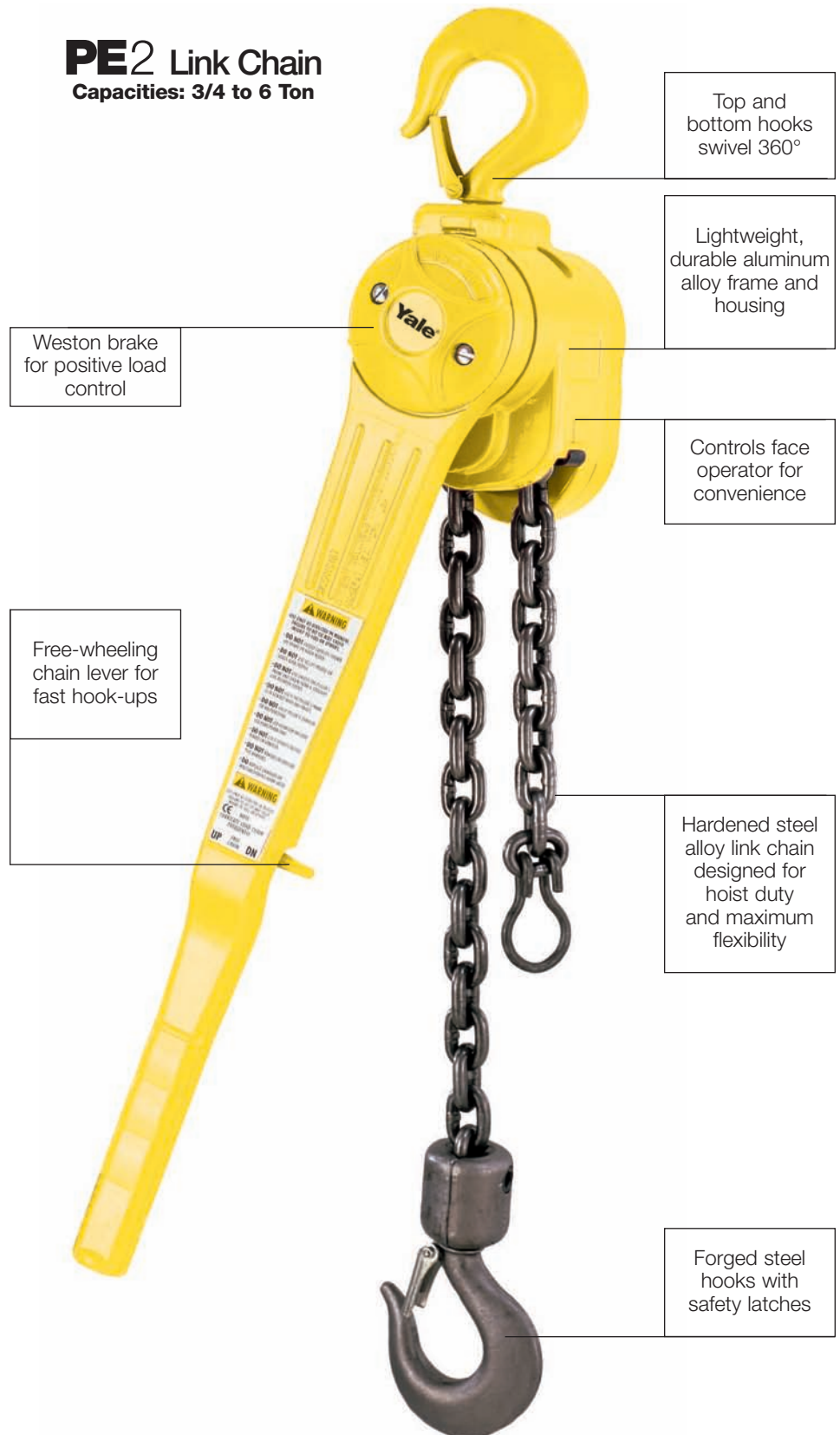

Top and bottom hooks swivel 360°

Lightweight, durable aluminum alloy frame and housing

Weston brake for positive load control

Controls face operator for convenience

Free-wheeling chain lever for fast hook-ups

Hardened steel alloy link chain designed for hoist duty and maximum flexibility

Forged steel hooks with safety latches

# RS2 Link Chain

Capacities: 3/4 to 3 Ton



## Thousands of uses throughout all types of industries

— maintenance, ship building, construction, steel fabrication, utility work, mining, petrochemical, etc.

Ideal for moving or spotting heavy machinery, pulling utility lines taut, stretching cables or fencing. Holds steel structural members in place for welding. Simplifies setting pipes, meters, etc. in manholes and trenches.

- Easy one-hand operation.
- Lever pull range is 45 to 62 pounds to lift full load.
- Handle that rotates 360°, making it easy to operate in any position and in small spaces.
- Tough yet lightweight aluminum construction and powder coat finish.
- Hoist alloy hardened steel load chain for strength, long wear life and flexibility.
- Free chaining for fast, easy attachment to load.
- Forged upper and lower hooks with latches.
- Double pawl for precise load spotting
- Simple construction with fewer parts for ease of maintenance.
- Optional Load Limiter device protects against overload.
- Lifetime warranty.
- Made in U.S.A.

## PE2 & RS2 Specifications

	Rated Capacity* (Tons)	Product Code No.	Standard Lift† (ft.)	Pull to Lift Full Load (lbs.)	Minimum Distance Between Hooks (in.)	Lever Length (in.)	Strands of Load Chain	Hook Throat Openings (in.)	Approx. Shipping Weight (lbs.)
PE2 Models	3/4	931-04108	5	58	10 3/4	21 1/4	1	1 1/32	16
	1 1/2	931-06108	5	89	14 1/4	21 1/4	1	1 1/8	26
	3	931-09108	5	95	16 15/16	21 1/4	2	1 7/32	38
	6	931-14108	5	96	21 3/8	21 1/4	4	1 3/4	73
RS2 Models	3/4	935-04101	5	45	12 1/4	12	1	1 1/32	16
	1 1/2	935-06101	5	55	14 3/4	16 3/4	1	1 1/8	27
	3	935-08101	5	62	17 5/8	16 3/4	2	1 3/16	40

†Can be supplied with lifts longer than 5 feet



## Yale PD2 Ratchet Lever Hoists

- 3/4 to 6 ton capacities
- Link chain models
- Rugged malleable iron housings and handles
- Weston type load brake and single locking pawl type
- Chain free-wheels for fast hook-ups
- Built for maximum durability

We built the Yale PD2 hoists to be extra rugged and durable. Housings are high-strength malleable cast iron to protect the gearing and brake from shock, dirt and mud. Alloy steel gears are precision machined and heat-treated for exceptional durability and long life.

The self-actuating Weston type load brake provides instantaneous brake and release action for positive, non-slip lifting and lowering. All working surfaces are plated to prevent corrosion and reduce wear.

Yale PD2 hoists incorporate a freewheeling chain feature for fast hook-ups. Simply place the selector lever in neutral (on the unloaded hoist) and turn the hand wheel to play out the desired length of chain to quickly engage the load.

The selector switch is conveniently located for one hand operation and is recessed — to protect from interference with the chain. The handle is offset to protect the operator's hand from the chain. Short radius handles permit operation in cramped quarters.

Link chain is electrically welded and provides a kink resistant flexibility. Chain guide helps prevent twisting or jamming of the chain on the load sheave on link chain models. We build every PD2 hoist with your safety and satisfaction in mind. Each one is tested and inspected before we ship it to you.

## PD2 Link Chain Capacities: 3/4 to 6 Ton

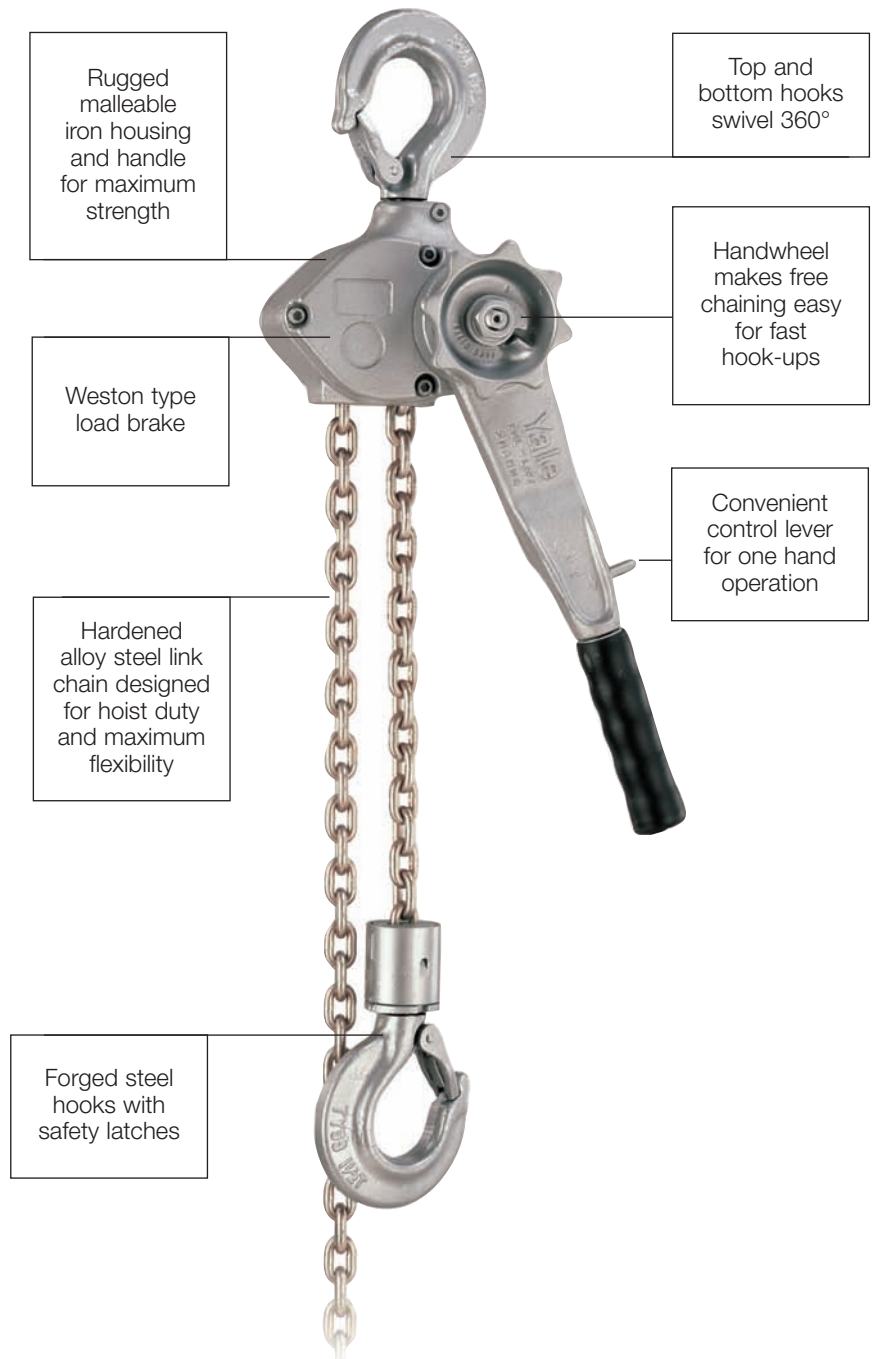

### PD2 Specifications

Product Code Number†	Rated Capacity in Tons	Standard Lift (in.)	Strands of Load Chain	Minimum Distance Between Hooks (in.)	Handle Length Inches (in.)	Average Handle Effort (lbs.)	Net Weight (lbs.)
931-04107	3/4	60	1	13	17 1/2	72	18
931-06107	1 1/2	60	1	15 1/2	17 1/2	81	29
931-09107	3	60	1	18	17 1/2	87	41
931-14107	6	60	2	21	17 1/2	87	72

†First designation is single pawl model and second "I" designation is double pawl model.

## Compact and Portable—the Yale PM Goes Where You Need It!

- 3/4 to 3 ton capacities
- Short handle design operates in cramped spaces
- Requires minimum handle pull to lift capacity load
- Self-adjusting screw-and disc type load brake compensates for brake lining wear for safe, sure stops
- Aluminum alloy housing and handle are rugged and lightweight—3/4 ton unit weighs only 13 lbs.
- Chain free-wheels on unloaded units for fast hook-ups
- Minimum 25° lever stroke permits extremely precise load placement or “micro-inching”

The Yale PM ratchet lever hoist is ideally suited for applications that demand maximum portability and ruggedness. The 3/4 ton hoist handle is a mere 12 inches long and requires only 7 lbs. of handle pull to lift a capacity load. This makes the Yale PM ratchet lever hoist an outstanding performer in cramped or awkward quarters. A 25° minimum lever stroke means that you can lift or lower a load in very small increments for precise positioning.

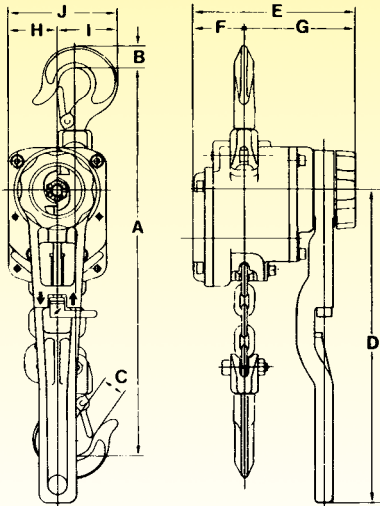

## PM Ratchet Lever Hoist

Capacities: 3/4 to 3 Ton

The Yale PM ratchet lever hoist features a screw-and-disc type load brake for safe, sure stops. This lifetime lubricated brake self-adjusts to eliminate load drift and backlash and is totally enclosed to keep foreign matter out.

High strength ductile aluminum handles and housings make Yale PM ratchet lever hoists lightweight yet durable. The hoist mechanism itself is lifetime lubricated to keep maintenance to a minimum. Alloy steel spur gears are heat treated for long life.

Forged steel top and bottom hooks swivel 360° and feature safety latches—standard. The Yale PM ratchet lever hoist incorporates a free wheeling chain feature for fast hook-ups. Simply place the lever in neutral (on the unloaded hoist) and turn the hand wheel to play out the desired length of chain to quickly engage the load.

The selector switch is conveniently located for one-hand operation and operates with a minimum of effort.



### PM Specifications

Cap. (tons)	Product Code No.	Std. Lift (feet)	Strands of Chain	Handle Pull (lbs.)	Net Wt. (lbs.)	Ship Wt. (lbs.)	Handle Length	Min. Hook to hook Distance
3/4	829-04100	5	1	37	13	16	12	12
1	829-05100	5	1	49	14	17	12	13
1 1/2	829-06100	5	1	41	21	25	12	14 1/2
3	829-09100	5	1	61	37	42	16	17 1/2

### PM Dimensions

Cap. (tons)	B	C	D	E	F	G	H	I	J
3/4	1 3/16	3/4	12	6 1/4	2	4 1/4	1 7/8	2 1/4	4 1/8
1	1	1	12	6 1/4	2	4 1/4	1 7/8	2 5/8	4 1/2
1 1/2	1 3/16	1 1/8	12	6 1/4	3	4 1/4	2 3/8	3 1/4	5 5/8
3	1 3/8	1 3/8	16	8 1/2	3 3/4	4 3/4	3	3 3/4	6 3/4

Note: All dimensions in inches unless otherwise specified.



## Yale PSB Steel Body Lever Hoists

- Compact design
- Lightweight
- Easy to free chain

The Yale PSB Steel-Body Lever Hoist has all the features of premium lever hoist but is priced for value. The innovative housing design makes the Yale PSB more compact and lightweight than ever before. Our state-of-the-art free wheel control allows you to quickly and easily take-up "slack" chain. A cushioned rubber grip is included on all models for ease of operation. The Yale PSB lever hoist is the best value in the market-place today.

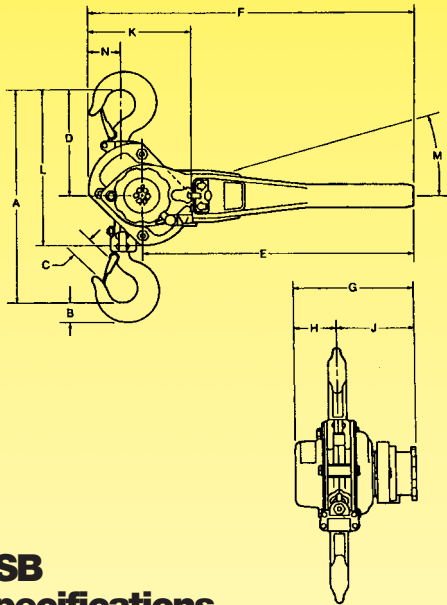

### PSB Specifications

Model Number	Capacity		Lifts (ft.)	Hook Throat Opening (in.)	Minimum Headroom (in.)	Average Pull to Lift Rated Load (lbs.)	Minimum Increment in Lifting (in.)	Net Weight for 10 Ft. Lift (lbs.)
	(Lbs.)	(Ton)						
830-04100	1500	3/4	5-10-15-20	1 5/16	11 5/8	46	0.022	15
830-06100	3000	1 1/2	5-10-15-20	1 1/4	14 31/32	55	0.022	24
830-09100	6000	3	5-10-15-20	1 1/4	16 9/16	77	0.015	38
830-14100	12000	6	5-10-15-20	1 3/4	22 7/16	84	0.0075	74

### PSB Dimensions

Model Number	Rated Load (lbs.)	A	B	C	D	E	F	G	H	J	L	M	N	No. of Load Chains
830-04100	1500	11 5/8	1 3/16	1 5/16	5 7/16	9 1/4	11 7/16	5 5/16	2 1/8	3 7/16	7 3/4	9	1 5/16	1
830-06100	3000	14 31/32	1 1/16	1 1/4	6 13/16	13 3/4	16 7/32	6 5/8	2 5/8	4	9 7/16	9	1 3/8	1
830-09100	6000	16 9/16	1 3/8	1 3/8	7 1/2	13 3/4	17 3/16	7 1/4	3 1/8	4 1/8	10 11/16	9	2 3/8	1
830-14100	12000	22 7/16	2 1/16	1 3/4	9 11/16	13 3/4	19 1/2	7 1/4	3 1/8	4 1/8	12 15/16	9	2 3/4	2

## PSB Steel Body Lever Hoist

Capacities: 3/4 to 6 Ton

- **Rated Loads**-1,500 to 12,000 lbs., 3/4 to 6 ton.
- **Lifts**- 5-10-15-20 feet.
- **Portable and Durable**- All steel construction, lightweight and impact resistant.
- **Efficient Lifting and Load Positioning**- Double reduction gearing and short handle length reduce operator's effort.
- **Positive Load Control**- Enclosed screwtype load brake stays clean and dry for positive positioning.
- **Longer Chain Life**- Through hardened load chain provides high strength and resists wear.
- **Ease of Free Chaining**- Free wheel control provides fast take-up of slack chain (position the control lever to neutral). Lifetime warranty on free chain knob.
- **Safety Latches**- 360 degree swiveling hooks are equipped with latches for positive load engagement.



