

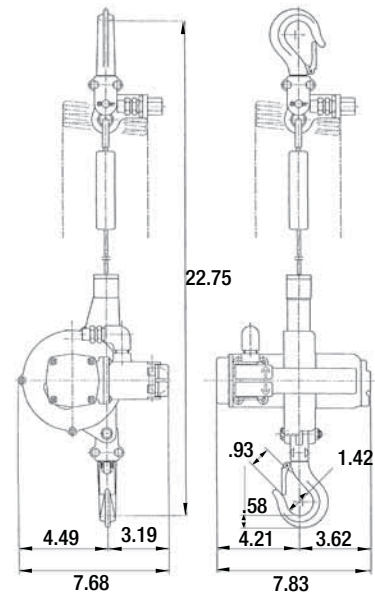

- Capacity: Rated loads 300 lbs./140 kg.
- Efficient rotary vane motor provides high uniform torque for quick response and smooth, quiet operation.
- Handle-mounted pendant control for one-handed operation and load positioning.
- Precise and infinite speed control for accurate load spotting.
- Self-winding lifting cable stores conveniently inside unit.
- Swivel top and bottom hooks with safety latches standard, for portability and quick installation.
- Secures load and eliminates drift when pendant is released.
- A 3/8" NPT air filter-regulator-lubricator is needed for effective operation. Spark resistant features are not available.
- Lifetime Warranty
- Ideal Applications
  - Assembly Line
  - Machine Shops
  - Cleaning and/or Dipping Operations
  - Manufacturing Plants
  - Power Generating Stations
  - Shipping Departments
  - Chemical Facilities
  - Fabricating Shops
  - Repetitive Lifting Applications
  - Auto/Truck Repair
  - Handling Fixtures and Dies

For more information contact:  
**American Crane & Equipment Corp.**  
 Authorized Distributor  
 Tel: 877-503-2972  
 Fax: 484-945-0430  
 sales@americancrane.com  
 www.americancrane.com



### Specifications & Dimensions

Capacity	Model #	Standard Lift	Lift Speed w/ load		Lift Speed w/o load		Air Consump.	Headroom	Housing Dimensions			Max Air Pressure	Net Weight
			Up	Down	Up	Down			D	W	L		
lbs.		ft.	FPM				CFM	in	in.			psi	lbs.
300	TMM-140	6' 6"	36	59	49	39	21.2	22-3/4	7-2/3	7-7/8	23-3/4	70-95	18.7